

## TargetLynx Matrix Calculator: A Tool for Robust Analytical Methods Development

Marian Twohig, Joanne Mather, and Alex Hooper  
Waters Corporation, Milford, MA, U.S.

### APPLICATION BENEFITS

The TargetLynx Matrix Calculator provides a convenient way to evaluate the matrix factor during the development of bioanalytical methods. This is a helpful technique to identify methods that may be susceptible to matrix effects that could potentially affect long-term method robustness.

### WATERS SOLUTIONS

ACQUITY UPLC®

Xevo™ TQ MS

MassLynx™ Software

TargetLynx™ Application Manager

### KEY WORDS

RADAR™ Scanning Technology,  
matrix effects

### INTRODUCTION

In quantitative bioanalysis, the analytical technique of choice is LC/MS/MS due to the high sensitivity and selectivity that it affords. Quantitative bioanalytical methods development by LC/MS/MS is complicated by the interference of the matrix, as the analyte response can differ significantly within a matrix.<sup>1</sup> It is necessary to develop robust analytical methods to ensure the long-term integrity of the results.

Matrix effects, resulting from coeluting matrix components that compete for charge in the ionization process, manifest themselves as suppression or enhancement of the analyte signal. Matrix effects are caused by numerous factors:

- Phospholipids
- Subject differences
- Impurities
- Coeluting metabolites
- Degradation products

All of the above can cause significant errors in the accuracy and precision of bioanalytical assays.<sup>2</sup>

As part of the method validation process, it is necessary to measure the ion suppression due to the matrix and calculate a matrix factor. This is often a time-consuming process – often requiring the transfer of the MS data to external software programs. This application note describes the use of a simple algorithm to estimate the matrix factor automatically.

### How does the TargetLynx Matrix Calculator work?

Using the TargetLynx Application Manager, three sample types are defined in the sample list:

- **Analyte** – One compound of interest (and its internal standard if present) is injected onto the column to determine retention time
- **Solvent** – A solvent blank is injected through the column with a post-column infusion of the analyte and the internal standard
- **Matrix blank** – An aliquot of the blank-extracted matrix is injected through the column with a post-column infusion of the analyte and its internal standard

The solvent and matrix blank experiments (Figure 1) are run multiple times and the coefficient of variation (CV) is calculated when the data is processed.

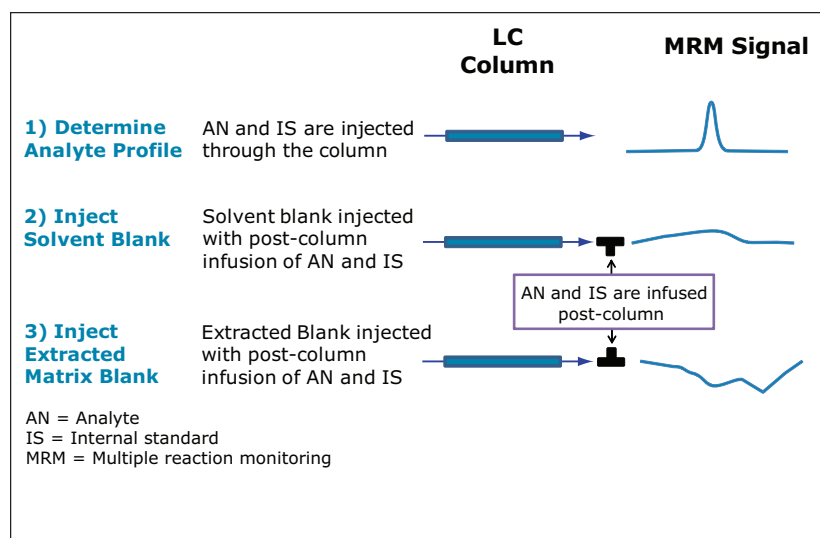

Figure 1. Illustration of the three matrix factor experiments.

Figure 2 illustrates the workflow for calculating the matrix factor. A sample matrix factor calculation is shown in Figure 4. (MF= Matrix Factor, A = Area). This formula is incorporated into the matrix calculator, and the MF and IS normalized MF are calculated automatically when the data from the three LC/MRM experiments are processed.

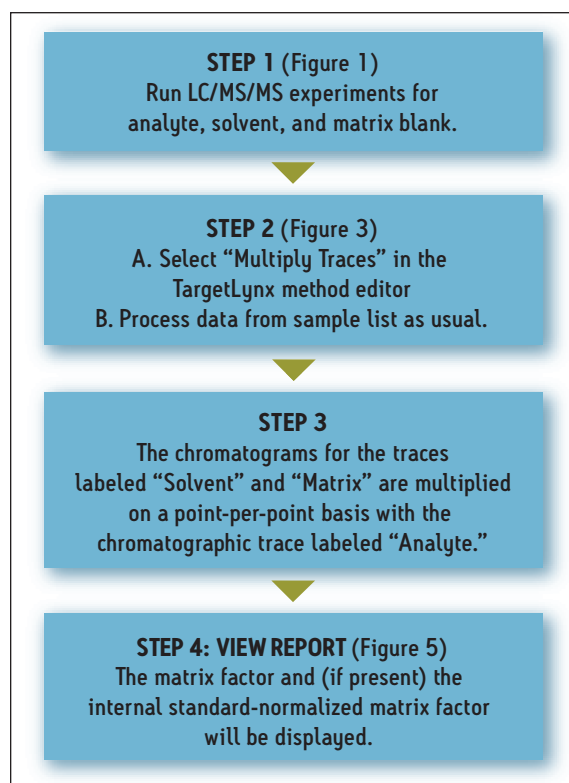

Figure 2. Matrix factor calculation workflow.

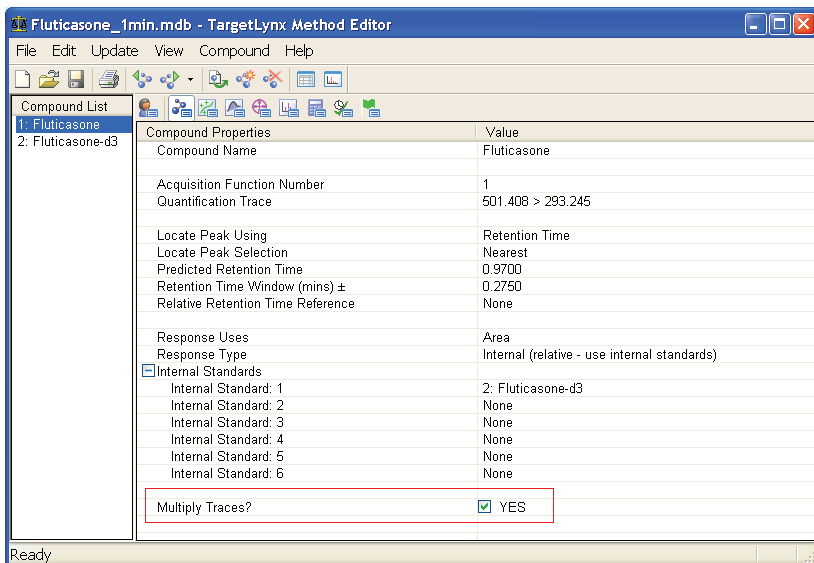

Figure 3. TargetLynx method editor.

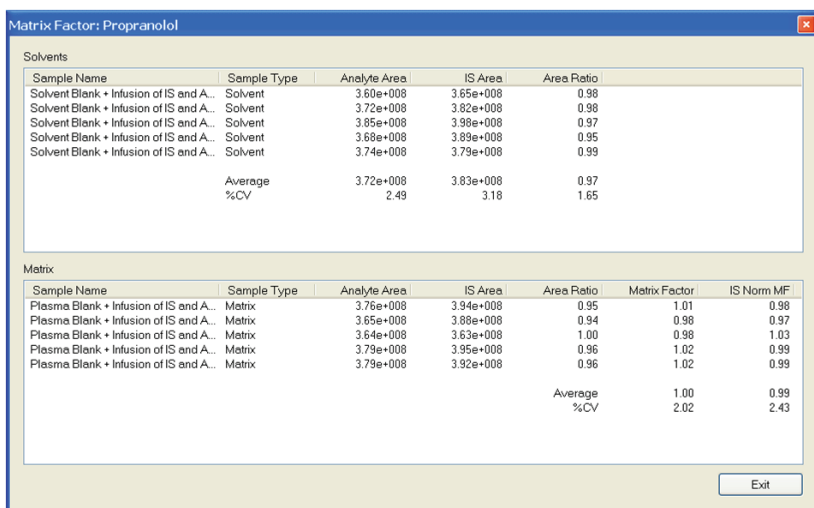

Figure 4. Sample matrix factor report.

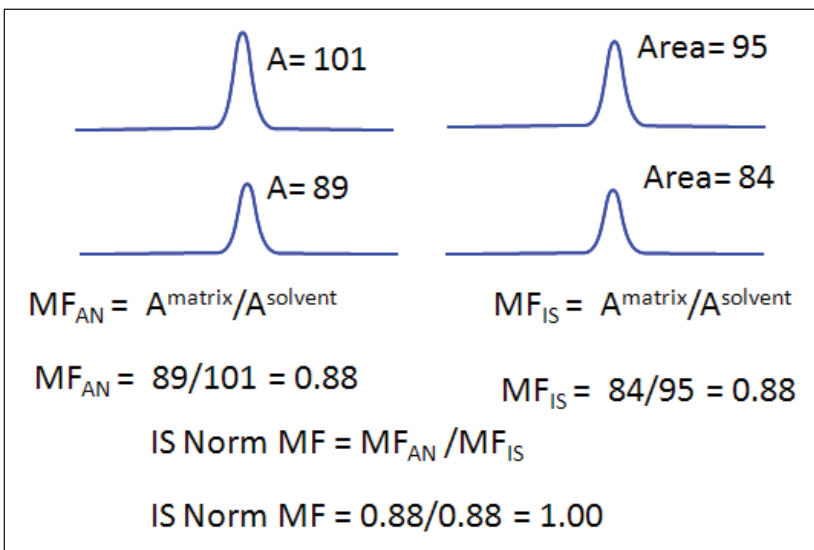

Figure 5. Sample matrix factor calculation.

## EXPERIMENTAL

## LC conditions

Solvent delivery:	Waters® ACQUITY UPLC Binary Solvent Manager
Sample delivery:	Waters ACQUITY UPLC Sample Manager
Column:	ACQUITY UPLC BEH C <sub>18</sub> 1.7 μm, 2.1 x 50 mm
Column temp.:	45 °C
Sample temp.:	4 °C
Injection vol.:	5 μL
Flow rate:	600 μL/min
Mobile phase A:	0.1% ammonium hydroxide in water
Mobile phase B:	Methanol
Gradient 1:	5% to 95% B in 0.70 min
Gradient 2:	5% to 95% B in 2.00 min

## MS conditions

MS system:	Waters Xevo™ TQ MS
Ionization mode:	ESI positive
Capillary voltage (ESI):	1.0 kV
Compound:	Fluticasone propionate 501 > 293
Cone voltage:	18 V
Collision energy:	20 eV
Compound:	Fluticasone propionate–D3 504 > 293
Cone voltage:	18 V
Collision energy:	20 eV
Compound:	Phospholipids 184 > 184
Cone voltage:	75 V
Collision:	4 eV
RADAR:	Qualitative Scan100 to 900 amu
Scan speed:	10,000 amu/s
Source temp.:	150 °C
Desolvation temp.:	450 °C
Desolvation gas:	1000 L/hr

## Sample extraction

Plasma proteins were precipitated using acetonitrile (2:1 ratio).

## DISCUSSION

## Using the Matrix Calculator

Fluticasone propionate was analyzed in plasma. Acetonitrile (2:1) was used to precipitate plasma proteins. Two sets of experimental conditions were used, a short gradient of 0.70 min and a longer gradient of 2.00 min. The elution profile of fluticasone was determined for each chromatographic method. Fluticasone and its D3 internal standard were infused into the LC stream post-column. A solvent blank was injected ( $n=5$ ) followed by blank-extracted plasma ( $n=5$ ). TargetLynx was used to process the data and to automatically calculate the matrix factor for both sets of experimental conditions.

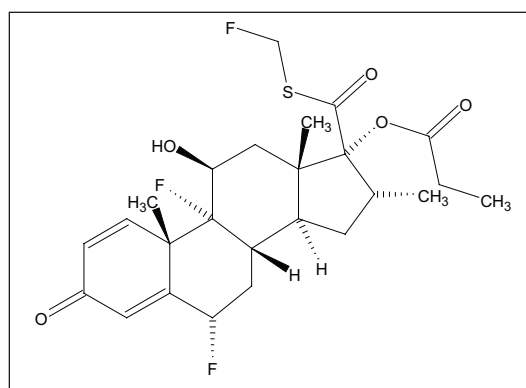

Figure 6. Structure of Fluticasone propionate.

### Gradient method 1: 5% to 95% MeOH in 0.70 min

It can be seen in Figure 7 from the LC/MS/MS chromatogram that the fluticasone has a retention time of 0.97 min. The analyte chromatogram is superimposed on the plasma-blank injection where there is a post-column infusion of the analyte and the internal standard. The fluticasone elutes in a region of the chromatogram where there appears to be a suppression event occurring.

The calculated matrix factor of 0.34 shown in Figure 8 reflects this significant matrix effect. The deuterated internal standard ensures that the results are normalized to 0.99. This matrix factor is not acceptable for a bioanalytical assay. We can see from the infusion chromatogram that the peak of interest elutes at the same retention time as significant matrix material.

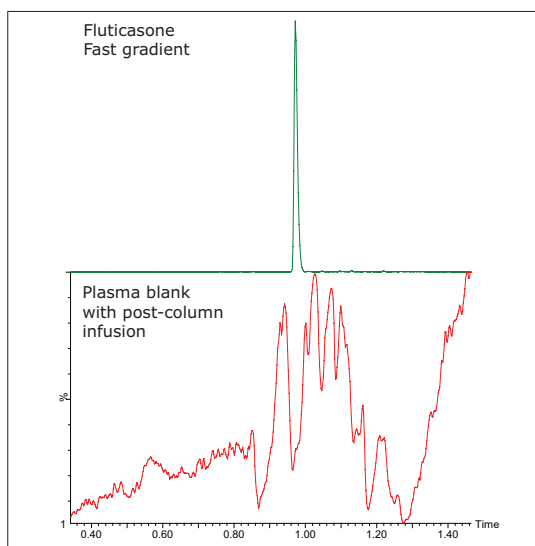

Figure 7. LC/MS/MS chromatograms from a fast gradient. Analyte peak is superimposed on the plasma blank chromatogram where there is a post-column infusion of fluticasone and its D3 internal standard.

Matrix Factor: Fluticasone

Solvents				
Sample Name	Sample Type	Analyte Area	IS Area	Area Ratio
Solvent Blank + Infusion of IS and A...	Solvent	5.41e+008	3.89e+008	1.39
Solvent Blank + Infusion of IS and A...	Solvent	5.64e+008	3.94e+008	1.43
Solvent Blank + Infusion of IS and A...	Solvent	5.26e+008	3.82e+008	1.38
Solvent Blank + Infusion of IS and A...	Solvent	5.47e+008	3.87e+008	1.41
Solvent Blank + Infusion of IS and A...	Solvent	5.39e+008	3.82e+008	1.41
	Average	5.43e+008	3.87e+008	1.41
	%CV	2.58	1.27	1.57

Matrix						
Sample Name	Sample Type	Analyte Area	IS Area	Area Ratio	Matrix Factor	IS Norm MF
Plasma Blank + Infusion of IS and A...	Matrix	1.93e+008	1.45e+008	1.33	0.36	0.95
Plasma Blank + Infusion of IS and A...	Matrix	1.82e+008	1.31e+008	1.39	0.34	0.99
Plasma Blank + Infusion of IS and A...	Matrix	1.85e+008	1.29e+008	1.43	0.34	1.02
Plasma Blank + Infusion of IS and A...	Matrix	1.75e+008	1.26e+008	1.39	0.32	0.99
Plasma Blank + Infusion of IS and A...	Matrix	1.82e+008	1.30e+008	1.40	0.34	1.00
	Average				0.34	0.99
	%CV				3.50	2.68

Exit

Figure 8. Matrix factor report for gradient method 1.

### Gradient method 2: 5% to 95% MeOH in 2.00 min

When a 2.00-min gradient was used, the retention time of the fluticasone peak was 1.95 min (Figure 9). The matrix factor report shown in Figure 10 was calculated to be 0.91, which normalizes to 1.01, due to the presence of the internal standard. It can be noted that the proximity of the analyte peak to the region of suppression has changed to a region of less coelution.

The Xevo TQ MS employs RADAR Scanning Technology to acquire both MS and MS/MS data simultaneously (formerly referred to as dual scan-MRM). This technology provides a convenient way to monitor the background while collecting MRM data for quantitation.<sup>3</sup>

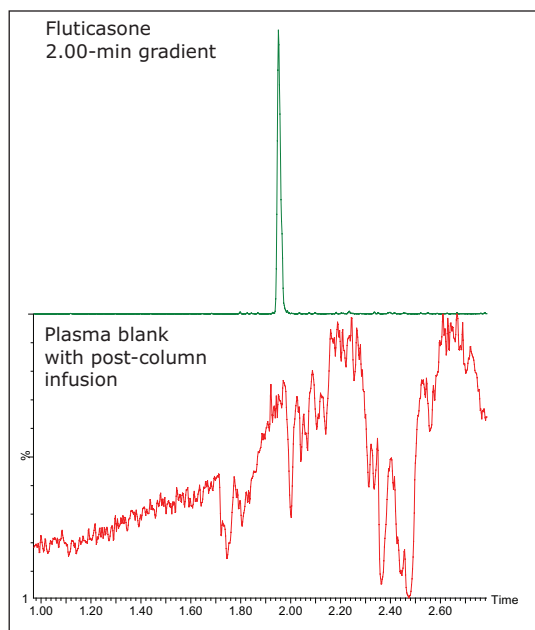

Figure 9. LC/MS/MS chromatograms from a 2.00-min gradient for the analyte peak superimposed on the plasma-blank chromatogram, where there is a post-column infusion of fluticasone and its D3 internal standard.

Matrix Factor: Fluticasone

Solvents				
Sample Name	Sample Type	Analyte Area	IS Area	Area Ratio
Solvent Blank + Infusion of IS and A...	Solvent	2.98e+008	2.10e+008	1.42
Solvent Blank + Infusion of IS and A...	Solvent	3.06e+008	2.16e+008	1.42
Solvent Blank + Infusion of IS and A...	Solvent	3.13e+008	2.19e+008	1.43
Solvent Blank + Infusion of IS and A...	Solvent	3.08e+008	2.14e+008	1.44
Solvent Blank + Infusion of IS and A...	Solvent	3.00e+008	2.09e+008	1.43
	Average	3.05e+008	2.13e+008	1.43
	%CV	2.09	1.94	0.54

Matrix						
Sample Name	Sample Type	Analyte Area	IS Area	Area Ratio	Matrix Factor	IS Norm MF
Plasma Blank + Infusion of IS and A...	Matrix	2.69e+008	1.89e+008	1.43	0.88	1.00
Plasma Blank + Infusion of IS and A...	Matrix	2.74e+008	1.91e+008	1.43	0.90	1.00
Plasma Blank + Infusion of IS and A...	Matrix	2.65e+008	1.85e+008	1.44	0.87	1.00
Plasma Blank + Infusion of IS and A...	Matrix	2.74e+008	1.88e+008	1.46	0.90	1.02
Plasma Blank + Infusion of IS and A...	Matrix	3.00e+008	2.03e+008	1.48	0.98	1.04
	Average				0.91	1.01
	%CV				4.96	1.58

Exit

Figure 10. Matrix factor report for gradient method 2.



Depending on the chromatographic conditions, analytes can coelute with endogenous matrix components and/or metabolites, leading to potential matrix effects and possible reduced-assay robustness. When MRM is used exclusively, only the specified precursor > product ions are seen. Qualitative RADAR scans show all masses that are defined in the MS method scan.

In Figure 11, the proximity of the analyte peak to the phospholipids can readily be visualized. It has been reported that the concentration of the phospholipids at the retention time of the analyte can greatly influence the existence of matrix effects.

It can be seen from the RADAR qualitative scan of the plasma blank in Figure 12 that there is more chromatographic resolution between the matrix peaks and the analyte when it elutes at 1.95 min. This is supported by the data from the matrix calculator.

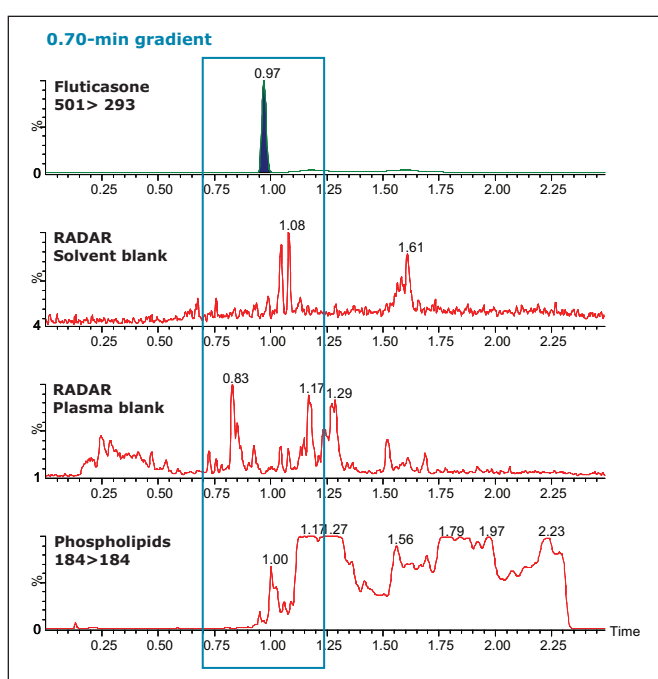

Figure 11. LC/MS/MS chromatograms from a 0.70-min gradient for (a) fluticasone and (d) lipid fraction; RADAR scan of the solvent and plasma matrices.

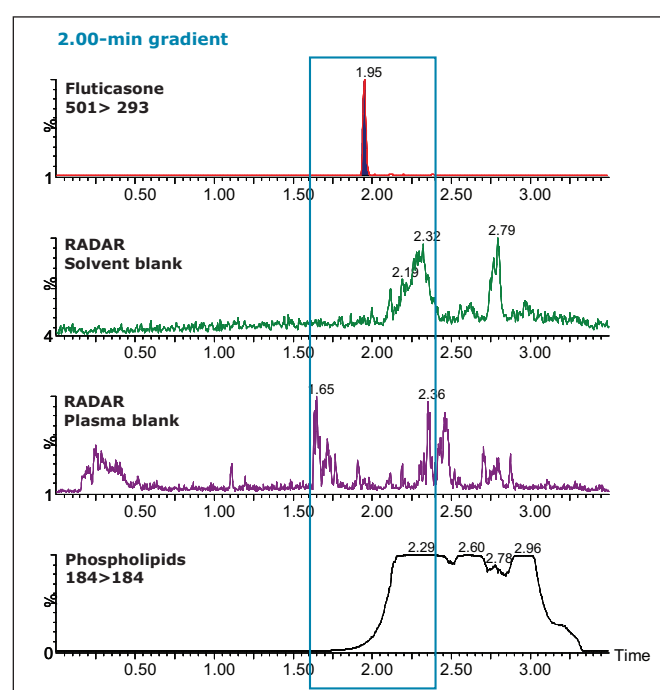

Figure 12. LC/MS/MS chromatograms from a 2.00-min gradient for (a) fluticasone and (d) lipid fraction; RADAR scan of the solvent and plasma matrices.

## CONCLUSIONS

- The TargetLynx Matrix Calculator is a convenient way of evaluating the matrix factor during the method-development process. This can help to identify methods that might be susceptible to matrix effects that could potentially affect long-term method robustness.
- The Xevo TQ MS allows RADAR scanning to be used to monitor the background and detect non-targeted compounds while also collecting targeted MRM data for quantitation.<sup>3</sup>
- RADAR qualitative scanning used in conjunction with the TargetLynx Matrix Calculator is a useful tool for the rapid development of robust bioanalytical methods.
- Different plasma lots can easily be screened to calculate the matrix factor in the method validation stage.

## References

1. Tang P, Tang L. Anal. Chem. 1993; 65: 972A–986A.
2. Chambers E, Diehl, DM, Lu Z, Mazzeo JR. Journal of Chromatography B. 2007; 852: 22–34.
3. Dual Scan MRM Mode: A Powerful Tool for Bioanalytical LC/MS/MS Method Development. Waters Application Note. 2009; 720003039en.

# Waters

THE SCIENCE OF WHAT'S POSSIBLE.™

Waters and ACQUITY UPLC are registered trademarks of Waters Corporation. Xevo, RADAR, and The Science of What's Possible are trademarks of Waters Corporation. All other trademarks are the property of their respective owners.

©2010 Waters Corporation. Produced in the U.S.A.  
July 2010 720003580EN AG-PDF

**Waters Corporation**  
34 Maple Street  
Milford, MA 01757 U.S.A.  
T: 1 508 478 2000  
F: 1 508 872 1990  
[www.waters.com](http://www.waters.com)

