

Analysis of Serum Cortisol, Androstenedione, and 17-hydroxyprogesterone Using 2D UPLC-MS/MS for Clinical Research

Robert Wardle and Lisa Calton
 Waters Corporation, Wilmslow, Cheshire, UK

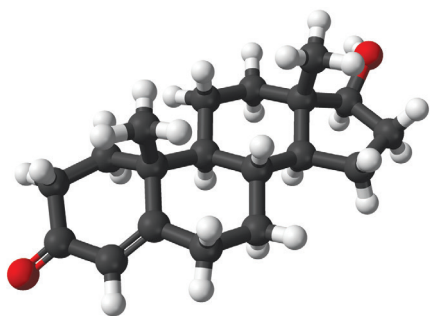

GOAL

To successfully develop a 2D UPLC-MS/MS system configuration for the analysis of serum cortisol, androstenedione, and 17-hydroxyprogesterone.

BACKGROUND

Sample preparation for clinical research applications of LC-MS/MS is required to reduce interferences from biological matrices, to reach the analytical sensitivity requirements and to ensure a compatible diluent is injected onto the system. Since sample preparation can be time consuming and prone to error, there is interest in simplifying the sample preparation workflow for LC-MS/MS applications.

Here we describe an approach using the Waters® ACQUITY UPLC® I-Class System with 2D technology to perform online sample clean-up for the analysis of steroid hormones using a Xevo® TQD, following a simple protein precipitation extraction.

This system configuration is flexible, allowing the user to configure the system flow path in a number of ways that enable its operation in different modes; trapping and back transfer, heart-cutting, parallel column regeneration,

Waters 2D technology provides flexibility of analysis without making changes to the system.

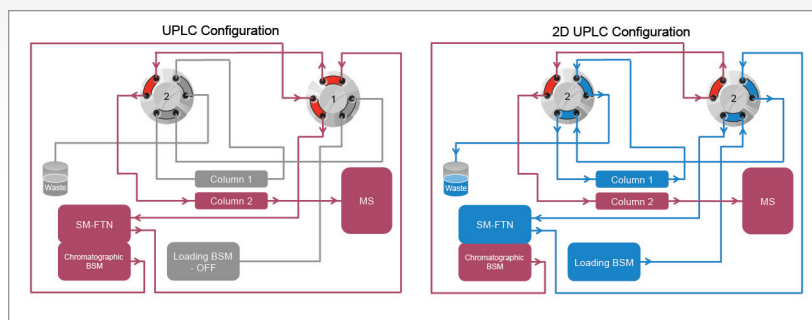

Figure 1. ACQUITY UPLC I-Class System with 2D technology flow path configuration.

at-column dilution as well as UPLC® mode. Therefore, the system can be tailored to meet specific method requirements and maximize laboratory productivity. The configuration used in this technical brief utilizes a 2D UPLC trapping and back flush mode with the option to switch to direct UPLC analysis without any changes to the system.

This configuration allows for large injection volumes to maximize peak area response, where the analytes of interest are focused on Column 1 using the mobile phase gradient from the Loading BSM. The analytes are back-flushed off Column 1 onto Column 2 for chromatographic separation. While the chromatographic separation is taking place on Column 2, Column 1 is washed and re-equilibrated using the Loading BSM (Flow path shown in Figure 1).

THE SOLUTION

In this technology brief, a method for the analysis of serum cortisol, androstenedione, and 17-hydroxyprogesterone was successfully developed on an ACQUITY UPLC I-Class with 2D Technology with a Xevo TQD. A simple protein precipitation followed by separation using an ACQUITY UPLC BEH C₁₈ SB VanGuard™ Pre-column in the first dimension and an ACQUITY UPLC HSS T3 Column in the second dimension was used to selectively clean the serum sample to provide optimum analytical performance.

Analyte	Calibration curve range (nmol/L)	Conversion factor (nmol/L to ng/mL)
Cortisol	1.7 – 1380	0.362
Androstenedione	0.17 – 349	0.286
17OHP	0.38 – 757	0.330

Table 1. Calibration curve ranges for each analyte.

Analyte	Precursor ion (m/z)	Product ion (m/z)	Cone voltage (V)	Collision energy (eV)
Androstenedione (Quan)	287.2	97.0	36	22
Androstenedione (Qual)	287.2	109.0	36	22
[¹³ C ₃]-Androstenedione	290.2	100.0	36	22
17OHP (Quan)	331.2	97.0	40	25
17OHP (Qual)	331.2	109.0	40	25
[¹³ C ₃]-17OHP	334.2	100.0	40	25
Cortisol (Quan)	363.2	97.0	32	30
Cortisol (Qual)	363.2	121.0	32	25
[¹³ C ₃]-Cortisol	366.2	100.0	32	30

Table 2. MRM parameters for androstenedione, 17-hydroxyprogesterone, cortisol, and their respective internal standards.

Compound	Low			Mid			High		
	Conc. (nmol/L)	Total (%CV)	Repeatability (%CV)	Conc. (nmol/L)	Total (%CV)	Repeatability (%CV)	Conc. (nmol/L)	Total (%CV)	Repeatability (%CV)
Cortisol	6.8	4.7	4.7	68.1	2.5	2.5	610	2.5	2.4
Androstenedione	1.7	2.9	2.9	16.7	2.6	2.4	154	2.5	2.5
17OHP	3.7	3.1	3.1	37.9	3.3	3.1	337	2.7	2.7

Table 3. Total precision and repeatability assessment for the analysis of cortisol, androstenedione, and 17-hydroxyprogesterone in serum.

SAMPLE PREPARATION AND 2D UPLC-MS/MS ANALYSIS

Calibrators were prepared in stripped serum over the concentration range specified in Table 1, with conversion factors provided. Calibrators, QCs and serum samples were diluted with internal standard, zinc sulfate_(aq) solution and methanol, followed by centrifugation at ~25,000 g for five minutes. 100 µL of each extracted sample was injected onto the 2D UPLC system. Loading onto the first column was performed by utilizing a water/methanol/formic acid gradient on an ACQUITY UPLC BEH C₁₈ SB VanGuard Pre-column and chromatographic separation was achieved using a water/methanol/ammonium acetate/formic acid gradient on an ACQUITY UPLC HSS T3 Column. The analytes were detected and quantified using a Xevo TQD, using electrospray in positive ionization mode and the MRM parameters are described in Table 2.

RESULTS

Using 2D UPLC-MS/MS, calibration curve correlation coefficients (r²) for cortisol, androstenedione, and 17-hydroxyprogesterone were >0.99 across the concentration ranges specified in Table 1.

A typical chromatogram obtained from a low level calibrator can be seen in Figure 3.

Total precision and repeatability of the method was assessed by extracting and quantifying serum samples in five replicates at low, mid, and high concentrations across five days (n=25). All results were ≤4.7% CV as shown in Table 3.

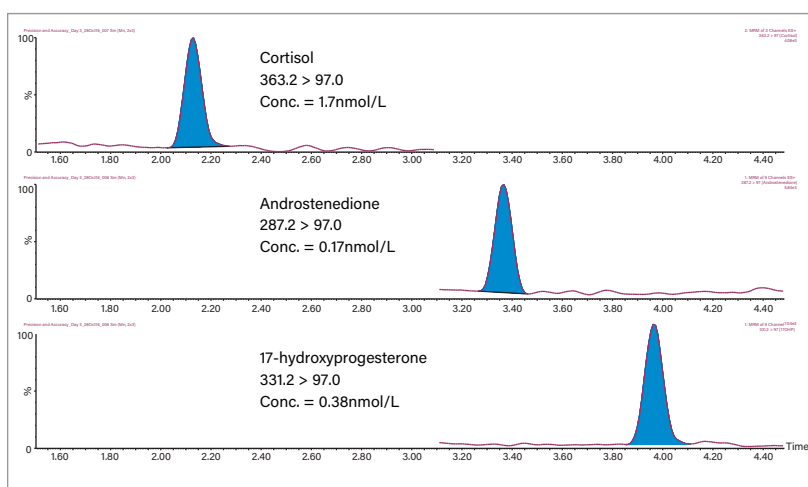

Figure 3. Typical chromatogram of the low level calibrator for cortisol, androstenedione, and 17-hydroxyprogesterone.

Method performance was assessed by extracting and quantifying external quality assurance samples from the UK National External Quality Assessment Service (UK NEQAS) for cortisol, androstenedione, and 17-hydroxyprogesterone over six days. Good agreement was observed when comparing the 2D UPLC-MS/MS method to the UK NEQAS LC-MS all laboratory trimmed mean (ALTM) values, having Deming regression equations of $y=1.03x-2.66$ for cortisol, $y=1.06x-0.04$ for androstenedione and $y=0.99x-0.10$ for 17-hydroxyprogesterone (Figure 4).

Analytical sensitivity was assessed by extracting and quantifying serum samples using 10 replicates from low to high concentrations across three days ($n=30$). Signal-to-noise (ptp) of $>10:1$ and %CV's of $<20\%$ were obtained at 1.9nmol/L for cortisol, 0.16nmol/L for androstenedione and 0.37nmol/L for 17-hydroxyprogesterone.

SUMMARY

A 2D UPLC-MS/MS method has been developed for the quantitative measurement of steroid hormones for clinical research. The system used is flexible and allows for switching to direct UPLC-MS/MS mode of operation with no system changes required.

The benefits of this method include:

- Simplified preparation of serum using 2D UPLC analysis; only a simple and fast manual protein precipitation extraction is required.

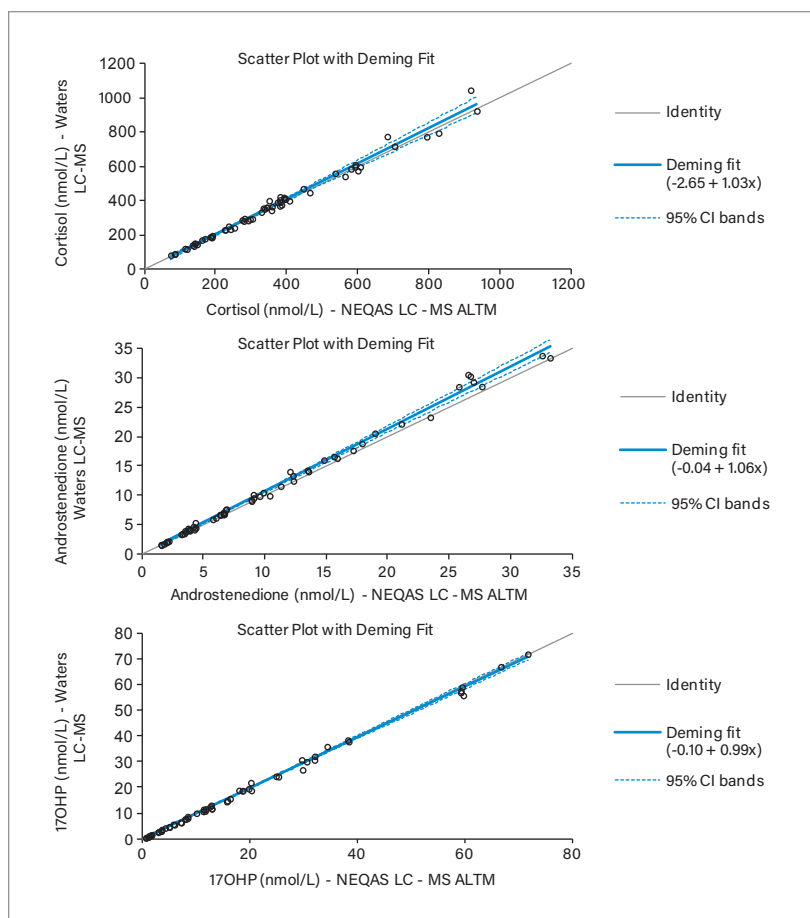

Figure 4. Scatter plot with Deming fit for cortisol, androstenedione, and 17-hydroxyprogesterone.

- Excellent precision performance ($\leq 4.7\%$ CV) for all analytes across all concentration levels tested.
- Analytically sensitive analysis of cortisol (1.9 nmol/L), androstenedione (0.16 nmol/L), and 17-hydroxyprogesterone (0.37 nmol/L) using a Xevo TQD from just 100 μ L of serum.

For Research Use Only. Not for use in diagnostic procedures.

Waters

THE SCIENCE OF WHAT'S POSSIBLE.®

Waters, The Science of What's Possible, ACQUITY UPLC, Xevo, and UPLC are registered trademarks of Waters Corporation. Vanguard is a trademark of Waters Corporation. All other trademarks are the property of their respective owners.