

916 Ti-Touch



Tutorial
8.916.8002EN



Metrohm AG

CH-9100 Herisau

Switzerland

Phone +41 71 353 85 85

Fax +41 71 353 89 01

info@metrohm.com

www.metrohm.com

916 Ti-Touch

Tutorial

Technical Communication
Metrohm AG
CH-9100 Herisau
techcom@metrohm.com

This documentation is protected by copyright. All rights reserved.

This documentation has been prepared with great care. However, errors can never be entirely ruled out. Please send comments regarding possible errors to the address above.

Table of contents

1	Introduction	1
1.1	Structure of the tutorial	1
1.2	Additional information	1
1.3	Symbols and conventions	1
2	Installation	3
2.1	Setting up and connecting the instrument	3
2.2	Mounting the electrode holder and inserting the propeller stirrer (depending on the product version)	10
2.3	Inserting an electrode and buret tip	11
3	Switching the instrument on and off and selecting the dialog language	14
3.1	Switching the instrument on and off	14
3.2	Selecting the dialog language	16
4	Fundamentals of operation	17
4.1	Touch-sensitive screen	17
4.2	Display elements and controls	17
4.3	Status display	19
4.4	Entering text and numbers	20
5	Setup and configuration	22
5.1	Preparing instruments and material	22
5.2	Configuring a new titrant	22
5.3	Configuring a new sensor	25
5.4	Configuring a printer	27
6	Carrying out simple titrations	29
6.1	Creating a titration method	29
6.2	Entering user name and sample data	38
6.3	Carrying out the determination	40
6.3.1	Preparing the titration	40
6.3.2	Carrying out the titration	41
6.3.3	Displaying the results	42
6.3.4	Recalculating the determination	43
6.3.5	Printing a report manually	45



7	Performing titration with supplementary functions	47
7.1	Statistics function	47
7.2	Saving the determination and the PC/LIMS report	48
7.3	Modifying the titration parameters	51
7.4	Creating a sample table	53
7.5	Carrying out titrations using the sample table	55
8	Setting up the user administration	56
8.1	Creating a user list	56
8.2	Automatic login with USB flash drive	58
8.3	Login with password	60

1 Introduction

1.1 Structure of the tutorial



This tutorial describes the installation and the first steps with the 916 Ti-Touch. You will be guided step by step through the most important dialog pages by using a simple pH titration as an example. In addition, you will find information regarding titrations with extended functions and for user administration.

1.2 Additional information

Detailed information concerning the 916 Ti-Touch can be found in the manual.

1.3 Symbols and conventions

The following symbols and formatting may appear in this documentation:

(5-12)	Cross-reference to figure legend
	The first number refers to the figure number, the second to the instrument part in the figure.
1	Instruction step
	Carry out these steps in the sequence shown.
Method	Dialog text, parameter in the software
File ▶ New	Menu or menu item
[Next]	Button or key
	WARNING
	This symbol draws attention to a possible life-threatening hazard or risk of injury.
	WARNING
	This symbol draws attention to a possible hazard due to electrical current.
	WARNING
	This symbol draws attention to a possible hazard due to heat or hot instrument parts.



WARNING

This symbol draws attention to a possible biological hazard.



CAUTION

This symbol draws attention to possible damage to instruments or instrument parts.



NOTE

This symbol highlights additional information and tips.

2 Installation

2.1 Setting up and connecting the instrument

916 Ti-Touch

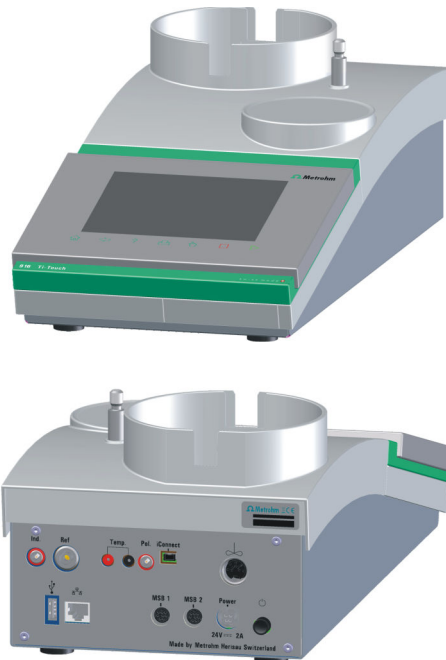
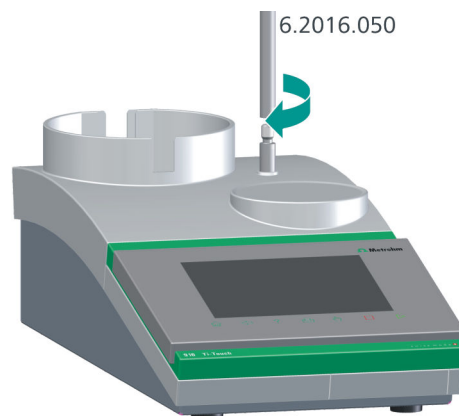

Figure 1 Without stirrer connector, depending on the product version

Mounting the stand





Plugging in the power cord



WARNING

An incorrect supply voltage can damage the instrument.

Operate the instrument only with the supply voltage specified for it. Use the supplied power supply unit exclusively.



NOTICE

The plug of the power supply unit is protected against accidental disconnection of the cable by means of a pull-out protection feature. If you wish to pull out the plug, you need to pull back the outer plug sleeve marked with arrows.

Connecting a propeller stirrer 802 Stirrer (depending on the product version)



Connecting an 800 Dosino to MSB 1

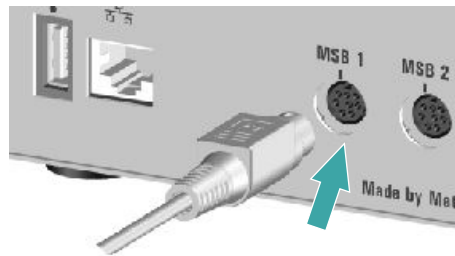

Observe the marking on the socket.



NOTICE

No additional stirrer may be connected to the MSB 1.

Connecting the iConnect

Connecting the 6.2168.000 mini USB adapter cable to an instrument

If the mini USB adapter cable is not connected to the instrument yet, proceed as follows:

- 1 Plug the mini USB adapter cable (2) into the **iConnect** connector of the instrument (1). Observe the correct orientation (markings).

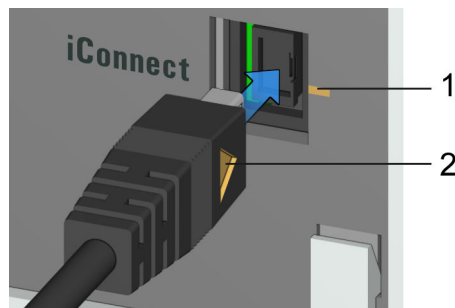

Depending on the instrument's model version, there may be several **iConnect** connectors.

- 2 Leave the adapter cable plugged in to protect the connector inside the instrument (1) against mechanical impact.



Connecting the 854 iConnect to the adapter cable

Make sure that the mini USB adapter cable is connected to the instrument.

The 854 iConnect can also be connected while the instrument is switched on.

- 1 Plug the plug of the 854 iConnect (3) into the socket of the mini USB adapter cable (2). Observe the correct orientation (markings).

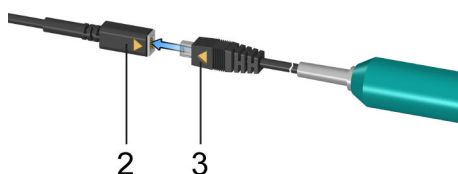

As soon as the instrument is switched on, the 854 iConnect is detected automatically and entered as measuring input into the device properties.

Connecting the electrode

The 854 iConnect is used as measuring input for iTrodes (electrodes with integrated memory chip).

Connect the electrode as follows:

- 1 Remove the protective cap of the 854 iConnect.

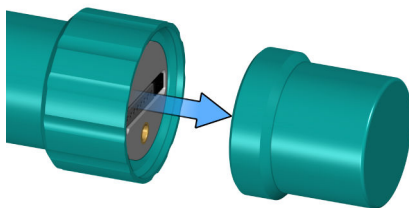

- 2 Align the guide pin (5) of the electrode with the recess in the 854 iConnect (4).

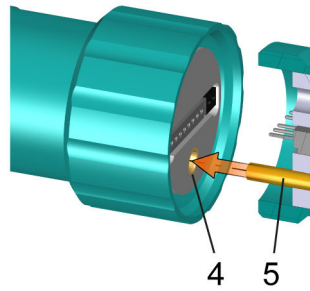

- 3 Attach the electrode to the 854 iConnect.

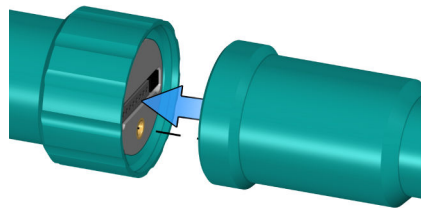

The guide pin guarantees correct connection in such a way that the contact pins cannot be damaged.

- 4 Tighten the screw cap by hand.

If there is an electrode in the sensor list of the firmware or software, the electrode is detected automatically when connecting it.



NOTICE

Mount the protective cap again as soon as the 854 iConnect is not in use anymore and no electrode is connected.

Removing the 854 iConnect

The 854 iConnect can also be removed while the instrument is switched on.

- 1 Unplug the 854 iConnect (3) from the socket of the mini USB adapter cable (2).

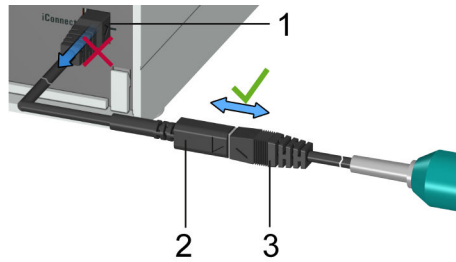

- 2 Leave the mini USB adapter cable (2) plugged into the socket of the instrument (1).



NOTICE

Position the mini USB adapter cable in such a way that it cannot be removed by accident.



NOTICE

For further information on the 854 iConnect, see *Manual iConnect 854*, article number 8.854.8002.

Connecting printers or other USB devices

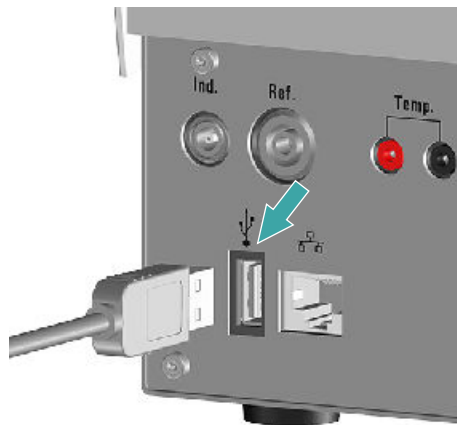

A printer can be connected directly to the USB connector (type A) (with a 6.2151.020 connecting cable), as can a USB keyboard, a barcode reader or a USB flash drive (for storing and loading methods, etc.).

If several USB devices are to be connected, then it is recommended that a USB hub (available from specialty stores) be used. The USB hub then functions as a distributor to which several USB devices can be connected.

Connecting a balance

As a rule, balances are equipped with a serial RS-232 interface. To connect a balance, you need a USB/RS-232 adapter (6.2148.050).



The USB/RS-232 adapter can be connected to the 916 Ti-Touch directly or by means of a USB hub.

Connect the 9-pin plug of the respective balance connecting cable to the RS-232 connector. Consult the manual for the balance or the manual for the 916 Ti-Touch in order to select the correct connecting cable.

The parameters for the RS-232 interface must match those on the instrument and those on the balance. For this purpose, check the manual for the balance and the manual for the 916 Ti-Touch.



2.2 Mounting the electrode holder and inserting the propeller stirrer (depending on the product version)

Mounting the electrode holder

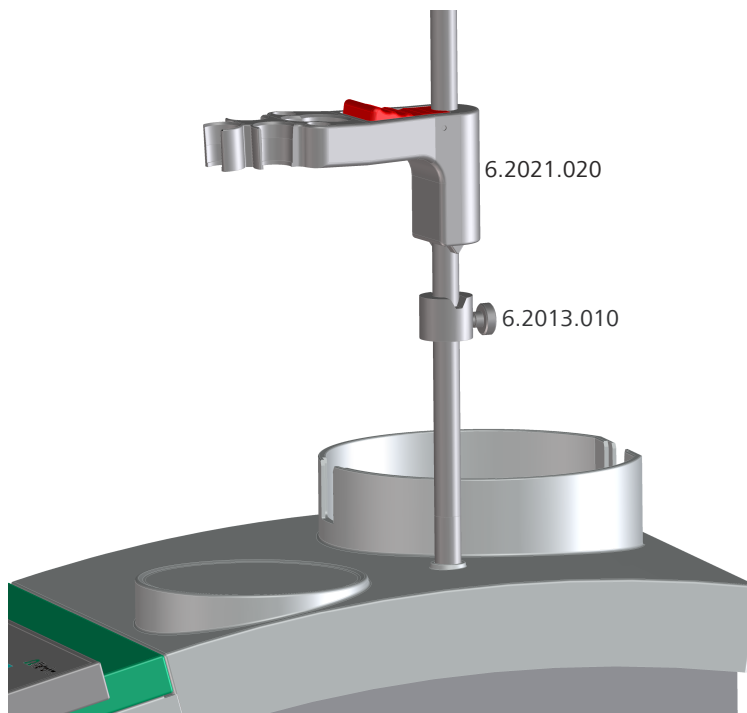

Proceed as follows:

- 1** Screw the 6.2013.010 clamping ring tightly to the support rod.
- 2** Attach the 6.2021.020 electrode holder to the support rod. Keep the locking lever pressed down until it can be released at the desired position.
- 3** Readjust the 6.2013.010 clamping ring in order to fix the position of the electrode holder. Make sure that the nose of the electrode holder is placed in the opening of the clamping ring.

Inserting the propeller stirrer (depending on the product version)

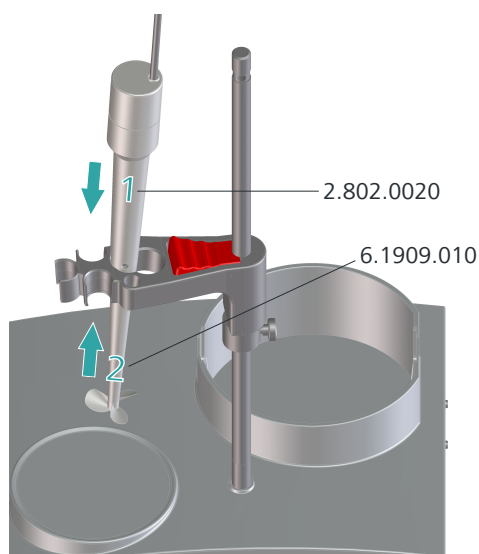

- 1** Insert the propeller stirrer *802 Stirrer* (2.802.0020) without the 6.1909.010 stirring propeller from above into the smaller of the two openings in the center of the electrode holder.

Make sure that the stirrer cable is plugged in at the rear of the device.
- 2** Plug the 6.1909.010 stirring propeller from below to the propeller stirrer.

2.3 Inserting an electrode and buret tip

General

During the titration, it is important that the solution be well-mixed. The stirring rate should be high enough for a small "vortex" to appear. If the stirring rate is too high, then air bubbles will be aspirated. This results in incorrect measured values. If the stirring rate is too low, then the solution at the electrode will not be correctly mixed. In order to ensure that measurement is carried out in a well-mixed solution following the addition of the titrant, the buret tip should be placed in a position where the turbulence is high. In addition, the distance between the addition of the titrant and the electrode should be as large as possible. Also take into account the stirring direction (counterclockwise or clockwise) when positioning electrode and buret tip.

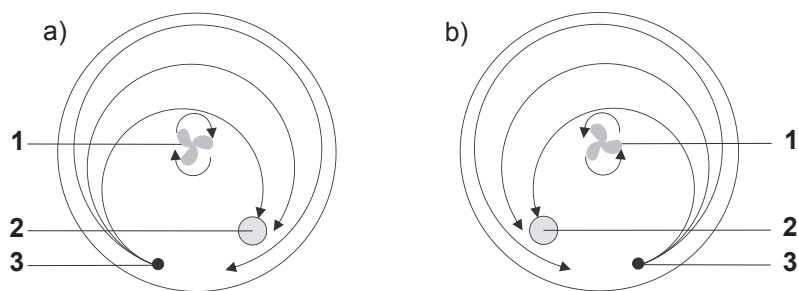

Figure 2 Schematic configuration of propeller stirrer, electrode and buret tip during a titration. a) stirring direction clockwise, b) stirring direction counterclockwise.

1 Propeller stirrer

2 Electrode

3 Buret tip

Placing an 800 Dosino with dosing unit

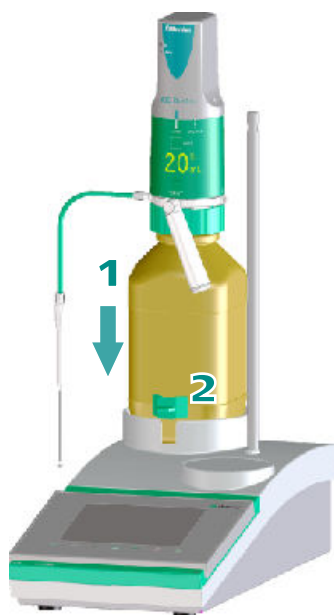

NOTICE

In the manual for the *807 Dosing Unit*, you will find information about assembling the dosing unit and mounting it on the bottle.

- 1 Place the reagent bottle with *800 Dosino* and dosing unit in the bottle holder of the 916 Ti-Touch.

- 2 Mount the holding clamps 6.2043.005 on the bottle holder so that the reagent bottle is securely fastened in place.

Inserting a buret tip and electrode

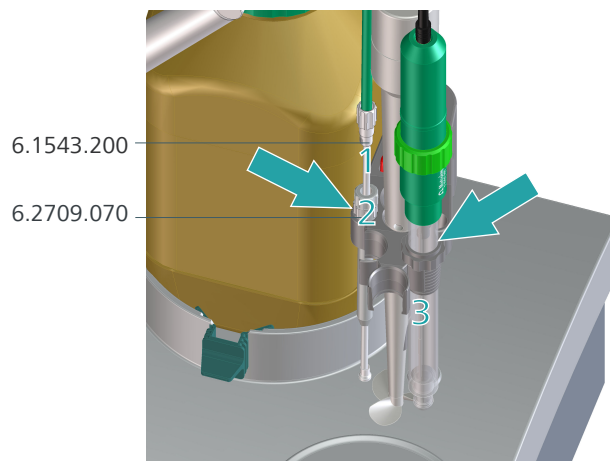

The following instruction applies for counterclockwise stirring direction. This is the default setting for the stirring direction ("+").

- 1 Insert the buret tip 6.1543.200 in the guide sleeve 6.2709.070.
- 2 Insert the guide sleeve with the buret tip into the small opening on the left at the rear.
The microvalve of the buret tip must not impede the stirring propeller.
- 3 Insert the electrode at the front on the right.
Make sure that the electrode cable is inserted at the rear of the device.



NOTICE

If a buret unit is connected, then a request appears to carry out the **Prepare** function:

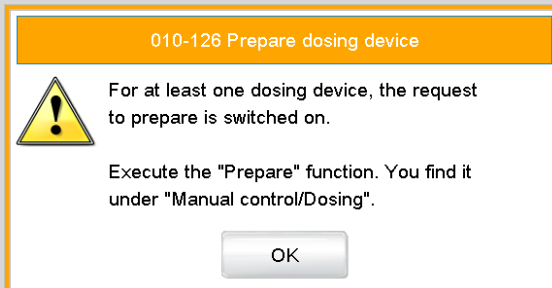

All tubings and the cylinder are rinsed with the **Prepare** function. The preparing of the buret unit is described in the *Preparing buret unit* section later in the document.

- Confirm the message with **[OK]**.

The main dialog is displayed:

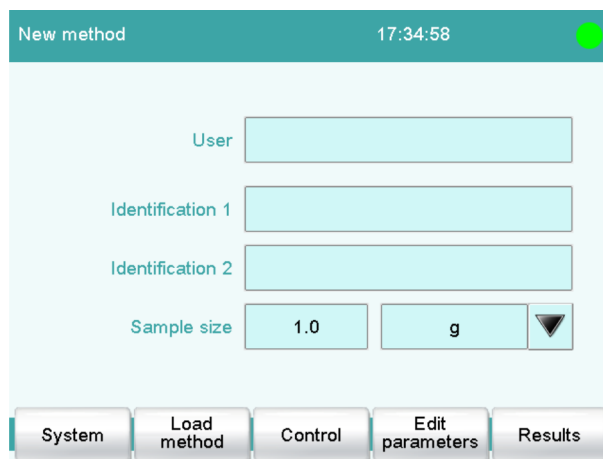

Switching off the instrument



CAUTION

The 916 Ti-Touch must be switched off by pressing the power switch on the rear of the instrument before the electricity supply is interrupted. If this is not done, then there is a danger of data loss.



Proceed as follows:

- 1 Press the power switch on the left-hand side of the back panel of the 916 Ti-Touch.

The current data is saved and the system is shut down. This process takes just a short time. At the same time, all other instruments connected to the 916 Ti-Touch via a USB cable are also being switched off.

3.2 Selecting the dialog language

The user interface is available in several languages. In addition to the two default dialog languages *English* and *German*, additional languages can be selected.

Proceed as follows to select the dialog language:

- 1 **Opening the system settings**

- In the main dialog, tap on **[System]**.
- Tap on **[System settings]**.

The **System / System settings** dialog is displayed.

- 2 **Selecting the dialog language**

- Tap on the **Dialog language** list box and select the desired language.

- 3 **Saving the settings**

- Tap on the fixed keys [] or [].

The main dialog is displayed in the respective dialog language.

4 Fundamentals of operation

4.1 Touch-sensitive screen

The entire 916 Ti-Touch user interface is touch-sensitive. Simply touch a few of the buttons on the interface to learn how a touch-sensitive screen reacts. You can always return to the main dialog by touching [].

In order to activate an element on the 916 Ti-Touch user interface, just touch the screen with your fingertip, finger nail, the eraser of a pencil or a stylus (special tool for operating instruments with touch-sensitive screens).



CAUTION

Never touch the touch screen with a pointed or sharp object such as a ballpoint pen.

In the default setting, the software is configured in such a way that an acoustic signal will be generated every time an active control is touched. This setting can be deactivated in the system settings.



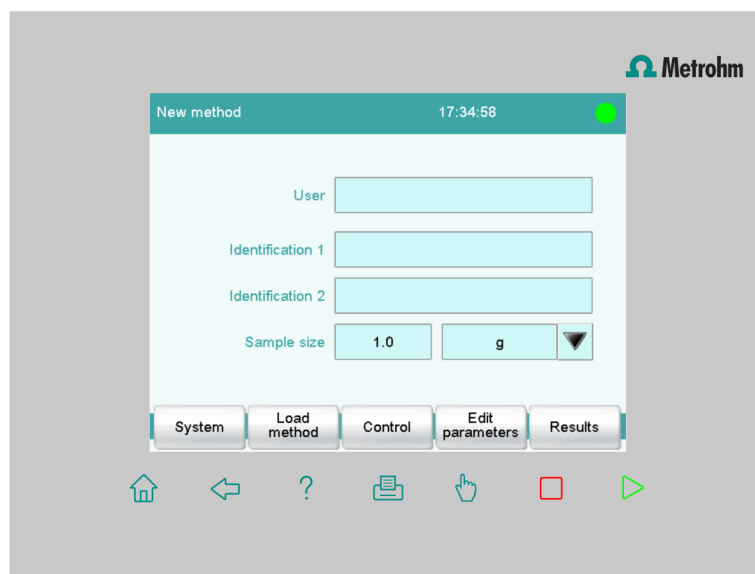



4.2 Display elements and controls



The following display elements and controls are available:





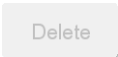



Table 1 Fixed keys which are always available

	[Home] always opens the main dialog.
	[Back] saves the entry and opens the next-higher dialog page.
	[Help] opens the online help for the dialog displayed.
	[Print] opens the printing dialog.
	[Manual] opens the manual control.
	[Stop] cancels the running determination.
	[Start] starts a determination.

The file name of the loaded method, the time and the system status are displayed in the main dialog in the **Title bar**.

In the other dialogs, the title bar shows the headings of the next upper level and of the displayed dialog. This is an aid for orientation during navigation through the user dialog.







Table 2 Screen elements

	Buttons open a new dialog when they are tapped.
	
	Inactive buttons with gray lettering indicate that the respective function is not available at the moment.
	Input fields open an input dialog when tapped.
	Tapping on the selection symbol opens a selection list.
	A check box can also be activated or deactivated by tapping on it.

4.3 Status display

The current status of the system is displayed in the upper right-hand corner of the title bar.

Table 3 Status displays

	The instrument is in normal status.
	The working medium is being conditioned.
	Conditioning has been paused.
	The working medium is conditioned.
	A method has been started.
	A method has been paused.
	An action has been started in manual control.



4.4 Entering text and numbers

In the editing dialog for text or numerical input, enter the individual characters by tapping in the input field. The following functions are available:

Text editor

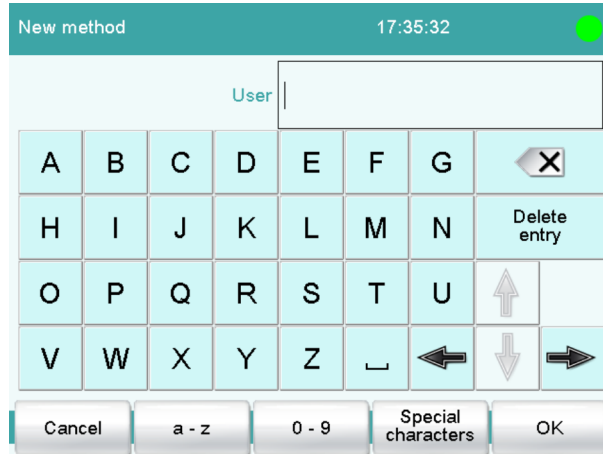

Table 4 Editing functions

[OK]	The modification is applied and the editing dialog is exited.
[Cancel]	The editing dialog is exited without applying the modification.
[Delete entry]	The content of the input field is deleted completely.
[<X]	The character in front of the cursor is deleted.
[⇐]	The cursor within the input field is shifted to the left by one character.
[⇒]	The cursor within the input field is shifted to the right by one character.
[a...z]	The lower-case letters are displayed. The label changes to [A...Z] . The upper-case letters are displayed again by tapping.
[0...9]	Numbers and mathematical characters are displayed.
[Special characters]	Special characters are displayed. You can use the button [More] to navigate through all available characters.

Number editor

Edit command / Stop conditions

Stop time s

Input:
1 ... 999999

Default value:
off

7	8	9	off
4	5	6	R1 ▼
1	2	3	
0	+/-	.	

Cancel Delete entry OK

Table 5 Editing functions

[OK]	The modification is applied and the editing dialog is exited.
[Cancel]	The editing dialog is exited without applying the modification.
[Delete entry]	The content of the input field is deleted completely.
[off]	If not only numbers but also special values (e.g., off) can be entered, then the corresponding buttons will be shown to the right of the numerical keypad.
[R1]	For many parameters, a result previously defined in the method can also be entered in place of a number. You will find precise information concerning this in the Appendix of the detailed manual. You can select the result variable by touching [R1] .



NOTICE

A commercially available USB keyboard can be connected to make text and numerical input easier.

The key assignment is described in the chapter *Device manager* of the detailed manual.



5 Setup and configuration

5.1 Preparing instruments and material

What you will need:

- A 916 Ti-Touch with mounted support rod, clamping ring and electrode holder
- One *802 Stirrer* propeller stirrer or stirring bar with built-in magnetic stirrer (depending on the product version)
- One intelligent dosing unit (IDU) with a drive of the type *800 Dosino* or
One intelligent or nonintelligent exchange unit (IEU or EU) with an *805 Dosimat*
- A pH electrode with connection cable
- A titration vessel
- Titrant, e.g. hydrochloric acid or caustic soda
- A buret tip
- Deionized water (carbonate-free)
- A USB printer with connecting cable, in case you wish to print out reports
- An analytical balance

5.2 Configuring a new titrant

You can have all of your titrants and auxiliary solutions be managed by the Ti-Touch. This has the advantage that the relevant data for these solutions (e.g. the concentration or the titer) can be calculated and monitored automatically.



NOTICE

A brand-new, intelligent buret unit must be attached before carrying out the instructions listed below. In other words, the data chip may not yet contain any titrant data.

The solutions are configured under **System ▶ Titrant**.

Proceed as follows:

1 Opening the titrant list

- In the main dialog, tap on **[System]**.

- Tap on **[Titrant]**.
- Tap on **[New]**.

You will now see an entry which depicts the attached buret unit.

Titrants / New	
Control device	Dosing device
Ti-Touch	D1
<input type="button" value="Select"/>	

- Tap on **[Select]**.

Titrants / Edit	
Titrant	<input type="text"/> ▼
Concentration	<input type="text" value="1.000"/> <input type="text" value="mol/L"/> ▼
Comment	<input type="text"/>
Titer	<input type="text" value="1.000"/> ▼
Date titer det.	2011-10-03 16:12:50
<input type="button" value="Cancel"/> <input type="button" value="Working life"/> <input type="button" value="Dosing unit"/> <input type="button" value="Titer options"/>	

2 Entering the titrant data

You can now enter the necessary data for the titrant. Each of the buttons with the selection symbol opens selection lists with useful suggestions.



- Tap on the input field **Titrant**.

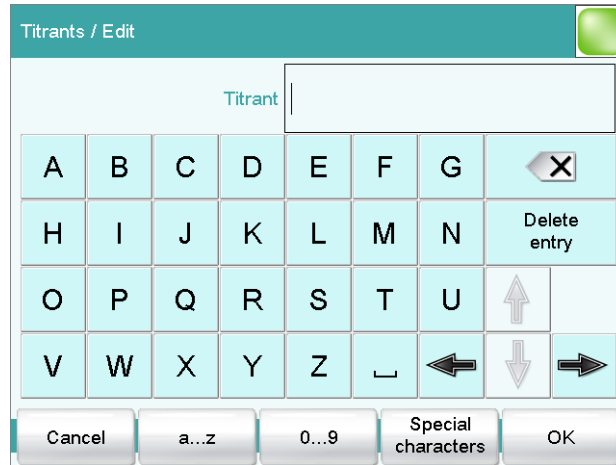

- Enter a name for the titrant.
- Confirm the entry with **[OK]**.
- Enter additional data, e.g. the titer and the concentration.
The detailed 916 Ti-Touch manual contains additional information regarding the settings which can be specified for titrants.

The new titrant has been entered in the list. The cylinder size and the type of the buret unit are displayed. In the **Dos.device** column can be seen whether or not and at which connector and instrument the titrant is attached.

System / Titrants			
Titrant	Cyl.	Type	Dos.device
c(AgNO ₃) = 0.1 mol/L	10 mL	IDU	
c(HCl) = 0.1 mol/L	10 mL	IDU	D1/Ti-Touch
c(NaOH) = 0.1 mol/L	5 mL	IDU	

**NOTICE**

If the types **IDU** (intelligent dosing unit) and **IEU** (intelligent exchange unit) are used, then data can be applied directly from the data chip.

The type **EU** (nonintelligent exchange unit) possesses no data chip. In this case, you can create the titrant yourself by tapping on **[New]**.

- 3 Return to the main dialog with the [] fixed key.

5.3 Configuring a new sensor

You can have all of your sensors be managed by the 916 Ti-Touch. This has the advantage that the relevant data for these sensors (e.g., the working life) can be monitored automatically.

The sensors are configured under **System ▶ Sensors**.

Proceed as follows:

1 Opening the sensor list

- In the main dialog, tap on **[System]**.
- Tap on **[Sensors]**.
- Tap on **[New]**.

You now see the list of the sensor types that can be selected.

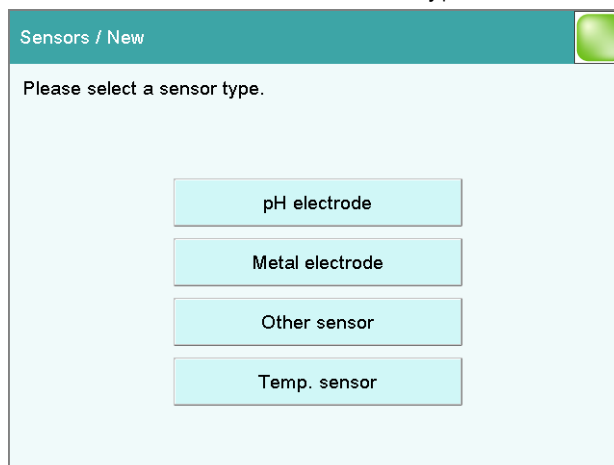

- Tap on **[pH electrode]**.



2 Entering the sensor data

You can now enter the necessary data for the sensor.

- Tap on the input field **Sensor**.

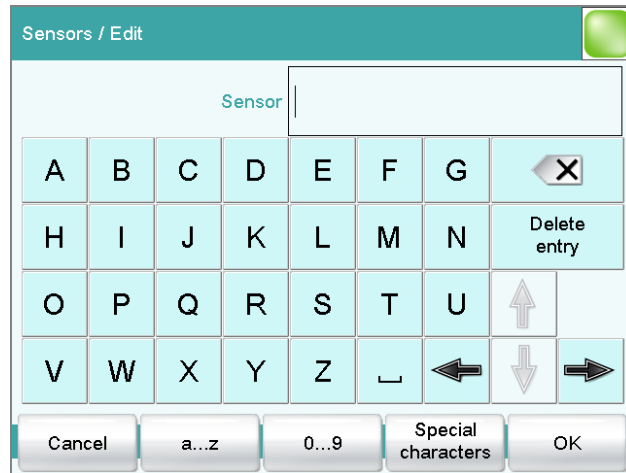

- Enter a name for the sensor.
- Confirm the entry with **[OK]**.
- Enter additional data, e.g., the serial number.
The detailed 916 Ti-Touch manual contains additional information regarding the settings which can be specified for sensors.



NOTICE

If you are working with an intelligent sensor (iTrode), then the sensor data will be adopted automatically in the Ti-Touch. A connected iTrode will be displayed in green lettering in the sensor list.

- 3 Return to the main dialog with the [] fixed key.

5.4 Configuring a printer

If you wish to print out results and titration curves, then you must configure the printer in the device manager.

Proceed as follows:

1 Opening the printer dialog

- In the main dialog, tap on **[System]**.
- Tap on **[Device manager]**.

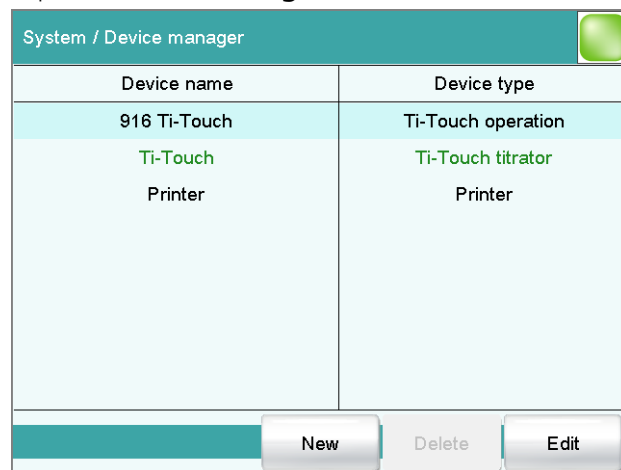

2 Entering the printer data

- Select **Printer** and tap on **[Edit]**.

Device manager / Edit

Device type: Printer

Device name: Printer

Comment:

Printer: off

Connector: USB

Buttons: PDF settings, Network printer, More options

- Tap on the selection symbol next to the input field **Printer** and select a printer type.
- Once you have connected a USB printer, tap on the selection symbol next to the input field **Connector** and select **USB**.



- If you would like to use a printer in your company network, tap on the selection symbol next to the input field **Connector** and select **Ethernet**.

You will find information as to how you connect your Ti-Touch to your company network and which settings are necessary under **Network printer** in the *Device manager* chapter contained in the detailed manual.

3 Return to the main dialog with the [] fixed key.



NOTICE

You can also compile reports as PDF files and store them on a USB flash drive or on a shared data directory in your company network.

You will find information as to which settings are necessary for releasing a data directory in the *Device manager* chapter contained in the detailed manual.

6 Carrying out simple titrations

6.1 Creating a titration method

Now create a method for a simple titration. A method contains a sequence of commands which are executed one after the other.

The acid or base content of a sample should be determined by means of a triple determination. If you have a printer connected, then a report with the result and the curve should be printed out automatically at the end of the determination.

Proceed as follows:

Creating a new method

1 Loading a method template

- In the main dialog, tap on **[Load method]** and then on **[New method]**.

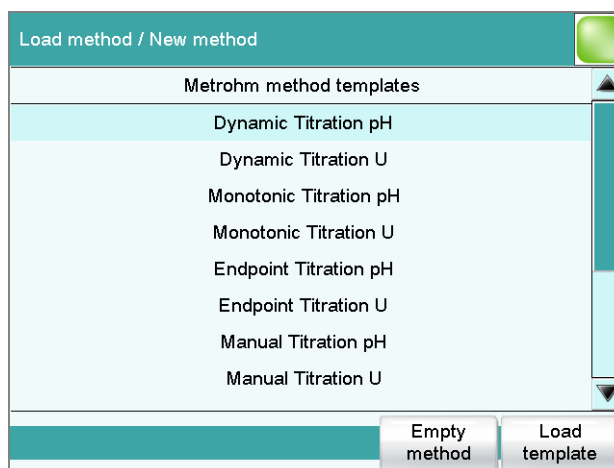

- Select the template **Dynamic Titration pH** and tap on **[Load template]**.
Use **[Yes]** to confirm any message which may appear concerning the modification of an existing method.



- In the main dialog, tap on **[Edit parameters]**.

Parameters / Sequence		
Current method: New method		
01	DET pH	Dynamic pH titration
02	CALC	Calculation
03	REPORT	Report
04	...	

Save method Method options Insert command Delete command Edit command

The new method contains three commands:

- DET pH
Contains the parameters for the titration.
- CALC
Here the calculation of the result is defined.
- REPORT
Contains the list of the individual reports which are printed out.



NOTICE

If you have not connected a printer, delete the command **REPORT**. If this is not done, then an error message will appear at the start of the determination.

Defining the titrant

1 Opening the dosing device settings

- Select the **DET pH** command and tap on **[Edit command]**.

- Tap on **[Dosing device]**.

2 Selecting the dosing device connector

- Tap on the selection symbol under Dosing device and select an MSB connector.

Make sure that the dosing device is also connected to the MSB connector that you have selected.



3 Selecting the titrant

- Under **Titrant**, tap on the selection symbol.

The list shows the previously configured titrants.

- Select a titrant and tap on **[Select]**.
- Tap on the fixed key [\leftarrow].

Defining stop conditions

1 Opening the dialog

- Tap on **[Stop conditions]**.

2 Defining a stop volume

- Tap on the input field **Stop volume**.
- Enter a value corresponding to the cylinder volume of the buret unit used.
- Apply the value by tapping on **[OK]** and close the input dialog.

3 Defining the number of equivalence points

- Tap on the input field **Stop EP**.
- Enter **2** and close the input dialog with **[OK]**.
- Tap twice on the [**↩**] fixed key.

With these parameters as stop conditions, the titration will be ended automatically as soon as two equivalent points have been found. If only one equivalence point (or even none at all) is recognized, then the titration will be ended after an entire cylinder volume has been dosed.

Defining a calculation

You will now see the three commands again in the dialog with the method run.

1 Opening the selection of result templates

- Select the **CALC** command and tap on **[Edit command]**.

Result	Result name
02 CALC	Calculation

- Tap on **[New]**.

2 Selecting a result template

- Select the result template **Content (%)** and tap on **[Load template]**.

The information window which now appears will announce that the wildcard **F1** in the calculation formula stands for the molar mass of the sample.

- Tap on **[Next]**.

3 Defining the molar mass

- Tap on the input field **F1=**.
- Enter the molar mass of the sample and confirm with **[OK]**.
- Tap on **[Next]**.

4 Defining the result properties

Now you can change the specifications for the result calculation (e.g. result name or the number of decimal places).

- Close the dialog for the calculation by tapping twice on []. You will now see once again the dialog with the three commands.

Defining the report output

1 Opening the report command

- Select the **REPORT** command and tap on [**Edit command**].

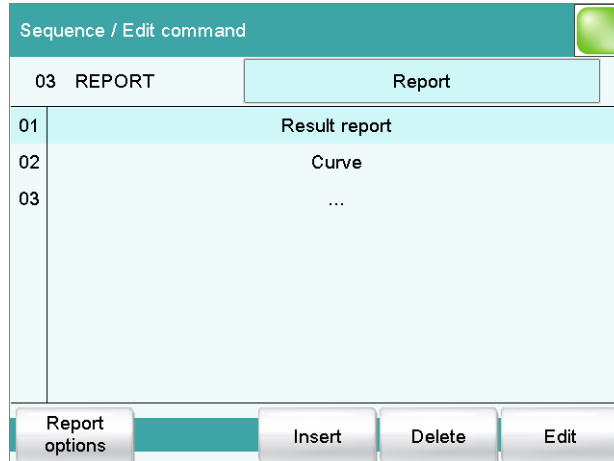

Two reports are already specified. According to these parameters, a result report and a titration curve will be printed out automatically after each determination.

2 Modifying the result report

- Select **Result report** and tap on [**Edit**].

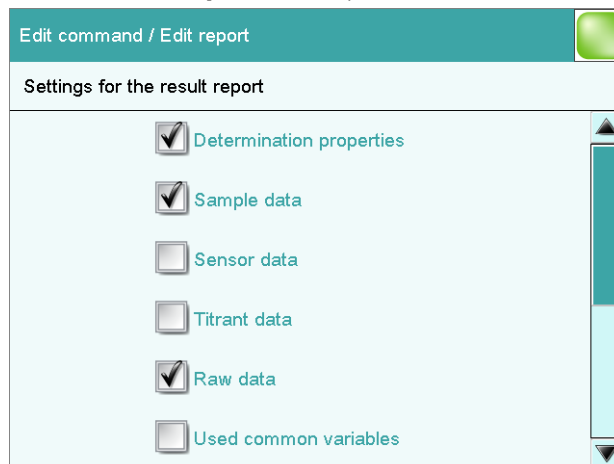

Here you can select the data which will be printed in a result report.

- Select additional data (e.g. **Sensor data** and **Titrant data**) by tapping accordingly.
- Close the dialog with the [] fixed key.



3 Defining the curve display

- Select **Curve** and tap on **[Edit]**.

Various settings can be established for the output of the titration curve.

- Tap on **[Curve options]**.

Here you can, for example, select the colors for the measurement curve or add a second type of curve.

Tap on the input field **y2 axis** and then select **ERC**. Afterwards, close the dialog with **[↩]** or **[Select]**.

The ERC curve (1st derivative) will be printed out along with the standard titration curve as a result.

- Tap on [] three times.

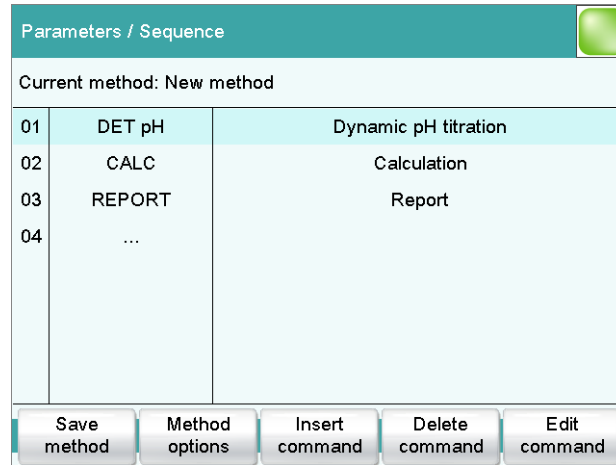

Parameters / Sequence

Current method: New method

01	DET pH	Dynamic pH titration
02	CALC	Calculation
03	REPORT	Report
04	...	

Save method Method options Insert command Delete command Edit command

Saving a method

1 Saving a method

- Tap on [**Save method**].

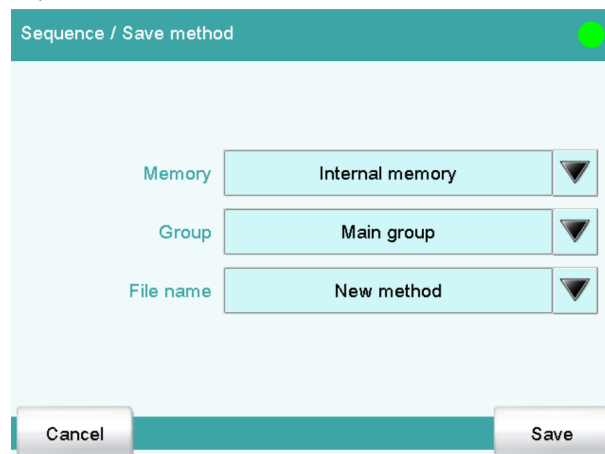

Sequence / Save method



Memory

Group

File name

Cancel Save

You can save the method in the instrument's internal memory, on a USB storage medium or in a shared data directory in a network. In addition, you can also create different groups and/or folders for the methods.

- Tap on the input field **File name**.
- Enter a name for the method.
- Use [**OK**] to confirm the entry and close the text editor.
- Save the method by tapping on [**Save**].
The method is stored in the **Main group** folder.
- Return to the main dialog with the [] or [] fixed key.

- Enter a value for the sample size.
- Confirm the entry with **[OK]**.
- Open the selection list for the unit of the sample size by tapping on the selection symbol.
- Select a unit.



NOTICE

You can also enter a unit of your own. Tap on the input field for the unit. You can use the text editor to enter any text you like.

Applying the sample size from the balance

If you have connected a balance, you do not need to open the input dialog of the sample size and the unit. On the balance, press the key (with the printer symbol) for printing the weight. The sample size and the corresponding unit are transferred to the 916 Ti-Touch and are displayed in the main dialog.



NOTICE

Consult the detailed manual for the 916 Ti-Touch to learn how you can connect and configure the balance.



NOTICE

Whether or not the sample size is entered in the main page or into the sample table depends on whether the sample table is enabled or disabled.

Proceed as follows to disable the sample table:

1 Deactivating the sample table

- Tap on **Control**.
- If the check box in front of **Sample table** is activated, then tap on it to deactivate it.
- Tap on the fixed key [].

- Tap on **[Prepare]**.
The following message is displayed:

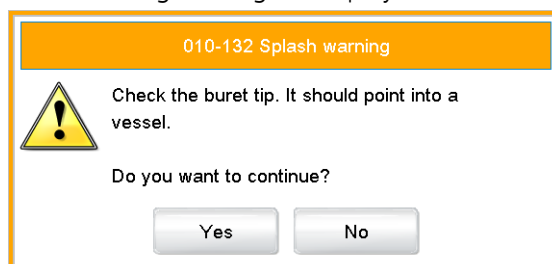

- Tap on **[Yes]**.
Preparing is carried out. The proceeding of the function is shown on the display. Details on the function **Prepare** can be found in the manual for the 916 Ti-Touch.
- Tap on the fixed key [].

Preparing the sample

1 Rinsing the electrode and buret tip (and propeller stirrer, depending on the product version)

- Place an empty vessel on the titration stand.
- Rinse electrode and buret tip (and propeller stirrer, depending on the product version) with deionized water (or with a suitable solvent) from the wash bottle.

2 Positioning the sample

- Dissolve the sample in the sample vessel with deionized water (or with a suitable solvent).
- Place the sample vessel on the titration stand.
- Immerse electrode and buret tip (and propeller stirrer, depending on the product version) in the sample solution.

6.3.2 Carrying out the titration

1 Starting the method

- Tap on the fixed key [] (= **Start**).

The determination starts. The individual steps of the methods are displayed.

At the start of the titration, the titration curve and the current values (measured value, volume, temperature) are displayed. As the titration continues, the curve is automatically scaled anew in order that the entire titration run is always visible.

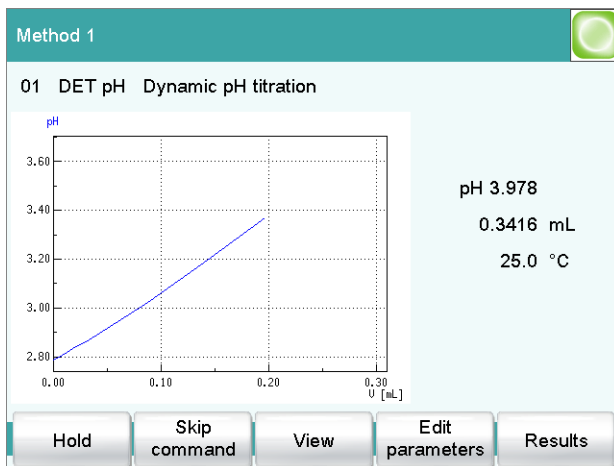

Use the [] fixed key to move to the main page while a determination is running. It is thus possible to modify individual parameters during a determination. However, only those parameters which do not decisively influence the running determination can be modified. Use the **[Live display]** button in the main dialog to switch back to the "Live" depiction of the determination.

The two defined reports are printed out after the titration if a printer has been connected and configured.

6.3.3 Displaying the results

After the determination, the result page is displayed.

The results of the last determination are always available under **Results**.

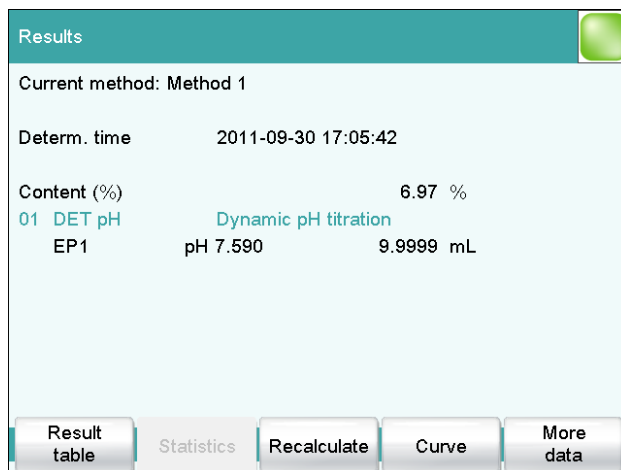

Result name and result are displayed. Furthermore, the measured value and volume of the endpoints found are displayed.

Proceed as follows to display the titration curve:

1 Displaying the titration curve

- Tap on **[Curve]**.

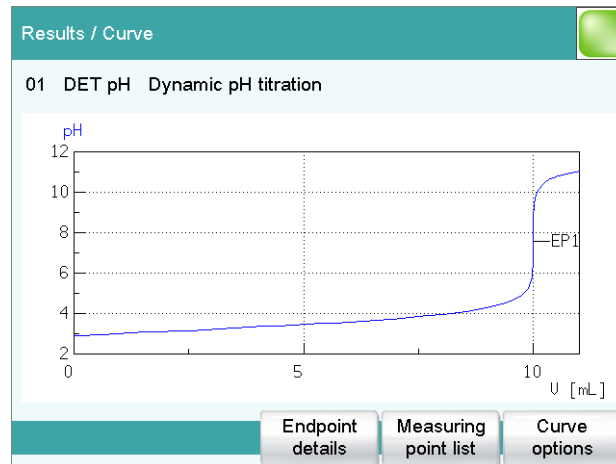

You can change the presentation of the curve under **[Curve options]**.

- Use the [\leftarrow] fixed key to return to the result page.

6.3.4 Recalculating the determination

The titration may be recalculated if needed after it has been completed.

The sample size, the calculation formula or the evaluation parameters, for example, can be modified at the time of recalculation. It is also true, however, that variables such as the end volume, the total duration of the titration or the initial measured value can be output afterwards.

The duration of the titration should be calculated as an example.

Adding and recalculating a calculation

Proceed as follows:

1 Opening the CALC command

- Return to the main dialog with the [\leftarrow] fixed key.
- Open the method with **[Edit parameters]**.
- Select the **CALC** command and tap on **[Edit command]**.

2 Adding a new calculation

- Tap on **[New]**.



- Tap on **[Create new]**.

- Tap on the input field for the calculation formula.
- Tap on **[Variables]**.

Variable	Description
C00	Sample size
C11	Sample identification 1
C12	Sample identification 2
TITER	Titer of selected titrant
CONC	Concentration of selected titrant
EP#	Volume/Quantity of endpoint EP#
MCV	End volume
MCD	Total duration of mode

- Select the variable **MCD** and tap on **[Insert]**.
- Confirm with **[OK]**.
- Tap on the input field of the result name and type in a name.
- If needed, define the result unit and decimal places.

- Use the [\leftrightarrow] fixed key to return to the calculation dialog.

Sequence / Edit command	
02 CALC	Calculation
Result	Result name
R1	Content (%)
R2	duration of titration
<input type="button" value="New"/> <input type="button" value="Delete"/> <input type="button" value="Edit"/>	

3 Initiating the recalculation

- Return to the main dialog with the [house] fixed key.
- Open the result page with [Results].
- Tap on [Recalculate].

Now two results will be displayed.

6.3.5 Printing a report manually

You can have the report of a determination printed out manually.

1 Opening the print dialog

- Press the fixed key [print].

Print	
<input type="button" value="Result report"/>	
<input type="button" value="Report seq. as def. in method"/>	
<input type="button" value="Print screenshot"/>	
<input type="button" value="Report options"/>	<input type="button" value="Clear spooler"/>
<input type="button" value="More reports"/>	

Numerous reports are available to you for printing in the print dialog.

At the top you will see the report which belongs to the previously displayed dialog window. In the case of the result window, this will



be the result report. You can also print out the same report(s) which were defined in the method (result report and curve report).

Numerous other reports, e.g. measuring point list, parameters report or titrant list, can also be selected under **[More reports]**.

2 Initiating the printing

- Tap on the selected report
or
- under **[More reports]**, select another report and tap on **[Print]**.

7 Performing titration with supplementary functions

7.1 Statistics function

The statistics function can calculate the mean value and the absolute and relative standard deviations (s_{abs} and s_{rel}) from several determinations. The calculation is carried out continuously, i.e. the calculation is updated after every determination that is carried out until the defined number of determinations has been reached.

Several results can be calculated for one determination, all of which can be incorporated in the statistical calculation.

Activating the statistics

1 Editing the method options

- In the main dialog, tap on **[Edit parameters]**.
- Tap on **[Method options]**.

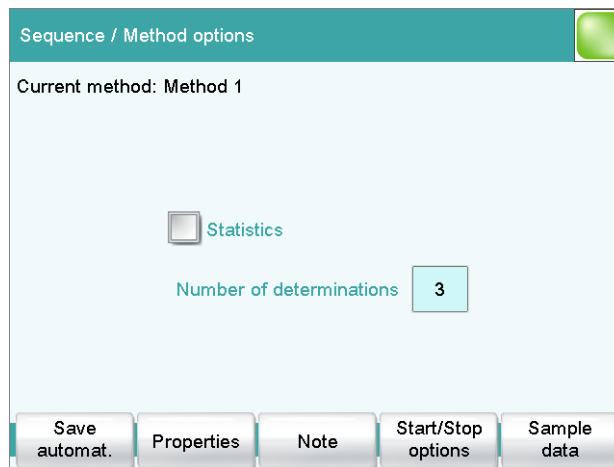

Here you can define the statistics function for this method. You can specify the number of determinations for which the respective statistical calculations are to be carried out.

These settings apply for all determinations which are carried out with this method.

- Tap on the check box **Statistics**.
- Enter a value under **Number of determinations**.
- Tap on the fixed key [**↩**].



- Select the **CALC** command and tap on **[Edit command]**.
The second calculation **Content (mol/L)** should not be incorporated in the statistical calculation.
- Select the result name **Content (mol/L)** and tap on **[Edit]**.
- Tap on **[Result options]**.

The screenshot shows a dialog box titled "Edit calculation / Result options" with a green close button in the top right corner. The main content area is light blue and contains the following elements:

- Header: "R2 Content (mol/L)"
- Section: "Variable for mean value" with a dropdown menu showing "SMN2" and a downward arrow.
- Section: "Save as titer" with a dropdown menu showing "off" and a downward arrow.
- Section: "Save as common variable" with an unchecked checkbox.
- Section: "Variable" with a dropdown menu showing "CV01" and a downward arrow.
- Bottom right corner: A button labeled "More options".

- The variable name under which the calculated mean value is to be stored is specified under **Variable for mean value**. You can change this variable assignment in order to deactivate the statistical calculation for this result.
- Tap on the selection symbol next to **SMN2** and select **off**.
- Return to the main dialog with the [] fixed key.

7.2 Saving the determination and the PC/LIMS report

You can have the determination data (measuring point list, results etc.) of a titration which has been carried out saved automatically. This makes it possible to reprocess or print out this data later. You can save the determinations to a USB storage medium or to a drive in a computer network.

If you would like to manage the determination data in a database on a PC, then you can save it in a report called PC/LIMS report or transfer it directly to a PC through a serial connection.

PC/LIMS reports can be saved either as TXT file (in accordance with ISO 8859-1) or UTF8 file.

The **tiBase** database software from Metrohm is available to you for administering the determination data on the PC.

Defining the automatic saving

Proceed as follows:

1 Opening the method options

- In the main dialog, tap on **[Edit parameters]**.
- Tap on **[Method options]**.
- Tap on **[Save automat.]**.

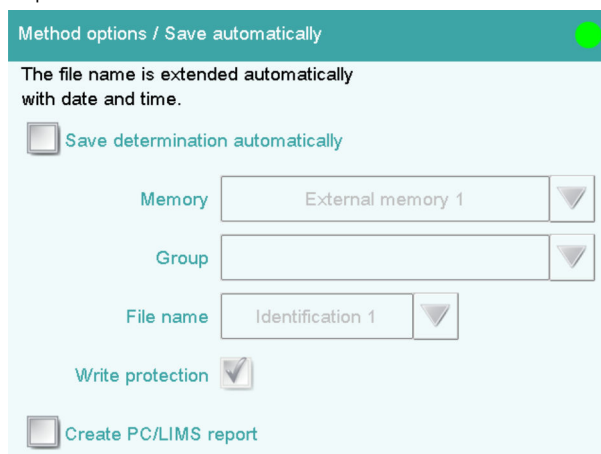

Method options / Save automatically

The file name is extended automatically with date and time.

Save determination automatically

Memory External memory 1 ▼

Group ▼

File name Identification 1 ▼

Write protection

Create PC/LIMS report

2 Activating Save determination and defining the memory location

- Activate the **Save determination automatically** check box.
- Select the memory location under **Memory**. You can choose between **External memory 1** (e.g., a USB flash drive) or **Shared memory** (memory location in a computer network).
A USB flash drive (external memory 1) must be plugged in on the 916 Ti-Touch before a determination is carried out. This memory location must already be defined in the device manager at the time of the selection of a shared memory location in a computer network. Before a determination is carried out, the 916 Ti-Touch must be connected to the network with an Ethernet cable.
- Tap on the selection symbol next to the input field **Group** and select an existing group or create a new group.
The determination data can be stored on the storage medium in various groups (= folders on the storage medium).
- Define the designation for the file name.
Two sample identifications or the method name are available for selection. If you tap on the input field **File name**, then you can enter a designation of your own for the file name.



- Activate or deactivate **write protection**.
You can protect the original determination data against overwriting.

3 Activating the PC/LIMS report and defining the memory location

- Activate the **Create PC/LIMS report** check box.
Define the memory location for the PC/LIMS report in the device manager.
- Return to the main dialog with the [] fixed key.



NOTICE

Details concerning the PC/LIMS report can be found in the detailed manual for the 916 Ti-Touch.



NOTICE

These settings are method-specific. The determination data is saved to the defined memory location for all determinations which are carried out with this method. You can define different memory locations for your methods.



NOTICE

The settings for the PC/LIMS report (memory, RS-232, coding) must be undertaken in the "Edit instrument/PC/LIMS report" dialog.

7.3 Modifying the titration parameters

You can optimize a titration run by modifying individual titration parameters according to the needs of the titration. For the following titration, the stirring rate, the dosing rate and the maximum waiting time are being modified.

Setting the stirring rate

1 Opening the stirrer settings

- In the main dialog, tap on **[Edit parameters]**.
- Select the **DET pH** command and tap on **[Edit command]**.
- Tap on **[Stirrer]**.

2 Modifying the stirring rate

- Tap on **[-]** or **[+]** to modify the stirring rate.
You can use the check box **Switch off automatically** to set whether or not the stirrer is switched off after the titration.
- Use the **[↩]** fixed key to return to the **DET pH** command.

Modifying the settings for the titration

Three pre-defined parameter sets (**slow**, **optimal** and **fast**) are available for adding the titrant and recording the measured values during the titration. These are suitable for most applications.

You can also make your own settings.

1 Modifying the dosing rate

- Tap on **[Titration parameters]**.

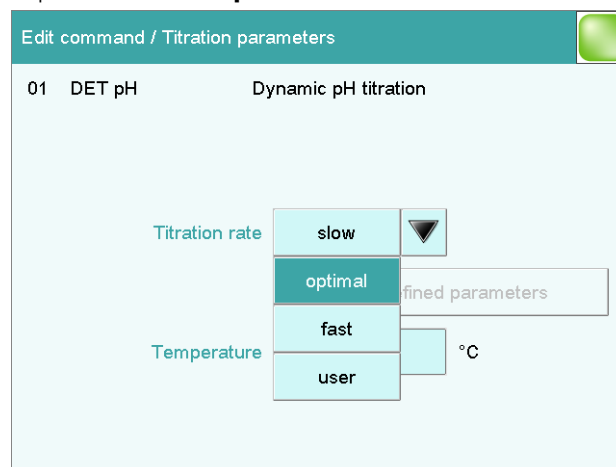



- Under **Titration rate**, select the selection **user**.
Now all of the settings of the previously set parameter set will be available under **User-defined parameters**.
- Tap on **[User-defined parameters]**.

Titration parameters / User-defined parameters	
01 DET pH	Dynamic pH titration
Meas. point density	4
Min. increment	10.00 µL
Max. increment	off µL
Dosing rate	maximum mL/min
Signal drift	50.0 mV/min
Min. waiting time	0 s
Max.	26 s

- Tap on the input field **Dosing rate**.
Maximum dosing rate means that the most rapid dosing rate possible will be applied in each case. This is dependent on the size of the dosing cylinder. If a 20 mL cylinder is used, then dosing will be twice as fast as with a 10 mL cylinder.
If you wish to specify a particular dosing rate, then you must enter a numerical value here.
- Enter a value of e.g., **20 mL/min**, and confirm with **[OK]**.

2 Modifying the maximum waiting time

- Tap on the input field **Max. waiting time**, at the bottom on the right.
This value determines the maximum time between two volume steps. If the signal drift drops below the set level before the waiting time has expired, then the next volume step will take place immediately. The maximum waiting time thus occurs only with high drift values, i.e. before and after an equivalence point.
- Enter a somewhat longer waiting time, e.g., **30 s**, and confirm with **[OK]**.
- Tap three times on the **[↔]** fixed key.
You will now see once again the method run with the three commands.

7.4 Creating a sample table

If you would like to prepare a sample series in advance, you can use the sample table. Proceed as follows:

Filling the sample table with sample data

1 Activating the sample table

- In the main dialog, tap on **[Control]**.

The screenshot shows the 'Control' dialog box with the following elements:

- Header: Control
- Checkboxes: Statistics, Sample table, Autostart
- Input fields: Number of autostarts (Table), Sample number (0)
- Buttons: Favorites, Delete table, Reset autostart, Delete statistics

- Activate the **Sample table** check box.
- Return to the main dialog with the [**←**] fixed key. A new button is now visible in the main dialog.

The screenshot shows the 'New method' dialog box with the following elements:

- Header: New method 17:41:35
- User field: D. Müller
- Text: Sample table Line 0 of 0
- Button: Sample table
- Bottom buttons: System, Load method, Control, Edit parameters, Results



2 Entering the sample data

- Tap on **[Sample table]**.

Sample table		
No.	Identification 1	Sample size
1	...	

The sample table is still empty. The first line is highlighted.

- Tap on **[Edit]**.

Sample table / Edit		
Line number	-	1
Method	▼	
New sample		
Identification 1	<input type="text"/>	
Identification 2	<input type="text"/>	
Sample size	1.0	g ▼

- Tap on the selection symbol next to the input field **Method**.
- Select a saved method.

A particular method can be selected for each sample which is to be processed. If no method is specified, then the currently loaded method is executed.

- Fill out the fields for sample identification and the sample size. The line number is automatically increased by one after the sample size has been entered. The next sample size can be entered directly. The criterion, after which the line number should be increased by one, can be modified in the properties dialog of the sample table under **[Editing options]**.

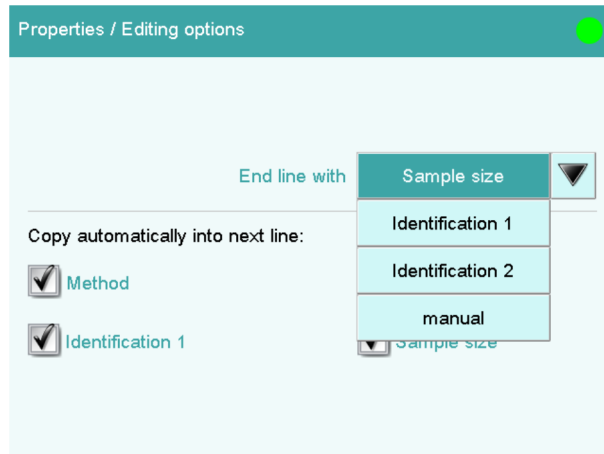

- Use the [\leftarrow] fixed key to return to the sample table.
- Switch to the main dialog with the [\uparrow] fixed key after the desired number of sample data has been filled in.

7.5 Carrying out titrations using the sample table

Now carry out the titrations with the samples for which you have entered sample data.

Each time that you press the [\triangleright] fixed key, the sample data will be loaded from the top line of the sample table and applied for the current titration. This line will be deleted at the end of the titration. The sample data of the next line down will be used for the next titration.

A result report will be printed out and a PC/LIMS report will be saved after each titration if you have defined or activated these options.



NOTICE

The sample table can also be used with automated determinations.



8 Setting up the user administration

If different persons are working on the instrument, we recommend that the user administration of the 916 Ti-Touch be used. This means that everyone can use their user identification to log on to the instrument. The reports will then automatically contain the respective user name.

In addition, a dialog level can be set up for each user. In addition to the expert dialog, with access to all functions and settings, a routine dialog can be selected with limited access rights. The available functions and dialog areas can be configured for the routine dialog.

Administrator rights can be assigned to users who are permitted to administer methods and to make configuration settings.

If you create a user list, then you can use it in different ways. You can apply different combinations of login options. Three possibilities are listed in the following:

- User name can be selected in the main dialog without login
- Automatic login with USB flash drive
- Login with password

8.1 Creating a user list

The creation of a user list is required for all of the possibilities of the user login.

Defining users

Proceed as follows:

1 Opening the user administration

- In the main dialog, tap on **[System]**.
- Tap on **[System settings]**.
- Tap on **[User admin.]**.

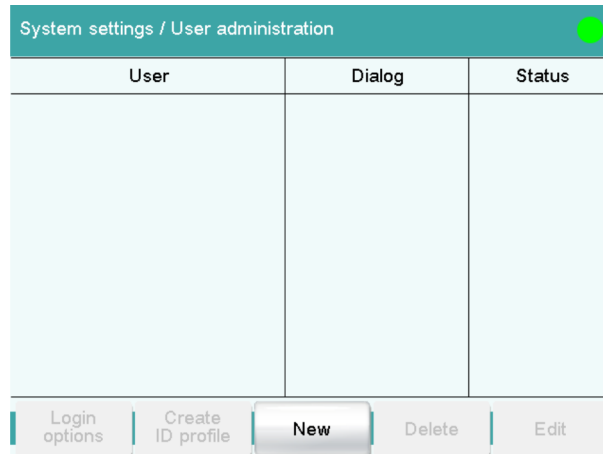

2 Creating a new user

- Tap on **[New]**.

User administration / Edit user

User:

Full name:

Dialog: Expert dialog ▼

Status: active ▼

Admin. rights:

Buttons: Cancel, Favorites, Signature method, Signature determ.

- Tap on the input field **User** and enter an unambiguous user identification (e.g., abbreviation). Close the input dialog with **[OK]**.
- Tap on the input field **Full name** and enter the name of the user. Close the input dialog with **[OK]**.
- Tap on the selection list **Dialog** and select either **Expert dialog** or **Routine dialog**. Remember that the system settings cannot be changed except in the expert dialog. The setting is effective only when working with login.
- Activate or deactivate the administrator rights. The user administration can be used only with administrator rights. At least one person must be in possession of administrator rights.
- Return to the user administration with [].
- Define additional users.
- Return to the main dialog with [].



If you would like to work without a login, it is sufficient to create a user list. Each user can select his or her entry from the user list in the main dialog. Then the user name will be printed out with reports and/or saved along with a determination.

8.2 Automatic login with USB flash drive

It is possible to have automatic user recognition without requiring that a password be entered. If each user uses a USB flash drive of his or her own with his or her user profile, then the instrument can recognize whose USB flash drive it is at the time of the switching on. User login then takes place automatically.

The USB flash drive can be used for saving determination data, methods, PC/LIMS reports or for backing up the entire system.

Creating user profiles

You now need to create an ID profile for each user on a separate USB flash drive. The USB flash drive must be formatted.

Proceed as follows:

1 Plugging in the USB flash drive

- Return to the main dialog with [].
- Plug in a USB flash drive into the rear of the 916 Ti-Touch.
- Wait until a message appears which confirms that the USB flash drive has been recognized.

2 Saving the user profile

- Switch over to the user administration with **[System]**, **[System settings]** and **[User admin.]**.
- Select a user name.
- Tap on **[Create ID profile]**.

A message will appear which confirms the creation of the ID profile.

If you now set the login options, you will automatically be logged in at once with this ID profile.

Setting the login options



NOTICE

The following steps are possible only if the user has administrator rights.

Proceed as follows:

1 Opening the login options

- In the user administration, tap on **[Login options]**.

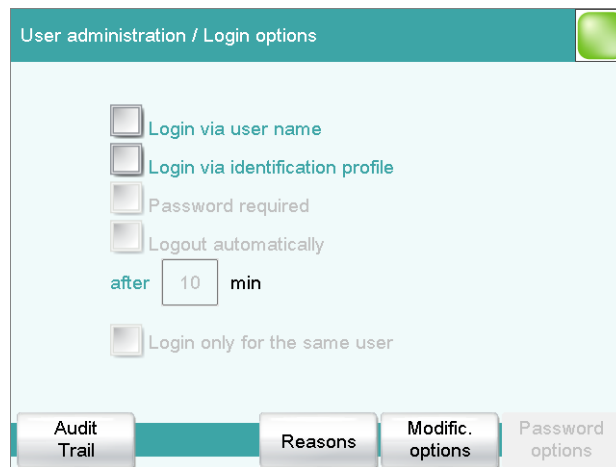

2 Activating login with ID profile

- Activate **Login via identification profile**.
- Deactivate all other settings.
- Return to the user administration with **[↩]**.

You can confirm the request following the creation of ID profiles with **[Yes]** if you have created an ID profile beforehand. Make sure that the USB flash drive is plugged in.



NOTICE

If you have not yet created any ID profiles, then you must confirm the request with **[No]**. Then you can deactivate the **Login via identification profile** and create an ID profile in the user administration.

Confirm any messages which may appear with **[Yes]**.

An automatic login will now take place.



3 Logging in

- Tap on **[OK]** after the request that you plug in the USB flash drive with your ID profile.
- In order to log in another user with ID profile, tap in the main dialog on **[Control/ Logout]** and afterwards on **[Logout]**.
The request appears once again to plug in a USB flash drive.

8.3 Login with password

If you wish to make it imperative that each user log in on the instrument with a password, then you can activate this in the login options.



NOTICE

Please note that you will no longer be able to delete the entries created in the user administration once you have activated the password request. The only option available afterwards is to deactivate users.

Setting the login options

Configure the following settings:

1 Opening the login options

- Use **System ▶ System settings ▶ User admin.** to switch over to user administration.
- Tap on **[Login options]**.

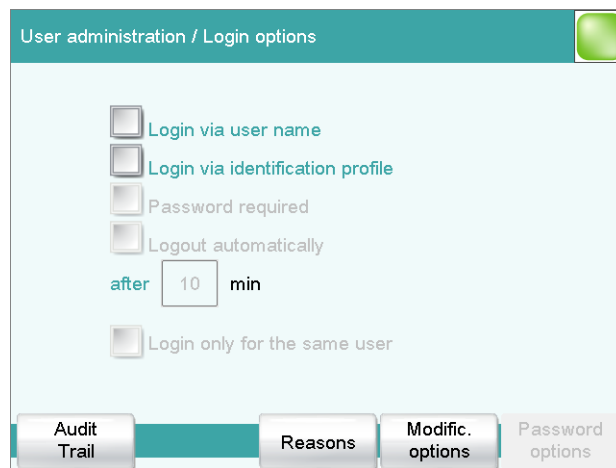

2 Adjusting the settings

- Activate **Login via user name**.

- Activate **Password required**.

Many settings are possible in the login options. Consult the manual of the 916 Ti-Touch to look these up if necessary.



NOTICE

The login dialog is called up as soon as you exit the login options dialog with [] or []. You must then log in for the first time. You must define and enter a password to accomplish this.

If the login dialog is not called up, switch the instrument off and then back on again.

First login

You must define a password at the time of the first login on the instrument. Proceed as follows:

1 Entering the user name

- Tap on the input field **User**, enter the user name and confirm with [**OK**].
- Tap on [**Change password**].

