

Configuring the Dionex Modular HPIC system with an inline water purifier and inline calibration for trace anion determinations in ultrapure water

Author

Terri Christison, Daniel Khor, and Jeff Rohrer, Thermo Fisher Scientific, Sunnyvale, CA

Keywords

Dionex IonPac AS17-C, RFIC, Reagent-Free IC, Electrolytic Water Purifier, AutoPrep

Goal

To provide instructions for installing a trace anion application using the Thermo Scientific™ Dionex™ AutoPrep and Thermo Scientific™ Dionex™ EWP Electrolytic Water Purifier modules on the Thermo Scientific™ Dionex™ ICS-5000+ HPIC™ system.

Introduction

In the electronics industry, ionic contamination, in the range of parts per trillion (ppt, ng/L) to parts per billion (ppb, µg/L) concentrations, is a major concern. This contamination can cause corrosion-related failures, poor product quality, low product yields, and shortened product life. Although ionic contamination methods are well established, ionic contamination is increasingly important and more challenging as the devices decrease in size.¹⁻⁶ Therefore, monitoring and minimizing ionic contamination are important; however, trace ion analysis continues to be challenging. The lab environment and the IC system cleanliness can significantly impact the baseline contamination, limiting the analytical sensitivity in trace analysis methods.

Recently, automated calibration and water purification on a compact ion chromatography system were demonstrated to minimize the system and environmental contamination and resulted in increased sensitivity to double-digit-ppt concentrations.^{7,8} However, this method is also needed on the Dionex ICS-5000+ HPIC dual IC system. When combined with the advantages and ease-of-use of a Reagent-Free™ (RFIC) system, the low baseline contamination yields increased reproducibility, greater quantification accuracy, greater sensitivity, and reliable results.

This technical note demonstrates the configuration of one system of the dual Dionex ICS-5000+ system with the Thermo Scientific™ Dionex™ AS-HV high volume autosampler, the Dionex EWP Electrolytic Water Purifier, and Dionex AutoPrep module to determine trace anions in ultrapure water.

Equipment

- Dionex ICS-5000+ HPIC system, including:
 - DP Dual Pump module (one channel only) or SP Single Pump module
 - EG Eluent Generation module
 - DC Detector Column Oven module with one CD Conductivity Detector
 - AM Automation Manager module with one 10-port valve, P/N 075951
 - EO Eluent Organizer with at least one 2 L eluent bottle
 - 4 L eluent bottle
- Thermo Scientific™ Dionex™ RFIC-ESP™ Water Purifier option
 - Dionex EWP Electrolytic Water Purifier Kit for Anion Analysis, P/N 072629
 - Dionex AutoPrep module (large loop, small loop), P/N 066342
- Thermo Scientific™ Dionex™ Reagent-Free RFC-10 or RFC-30 module to power the EWP module (suppressor connection)
- Dionex AS-HV Autosampler* with PEEK probe, peristaltic pump option (P/N 064508), one 2 L eluent bottle, and 250 mL culture flask tray

* Note that the computer requires an RS-232 port or an RS-232 to USB adapter.



Dionex ICS-5000+ HPIC system

Software

Thermo Scientific™ Chromeleon™ 7.2 Chromatography Data System (CDS) software, SR4 release.

Table 1 lists the consumable products recommended for the Dionex ICS-5000+ HPIC system configured for suppressed conductivity detection and trace analysis with the Dionex AS-HV autosampler, Dionex EWP Electrolytic Water Purifier, and Dionex AutoPrep modules.

Reagents and standards

- 18 M Ω -cm resistivity degassed deionized (DI) water
- Standard II, NIST traceable (P/N 057590) for a second source standard Fisher Scientific reagents, Certified ACS grade
 - Sodium bromide, P/N S255-500
 - Sodium chloride, P/N S271-500
 - Sodium fluoride, P/N S299-500
 - Sodium nitrite, P/N S347-500
 - Sodium nitrate, P/N S343-500
 - Sodium sulfate, P/N S421-500
- Fisher BioReagents: Sodium phosphate, monobasic, P/N BP329-500

Table 1. Consumables list for the Dionex ICS-5000+ HPIC System.

Product Name	Description	Part Number
Thermo Scientific™ Dionex™ EGC 500 KOH cartridge	Eluent generator cartridge recommended for this application	075778
Thermo Scientific™ Dionex™ CR-ATC 500 Electrolytic trap column	Continuously regenerated trap column used with Dionex EGC KOH 500 cartridge on the Dionex ICS-5000+ systems	075550
Thermo Scientific™ Dionex™ HP degasser module	Degasser installed after Dionex CR-TC trap column and before the Injection Valve. Used with eluent generation	075522
Thermo Scientific™ Dionex™ AERS™ 500e suppressor	Recommended suppressor for 4 mm and 5 mm columns, using external water mode	SP6952
Thermo Scientific™ Dionex™ IonPac™ AG17-C column	Anion guard column, 4 × 50 mm	066295
Dionex IonPac AS17-C column	Anion separation column, 4 × 250 mm	066294
Dionex IonPac UTAC-LP2 column	Anion concentrator column, 4 × 35 mm	079917
Thermo Scientific™ Dionex™ CRD 300 Carbonate Removal Device, 4 mm	The high capacity inline sample degasser. Removes carbonate prior to sample concentration	064637
Dionex AS-HV Autosampler items	Thermo Scientific™ Nunclon™ sample flasks, 250 mL, with caps and septa (pkg. of 50)	064235
	Serial to USB converter cable. Included with autosampler	064261
	Additional peristaltic tubing, Santoprene™ (Exxon Mobile): 2.06 mm i.d., each	064521
	Additional peristaltic tubing, Santoprene: 0.64 mm i.d., each	064825
	Alternative septa: food grade aluminum foil which is cleaner than most septa	N/A
Dionex EWP Electrolytic Water Purifier Kit for Anion Analysis	Provides continuous purified water for eluent generation, to the suppressor, transfer water, and diluent. The installation kit is included.	072629
Accessories for Dionex EWP and RFC 10 modules	Twisted pair wire cable, included in Dionex ICS-5000+ DP or SP pump module ship kit	060611
	Connector for twisted pair cable to interface the RFC 10 module to the DP module. Included in Dionex ICS-5000+ DP ship kit	923968
	2-pin green connector, included in the ship kit	921019
Dionex AutoPrep system (large loop, small loop)	The small loop allows for automated calibration. The large loop is used for sample loading.	066342
4 L Eluent Bottle Assembly	Recommended for 1 mL/min flow rates	063292

Chromatographic Conditions

Columns	Thermo Scientific™ Dionex™ IonPac™ AG17-C guard, 4 × 50 mm Dionex IonPac AS17-C separation, 4 × 250 mm		
Gradient		Time	KOH (mM)
	Samples*	-21.5	50
	Calibration/EWP*	-15.0	50
		-15.1	1
		0.0	1
		4.0	1
		10.0	12.5
		20.0	20
		25.5	35
		30.0	35
Eluent Source	Dionex EGC 500 KOH eluent cartridge, Thermo Scientific™ Dionex CR-ATC™ 500 and high pressure degas module		
Flow Rate	1.0 mL/min		
Column Temperature	35 °C		
Detection/Suppressor Compartment	15 °C		
Detection	Suppressed conductivity, Dionex AERS 500e suppressor, 4 mm, external water mode (driven by system pump)		
Concentrated Volume	Standards: Incremental additions of 10 µL; Sample Volume: 10 mL		
Sample Flow Rate	~3.5 mL/min (Dionex AS-HV autosampler peristaltic pump)		
Standard Flow Rate	~0.5 mL/min (Dionex AutoPrep small loop, gravity)		
Concentrator	Dionex IonPac UTAC-LP2, 3 × 35 mm		
Run Time	Calibration Standards: 41.5 min; Samples and Check Standards: 51.5 min		
Background Conductance	<1 µS		
Noise	<1 nS		
System Backpressure	~2200 psi		

* The sample run times include loading and equilibration 21.5 min before the injection. Standards require less loading time, so the run time is 15 min before injection.

Standard preparation

For trace analysis using the Dionex AutoPrep system, it is convenient to use a combined stock standard prepared at the same concentration. Prepare individual 1000 mg/L stock standards by dissolving the amount of reagent shown in Table 2 into a 125 mL HDPE bottle. Add 100 g of DI water, cap the bottle, and invert to mix. Store the standard at 20 °C until it is needed.

The Dionex AutoPrep system allows standards to be prepared at 100–1000× higher concentrations than needed for ppb and ppt calibration standards, thereby minimizing the impact of contamination. For calibration standards needed at ppb concentrations, prepare the working standard at 100× higher concentration than the lowest calibration concentration. For ppt calibrations, prepare a 1000× higher concentration standard than the lowest calibration concentration.

Table 2. Amount of reagent to prepare 100 g of individual 1000 mg/L standards.

Anion	Compound	Amount of Reagent (mg)	Amount of Deionized Water (g)
Fluoride	Sodium fluoride (NaF)	221	100
Chloride	Sodium chloride (NaCl)	165	100
Nitrite	Sodium nitrite (NaNO ₂)	150	100
Bromide	Sodium bromide (NaBr)	129	100
Nitrate	Sodium nitrate (NaNO ₃)	137	100
Phosphate	Sodium phosphate, monobasic (NaH ₂ PO ₄)	126	100
Sulfate	Sodium sulfate (Na ₂ SO ₄)	148	100

To prepare the 10 mg/L combined intermediate standard, add 1 g of each 1000 mg/L individual stock standard to a 100 mL HDPP bottle. Add DI water to a final weight of 100 g. Cap the bottle and invert to mix. Store the standard at 20 °C until it is needed.

To prepare 1 L of 50 ppb stock standard for calibrations using the Dionex AutoPrep system small loop, dilute 5 g of the 10 mg/L combined standard in DI water to 1000 g total weight. Connect the solution to the small loop. Place a 1 ft piece of black backpressure tubing (or sufficient length to result in a 0.5 mL/min flow rate) on the Dionex AutoPrep system small loop waste line. Use a syringe on the waste line to start gravity feed. Measure the flow rate with a timer and a 5 mL graduated cylinder. Adjust the length of the backpressure tubing to achieve an approximate 0.5 mL/min flow rate.

To calibrate the large-loop-to-small-loop ratio, prepare a 5 ppb working bromide standard, by diluting the 50 ppb bromide stock standard, 10-fold, respectively with DI water for the large loop and the small loop respectively. Prepare this calibration standard just prior to use.

Instrument setup and installation

The Dionex ICS-5000+ HPIC system is a high-pressure, modular dual IC system. This system, the Dionex EGC 500 KOH cartridge, and Dionex CR-TC 500 Continuously Regenerated Trap Column consumable products are designed for high pressure conditions up to 5000 psi. To set up this application, connect the Dionex ICS-5000+ HPIC system, Dionex AS-HV Autosampler, Dionex EWP Electrolytic Water Purifier, and Dionex AutoPrep system as shown in Figure 1. Notice that the flow path from the pump to the CD Conductivity Detector is similar to that of most IC systems.

Install the Dionex Automation Manager AM with a 10-port valve into the Dionex ICS-5000+ DC module (while the module is powered off). Connect the USB cables from the Dionex ICS-5000+ HPIC system modules: from DP to EG, EG to DC, and DC to the computer. Connect the RS232 cable via RS232-USB cable from the Dionex AS-HV Autosampler to the computer. Connect the power cables and power-on the IC instrument and the autosampler.

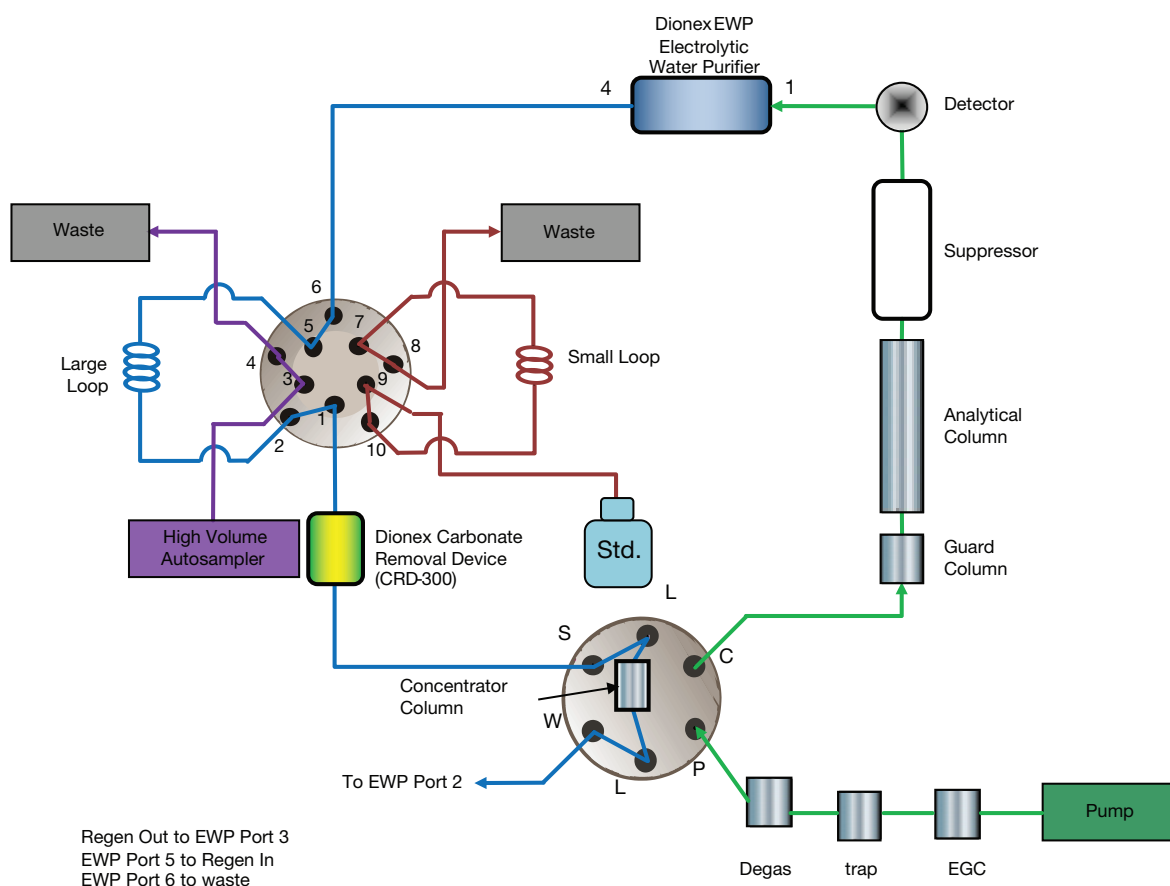

Figure 1. Flow diagram.

Configuring the modules in the Chromeleon CDS software

To configure the IC system:

1. Start the Chromeleon Instrument Controller program.
2. Select the link, *Configure Instruments to open* the Chromeleon Instrument Configuration Manager program.
3. Right-click on the computer name.
4. Select *Add an Instrument*.
5. Enter an appropriate name (for example: ICS-5000+_Trace_1).
6. Add the modules (ICS-5000 DP, EG, DC, and AS-HV autosampler and Dionex AutoPrep) to this instrument configuration (Figure 2).

The detailed information is summarized in Table 3. In this technical note, System 2 pump, valve and EGC were used. The Dionex EWP Electrolytic Water Purifier is not added to the Chromeleon Instrument configuration because it is controlled manually by the Dionex RFC-10 module. An alternative configuration option (not shown here) involves using the unused suppressor power port of the second system of the Dionex ICS-5000+ HPIC system to power the Dionex EWP Electrolytic Water Purifier module.

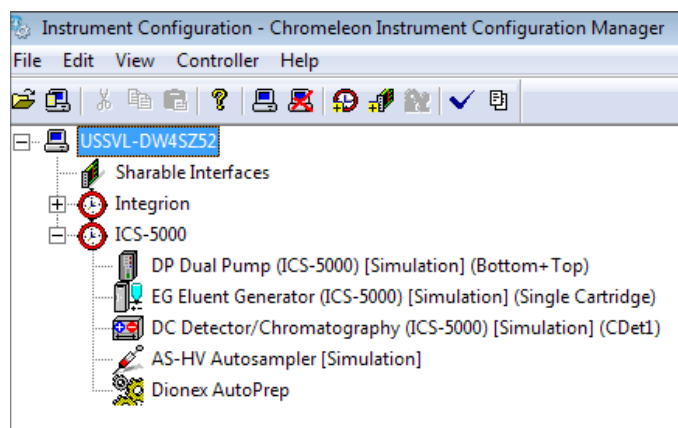

Figure 2. Creating a configuration.

Table 3. Configuring the Dionex ICS-5000+ IC modules with the Dionex AS-HV high volume autosampler and Dionex AutoPrep system.

Module	Tab	Action
DP Dual Pump	General	Select module address in Browse box
	Device	Link Pump_2 to Instrument.
	Bottom Pump	Click on Pump_Relay_2, select Flow Zero (Figure 3)
EG Eluent Generator	General	Select module serial number
	Cartridges	Link to Instrument, check EGC-2 box for one cartridge, link to Pump_2
DC Detector / Chromatography	General	Select instrument, select module serial number
	Detectors	Select CDet1, double-click on CDet1, Link to Pump_2, Check CD_1 and CD_1_total signal boxes
	Thermal Controls	Check Compartment_TC, and Column_TC
	Suppressors	Double click Suppressor2, Link to Pump_2
	High Pressure Valves	Double click InjectValve_1, select Controlled by DC (Figure 4). Double click AM-HP_1, select Controlled by DC
AS-HV Autosampler	Low Pressure Valves	Remove check marks
	General	Select COM7 for serial communication (Figure 5)
Dionex AutoPrep system	Options	Select Rack Type, Internal Peristaltic as the pump (sample loading pump), Pull mode, Sample Loop (Figure 5)
		No entries needed

Dionex DP dual pump module

Set Pump Relay_2 to “Zero Flow”. When the pump turns off, Relay 2 turns-off the Dionex RFC-10 module which subsequently turns-off the Dionex EWP Electrolytic Water Purifier module. Similarly, both modules are turned-on when the pump turns-on (Figure 3).

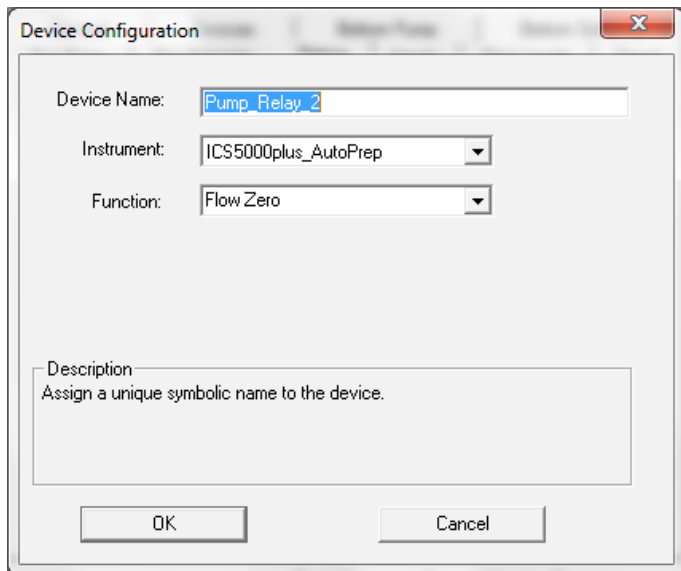
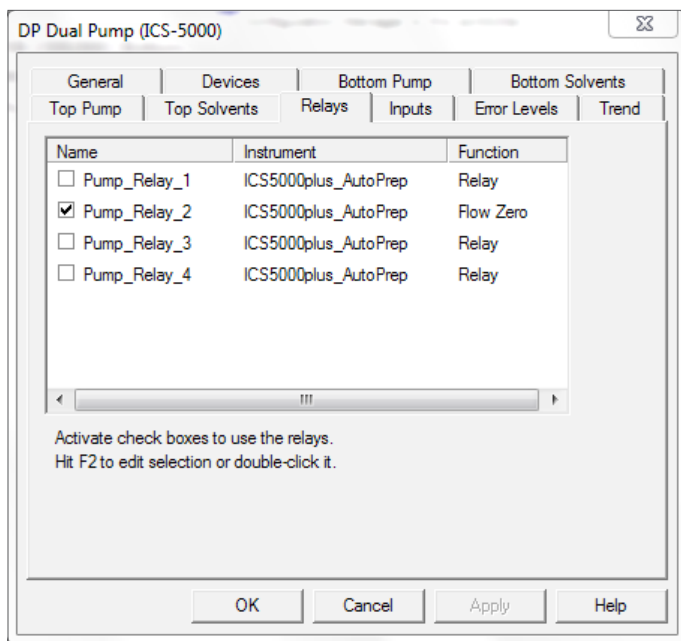

Figure 3. Activates pump relay 2 to turn off and turn on the Dionex EWP Electrolytic Water Purifier module.

Dionex DC detector/chromatography module

In the Dionex AutoPrep system module, samples (~10 mL, large loop) and standards (10 µL, small loop) use different injection loops requiring valve switches during loading and concentrating. To set control of both valves (*InjectValve* and *AM_HP1 valve*), select the High Pressure Valves tab of the Dionex ICS-5000+ DC module. Double-click on *InjectValve* and select *DC* (Figure 4). The AM-HP1 is controlled by the DC module by default. The valves will be programmed manually (Creating Instrument Programs section).

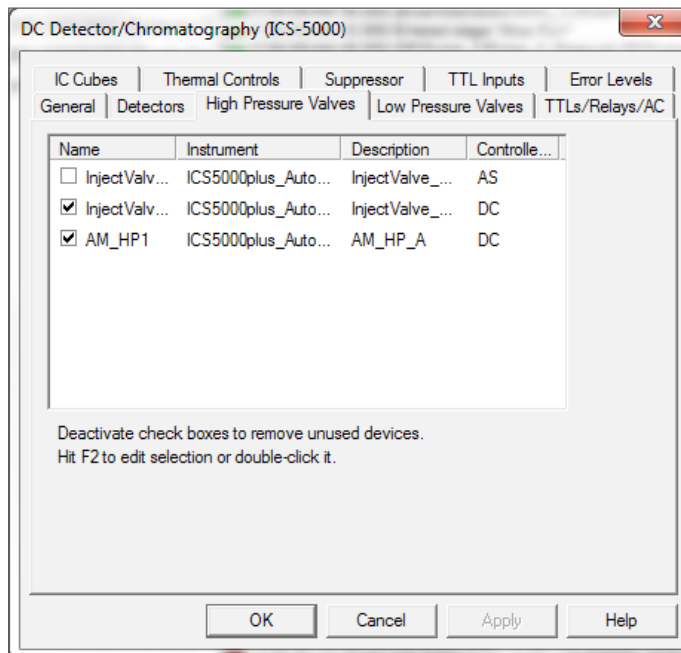

Figure 4. Assign control of high pressure valves to DC.

Dionex AS-HV autosampler

Select the Internal Peristaltic pump in Pull mode for the lowest background levels. The serial communication typically occurs on COM 7 (Figure 5).

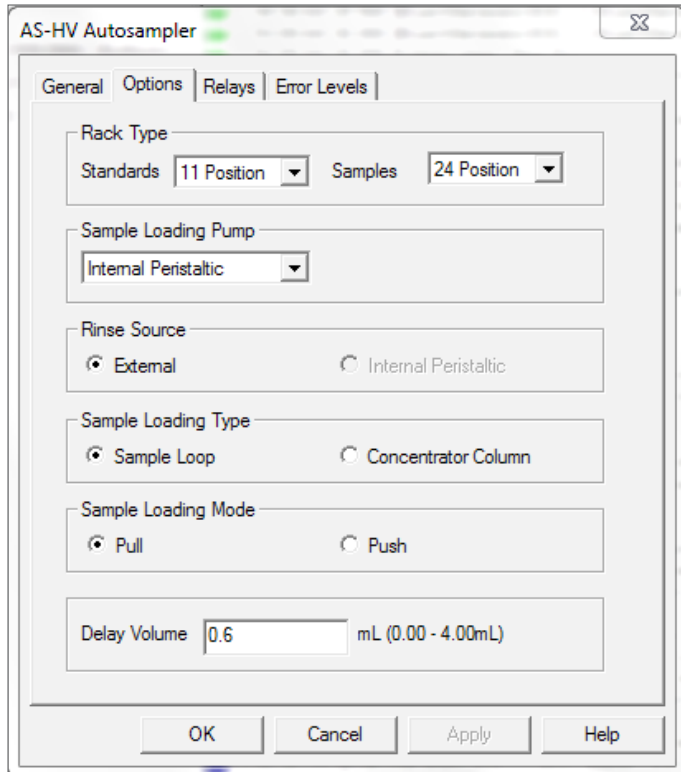
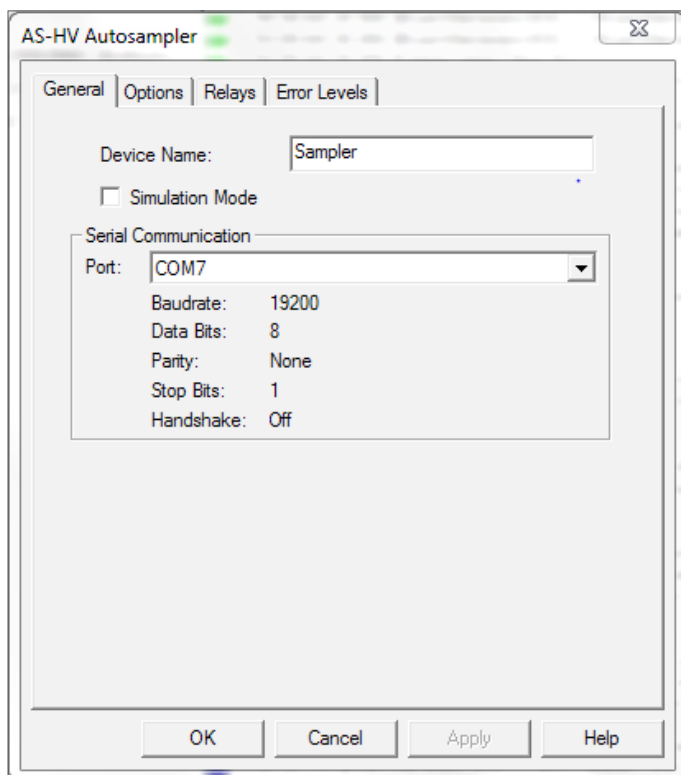

Figure 5. Configuring the high-volume autosampler.

Plumbing the Dionex ICS-5000+ HPIC system

Installing and Conditioning the IC consumables:

- Complete the IC system plumbing according to Figure 1
- Install and condition the eluent generator cartridge and the trap column according to the Quick Start instructions and instrument and module manuals⁹⁻¹⁸
- Install the HP Degas module and backpressure tubing
- Install the concentrator column and condition for 10 min with the flow temporarily directed to waste
- Install and condition the guard and analytical columns according to the Quality Assurance Report conditions for 20 min with the flow temporarily directed to waste
- Condition and install the suppressor according to the QuickStart and instrument instructions

The optimum system backpressure is 2000 to 3500 psi for an HPIC Reagent-Free system using eluent generation. If the system pressure is below 2000 psi, add a yellow PEEK (0.003 in i.d., 0.076 mm i.d.) backpressure coil between the HP Degas module and the injection valve. For this technical note, an additional 1000 psi backpressure loop was added.

Installing the Dionex RFC-10 Reagent-Free Controller and the Dionex Electrolytic Water Purifier modules

The Dionex EWP Electrolytic Water Purifier module, much like the electrolytic suppressor, requires a constant current supply to power the device. The Dionex ICS-5000+ HPIC system is a dual system with dual suppressor power ports. However, the extra suppressor port is typically needed for the suppressor of the second application run on the IC system. In this approach, an external power source was used. The suppressor channel of the Dionex RFC-10 module powers the Dionex EWP Electrolytic Water Purifier module. The Dionex RFC-10 is connected to the DP pump by a TTL cable on Relay 2 position (previously mentioned in Figure 3). This approach of using an external power source allows the second system of the Dionex ICS-5000+ IC to be used for another application. Assemble the TTL cable and install the Dionex Reagent-Free Module according to Table 4 and Figures 6–8.

Table 4. Installing the Dionex Reagent-Free module.

Type	Action	Description
Power	Connect power cable	Power
TTL Control	Press the TTL Control button on the back of the Dionex RFC-10 until it is the “out” position (Figure 6)	Allows TTL to control the module
TTL Cable: Red-and-Black Twisted Wire with 2-pin and 25-pin connectors	Dionex RFC-10 connection: Connect the black wire to left position and the red wire to right position on the 2-pin connector	Connects one end of the TTL cable to the Dionex RFC-10 module
	Dionex RFC-10 connection: Install the 2-pin connector to Output on the back of the module (Figure 6)	
	DP Pump connection: Connect the red wire to Position 8 and the black wire to Position 20 in the DP Module 25-pin connector (Figure 7A)	Connects the second end of the TTL cable to the 25-pin connector
	Assemble connector	
	DP Pump connection: Insert the DP Module 25-pin connector into the Digital I/O Port on the back of the Dionex ICS-5000+ DP module (Figure 7B)	Connects the assembled connector-TTL cable to the DP Pump module, allowing the Dionex EWP Electrolytic Water Purifier module via the Dionex RFC-10 module to turn off and on, in cinque with the DP Pump 1
AES/ASRS suppressor cable	Connect to EWP Electrolytic Water Purifier module (Figure 6)	The Dionex RFC-10 provides the power and controls the EWP Electrolytic Water Purifier module (Figure 8)

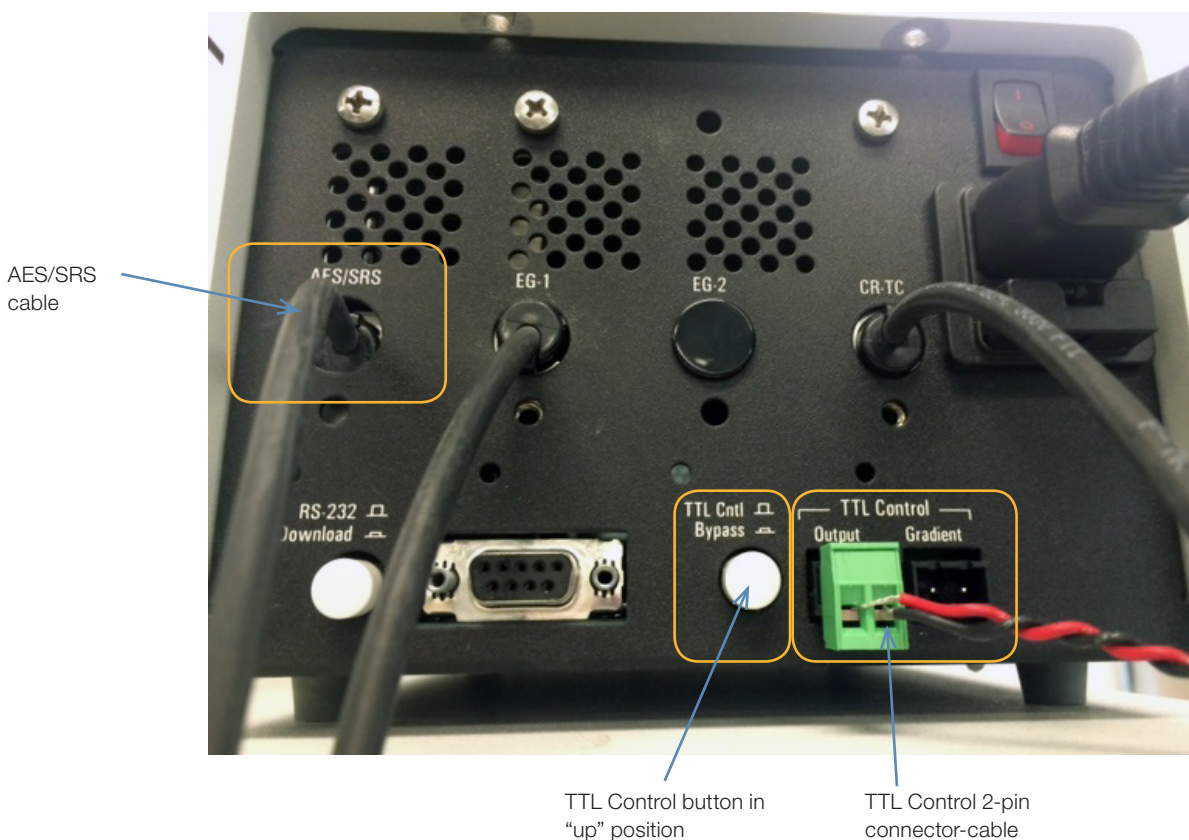
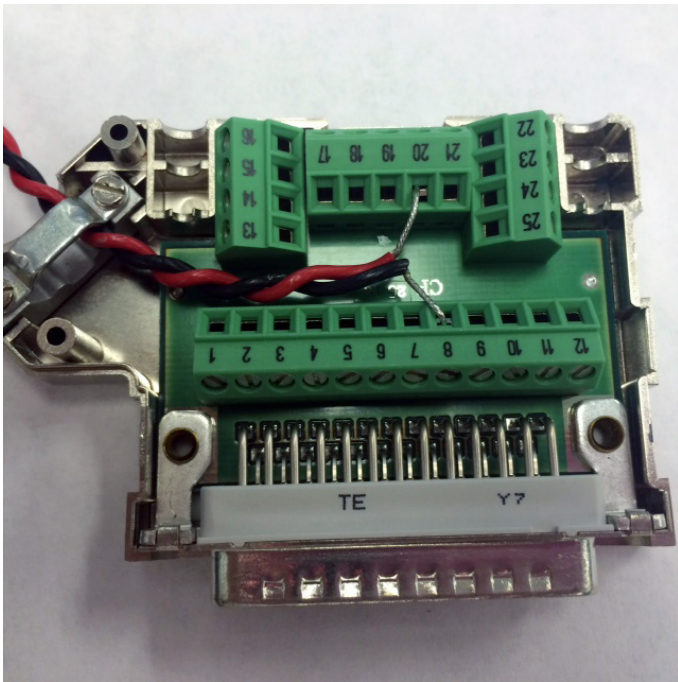
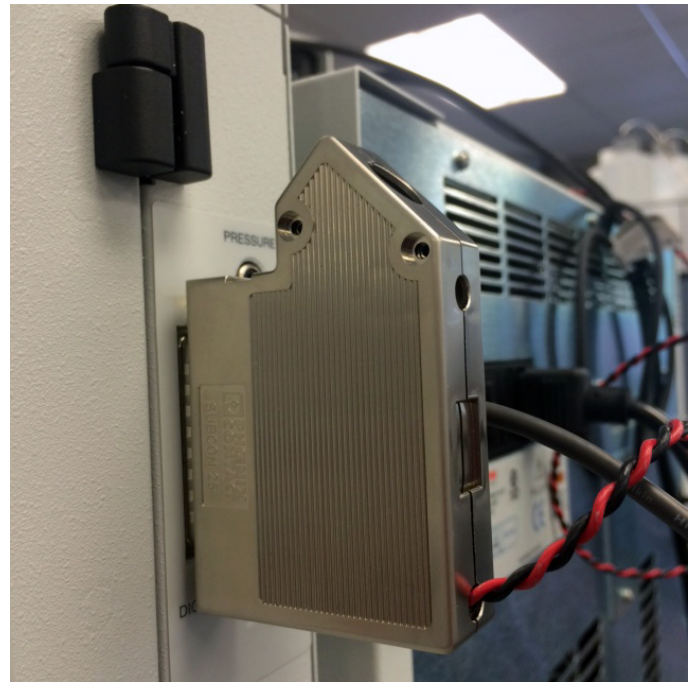

Figure 6. TTL control on Dionex RFC-10 module.



7A: Assemble the 25-pin connector with the TTL cable: red wire in position 20; black wire in position 8.

Figure 7. Assembling and connecting the TTL cable connectors.



7B: Install the 25-pin connector on the back of Dionex ICS-5000+ DP module.

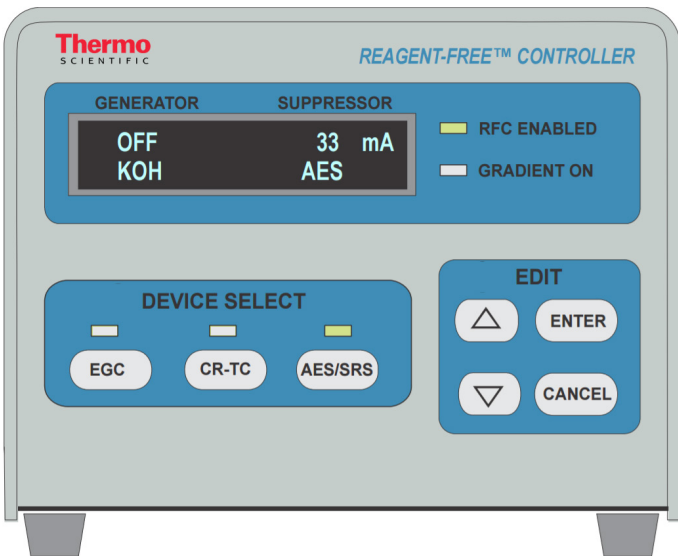

Figure 8. Reagent-Free controller RFC-10 module used to supply 20 mA of current to Dionex EWP Electrolytic Water Purifier module.

Programming the Dionex Reagent-Free RFC-10 module

The Dionex RFC-10 can be programmed to power the Dionex EWP Electrolytic Water Purifier module and other devices. To program the module to deliver 20 mA to the Dionex EWP Electrolytic Water Purifier, select the suppressor channel, type, and current:

- Select AES suppressor type by pressing the Arrow key on the module to advance to the suppressor type screen and press the Enter key to save the selection
- Program 20 mA current by pressing the Arrow key incrementally to “20”, press the Enter key to save the commands
- Advance to the Main Screen (Figure 8) by pressing the Arrow key. Notice that the mA should read 20.00 when the pump is on

Table 5. Plumbing the Dionex EWP Electrolytic Water Purifier.

Port	Incoming Line	Function
1	From CD Eluent Out	Removes ionic contamination
2	From Port W of 6-port Injection valve	Provides water source to create clean Regen Water
3	From CR-ATC 500 Regen Out Line	Cleans Regen Water
Port	Outgoing Line	Function
4	Connect to 10-Port valve, Port 6	Delivers clean water as a carrier to transfer large loop to concentrator
5	Connect to Suppressor Regen ports and then CRD, CR-ATC 500 Regen lines in series	Delivers clean water for regenerant channels of suppressor, then CRD 300, and CR-ATC 500 trap column
6	Direct to waste	Sends cleaned Regenerant Out water to waste

Dionex EWP Electrolytic Water Purifier

The Dionex EWP Electrolytic Water Purifier (Figure 9) cleans the anionic contamination from the eluent stream to provide a clean source of carrier water and regenerant water. The result is a lower level of background contamination. The flow path in the Dionex EWP Electrolytic Water Purifier is from Port 1 to Port 4; Port 2 to Port 5; and Port 3 to Port 6. Install the Dionex EWP Electrolytic Water Purifier according to Table 5.

Plumbing the Dionex AS-HV autosampler

The Dionex AS-HV Autosampler is a high-volume autosampler designed for trace ion applications. This autosampler is a low-pressure autosampler, therefore samples are loaded into a sample loop and then the sample is transferred to a concentrator column. Plumb the Dionex AS-HV Autosampler in Pull mode through the waste and sampler ports in the Dionex AutoPrep valve (Dionex Automation Manager AM-HP1 10-port valve) according to Figure 1, Table 6, and the autosampler Operator’s Manual.⁹

The Dionex AS-HV Autosampler uses a peristaltic pump (Dionex AS-HV Rinse Pump) to push or pull samples by compressing flexible tubing. This flexible tubing will need to be examined every week to ensure that it is still flexible. A typical replacement cycle is every month. The flexible tubing can be a source of contamination when plumbed in “push” mode. However as shown here in Pull mode, the sample flows through the peristaltic tubing after filling the sample loop, and therefore does not contribute to baseline contamination.

Set the autosampler flow rate to ~3.5 mL/min by adjusting the Rinse Pump Speed knob. To measure the flow rate, collect the wastewater from the autosampler into a 25 mL graduated cylinder for 5 min. Adjust the Rinse Pump Speed knob accordingly until the flow rate is ~3.5 mL/min.

Plumbing the Dionex AutoPrep system module and calibrating the loop ratio

The Dionex AutoPrep system module loads multiple 10 µL aliquots of a 50 ppb standard onto the concentrator column. The standard solution can be prepared at 1000× the calibration concentrations because the small loop/large loop ratio (10 µL/10 mL) is 1/1000×, which acts as 1000× dilution. Using a 1000× higher concentration standard for these calibrations minimizes the effects of environmental contamination and inaccurate manual dilutions.

Install the Dionex AutoPrep system large loop and small loops into the AM-HP 10-port valve (Table 6).

Large loop to small loop ratio

Bromide was used to determine the Dionex AutoPrep system large loop to small loop ratio (ppt concentrations). Bromide was selected for the loop calibrations because it is not typically found as an airborne environmental contaminant, and therefore would not be compromised during calibration. The small Dionex AutoPrep loop is approximately 10 µL, whereas the large loop is 10 mL.

Use the freshly prepared 5 ppb bromide working standard. Concentrate 10 mL of the working standard by overflowing the Dionex AutoPrep system large loop with ~12 mL total volume. Then concentrate 10 µL in the Dionex AutoPrep system small loop by overflowing 10x. Record the peak area responses. Repeat both measurements in triplicate. Determine the ratio by comparing the average peak area response for each loop. Add the factor in the dilution factor column in the sequence.

10-Port Automation Manager valve

The devices plumbed to and from the 10-port Automation Manager valve are summarized in Table 6.

Table 6. Plumbing the 10-Port AM-HP1 Automation Manager valve.

Valve Position	Plumbed Device
1	To Dionex CRD 300, and then Port "S" and Concentrator on 6-Port Injection Valve
2	Dionex AutoPrep system large loop
3	From Dionex AS-HV Autosampler
4	To waste
5	Dionex AutoPrep system large loop
6	From Dionex EWP Electrolytic Water Purifier, Port 4
7	Dionex AutoPrep system small loop
8	To waste
9	From standard
10	Dionex AutoPrep system small loop

Creating instrument programs with the Dionex AutoPrep system

Dionex AutoPrep system templates can be downloaded:

1. Download the datasource and user-defined columns.
2. Follow the Dionex AutoPrep system Installation Instructions.
3. Mount the Dionex AutoPrep system datasource listed in the Chromeleon CDS software DVD. Import the Dionex AutoPrep system user-defined columns into the local datasource (refer to the Dionex AutoPrep system Installation Instructions for details).
4. Copy the Dionex AutoPrep system template files to the local datasource.

The Dionex AutoPrep system methods can also be created using the Chromeleon Wizard for a basic method. The Chromeleon Wizard will also insert the commands needed for switching the valves to load standards through the small loop and samples through the large loop.

To create a new instrument method using the Chromeleon Wizard:

1. Select Create, Instrument Method, and select Instrument.
2. Enter the values from the Chromatographic Conditions section.
3. Save the instrument method.

This provides a basic instrument method that will be used to create a separate instrument method for samples, and for each of the calibration standards. Enter "1000" into the dilution factor column in the sequence temporarily until the ratio of the two Dionex AutoPrep system loops are determined.

Creating instrument programs for calibration standards

The calibration curve is created by loading aliquots of the standard from the Dionex AutoPrep system small loop, one aliquot for Calibration Standard 1, two for Calibration Standard 2, etc., onto the concentrator column and eluting the concentrated standard onto the guard and separation columns at injection. Therefore, a separate instrument program must be created for each calibration standard.

Program time to fill 10 µL loop

To determine the amount of time needed to fill and overflow the small sample loop, first measure the flow rate as described in the standard preparation section. A minimum of 3x overflow should be used. In this case we use a 10x overflow for the standard.

To calculate the time needed to fill the 10 µL loop (small loop volume):
Time (min) = standard loop (µL) × 10 (overflow) / flow rate (µL/min)
Example: time = (10 × 10) / 500 = 0.2 min

The calculation above shows that 0.2 min is sufficient to overflow the small loop 10x. This time is transferred into the program. Tables 7 and 8 and Figures 9 and 10 illustrate this process. Table 7 summarizes the commands needed to load and concentrate a single aliquot of the 50 ppb standard (Calibration Standard 1, 50 ng/L (ppt)). Name this instrument program Calibration Standard 1. Figure 9 shows the script of the instrument program for Calibration Standard 1.

Table 7. Timing for loading, concentrating, and injecting a single standard aliquot.

Timing (min)*	Valve	Position	Command
-11.5	Inject Valve	Load	DC.InjectValve_2.LoadPosition
-10.5	AM_HP1	B	DC.AM_HP1.B
-10.3	AM_HP1	A	DC.AM_HP1.A
0	AM_HP1	B	DC.AM_HP1.B
	Inject Valve	Inject	DC.InjectValve_2.InjectPosition

▲ -11.500	Equilibration	Duration = 11.500 [min]	
▲ -11.500			
	DC.InjectValve_2.LoadPosition		
	EluentGenerator.EGC_1.Concentration	50.00 [mM]	
▲ -10.500			
	DC.AM_HP1.B		
▲ -10.300			
	DC.AM_HP1.A		
▲ -7.000			
	EluentGenerator.EGC_1.Concentration	50.00 [mM]	
	EluentGenerator.EGC_1.Concentration	1.00 [mM]	
▲ 0.000	Inject		
	DC.AM_HP1.B		
	DC.InjectValve_2.InjectPosition		Inject
▲ 0.000	Start Run		
	DP.Pump_2.Pump_2_Pressure.AcqOn		
	CDet1.Autozero		
	CDet1.CD_1.AcqOn		
	CDet1.CD_1_Total.AcqOn		
▲ 0.000	Run	Duration = 30.000 [min]	
	DC.AM_HP1.A		
	EluentGenerator.EGC_1.Concentration	1.00 [mM]	
▲ 3.000			
	DC.AM_HP1.B		EWP going through large loop, washing loop

Figure 9. Dionex AutoPrep system section of instrument program for Calibration Standard 1.

Table 8. Timing for loading, concentrating, and injecting four standard aliquot.

Timing (min)	Valve	Position	Loading 10 µL of Standard	Command
-11.5	Inject Valve	Load		DC.InjectValve_2.LoadPosition
-10.5	AM_HP1	B	1x	DC.AM_HP1.B
-10.3	AM_HP1	A		DC.AM_HP1.A
-10.1	AM_HP1	B	2x	DC.AM_HP1.B
-9.9	AM_HP1	A		DC.AM_HP1.A
-9.7	AM_HP1	B	3x	DC.AM_HP1.B
-9.5	AM_HP1	A		DC.AM_HP1.A
-9.3	AM_HP1	B	4x	DC.AM_HP1.B
-9.1	AM_HP1	A		DC.AM_HP1.A
0.0	AM_HP1	B		DC.AM_HP1.B
	Inject Valve	Inject		DC.InjectValve_2.InjectPosition

Table 8 summarizes the commands needed to load and concentrate four aliquots of the 50 ppb standard (Calibration Standard 4, 200 ppt). These commands can be inserted into the script of the program (Insert time, insert command). Save this instrument program

as Calibration Standard 4. Create instrument programs for Calibration Standards 2, 3, and 5 in a similar way. Figure 10 shows the script of the instrument program for Calibration Standard 4, using four aliquots concentrated on the concentrator column prior to injection.

▲ -11.500	Equilibration	Duration = 11.500 [min]	
▲ -11.500			
	DC.InjectValve_2.LoadPosition		
	EluentGenerator.EGC_1.Concentration	50.00 [mM]	
▲ -10.500			
	DC.AM_HP1.B		first 10 uL
▲ -10.300			
	DC.AM_HP1.A		
▲ -10.100			
	DC.AM_HP1.B		second 10 uL
▲ -9.900			
	DC.AM_HP1.A		
▲ -9.700			
	DC.AM_HP1.B		third 10uL
▲ -9.500			
	DC.AM_HP1.A		
▲ -9.300			
	DC.AM_HP1.B		fourth
▲ -9.100			
	DC.AM_HP1.A		
▲ -7.000			
	EluentGenerator.EGC_1.Concentration	50.00 [mM]	
	EluentGenerator.EGC_1.Concentration	1.00 [mM]	
▲ 0.000	Inject		
	DC.AM_HP1.B		
	DC.InjectValve_2.InjectPosition		inject
▲ 0.000	Start Run		
	DP.Pump_2.Pump_2_Pressure.AcqOn		
	CDet1.Autozero		
	CDet1.CD_1.AcqOn		
	CDet1.CD_1_Total.AcqOn		
▲ 0.000	Run	Duration = 30.000 [min]	
	DC.AM_HP1.A		
	EluentGenerator.EGC_1.Concentration	1.00 [mM]	
▲ 3.000			
	DC.AM_HP1.B		EWP going through large loop, washing loop

Figure 10. Dionex AutoPrep system section of instrument program for Calibration Standard 4.

Table 9. Autosampler and valve timing for loading, concentrating, and injecting 10 mL samples.

Timing (min)	Valve	Command	Value
-21.5	AM_HP1	DC.AM_HP1.A	A position
-21.5	AS-HV Autosampler	Sampler.Position	system.injection._Position
		Sampler.GotoPosition	
		Sampler.NeedleDown	
-21.4		Sampler.InternalPumpOn	Starts sample loading into large loop
-11.5		Sampler.InternalPumpOff	
	Injection Valve	DC.InjectValve_2.LoadPosition	Places injection valve in load
	AM_HP1	DC.AM_HP1.B	B position
-11.0	AS-HV Autosampler	Sampler.Rinse	Rinses
-9.0		Sampler.InternalPumpOff	Turns peristaltic pump off
	AM_HP1	DC.AM_HP1.A	
0.0	AM_HP1	DC.AM_HP1.B	
	Inject Valve	DC.InjectValve_2.InjectPosition	Concentrated sample elutes onto guard and separation columns
3.0	AM_HP1	DC.AM_HP1.B	Washing large loop

▲ -21.500	Equilibration	Duration = 21.500 [min]	
▲ -21.500	DC.AM_HP1.A		Preparing large loop for sample loading; EWP going through small loop
	EluentGenerator.EGC_1.Concentration	50	
▲ -21.500	Sampler.Position	system.injection._Position	
	Sampler.GotoPosition		
	Sampler.NeedleDown		
▲ -21.400	Sampler.InternalPumpOn		
▲ -15.000	EluentGenerator.EGC_1.Concentration	50.00 [mM]	
	EluentGenerator.EGC_1.Concentration	1.00 [mM]	
▲ -11.500	Sampler.InternalPumpOff		
	DC.InjectValve_2.LoadPosition		
	DC.AM_HP1.B		EWP going through large loop onto conc column
▲ -11.000	Sampler.Rinse		
▲ -9.000	Sampler.InternalPumpOff		
▲ 0.000	Inject		
	DC.AM_HP1.A		injecting from conc- column, EWP going through small loop
	DC.InjectValve_2.InjectPosition		inject
▲ 0.000	Start Run		
	DP.Pump_2.Pump_2_Pressure.AcqOn		
	CDet1.Autozero		
	CDet1.CD_1.AcqOn		
	CDet1.CD_1_Total.AcqOn		
	Sampler.Rinse		
▲ 0.000	Run	Duration = 30.000 [min]	
	DC.AM_HP1.A		
	EluentGenerator.EGC_1.Concentration	1.00 [mM]	
▲ 3.000	DC.AM_HP1.B		EWP going through large loop, washing loop

Figure 11. Dionex AutoPrep system section of instrument program for sample analysis.

Creating instrument programs for analysis of samples and check standards

A separate instrument program is needed for the sample analysis. For sample analysis, the Dionex AS-HV autosampler loads ~3× of the 10 mL of the sample in Pull Mode to overfill the 10 mL Dionex AutoPrep system large loop. The Dionex EWP Electrolytic Water Purifier transfers the sample from the large loop, through the Dionex CRD-300 device to remove the carbonate, and onto the concentrator column. At injection, the concentrated sample is eluted from the concentrator onto the guard and separation columns. This process is facilitated by manual commands of the Dionex AS-HV autosampler, and the Automation Manager and Injection valves (Table 9, Figure 11).

Results and discussion

Determinations of trace anions (ppb to ppt) in ultrapure water are important to the power and the electronics industries to prevent corrosion failures as a result of anionic contamination. Consequently, the ASTM International limits ionic contamination to ppt concentrations, per the ASTM D 5127.¹⁸ However, trace anion determinations can prove to be challenging. Water samples easily absorb contaminants from the environment, including the air and the instrument itself. As a result, these samples may provide misleading results. In some cases, the contamination may be higher than the analyte concentrations.

In this technical note, determinations of anions at ppt concentrations were achieved using the Dionex AutoPrep system and EWP Electrolytic Water Purifier modules on one system of the Dionex ICS-5000+ dual HPIC system. This approach increases the sensitivity and reduces the baseline contamination of the analysis, as previously demonstrated on the Thermo Scientific™ Dionex™ Integriion™ HPIC™ system.^{7,8} This configuration allows the second system to be used for another application.

In this technical note, ppt concentrations of trace anions in samples were determined by loading a large sample volume (10 mL sample) by the Dionex AS-HV autosampler in pull mode into the Dionex AutoPrep system large loop. The sample is transferred by the Dionex EWP Electrolytic Water Purifier-purified water to and degassed inline by the Dionex CRD 300 device, and concentrated on the Dionex IonPac UTAC-LP2 concentrator column.

The concentrated anions were eluted and separated at 1.0 mL/min using an electrolytically generated KOH gradient on the Dionex IonPac AS17-C anion-exchange column. The gradient allows optimizing the method for the optimum elution of each analyte, resulting in symmetrical small width peaks that increase reproducibility and consistent peak integration.

Combined with suppressed conductivity, baseline conductivity well below 1 µS was achieved, increasing sensitivity. All seven anions were eluted within 30 min and detected by suppressed conductivity detection. However, the column wash, equilibration, and loading times can include an additional 12–22 min per standard or sample analysis.

When performing trace analysis, it is advantageous to both increase sensitivity and decrease the baseline contamination. Typically sensitivity is accomplished by injecting a large volume of sample or concentrating a larger volume of sample (10 mL), as shown here. Reducing baseline contamination is often the most challenging aspect of trace analysis.

The carbonate peak is typically the largest peak in trace anion determinations. Ideally, carbonate should be removed prior to concentration to minimize poor chromatography from carbonate acting as an eluent on the concentrator column. The following techniques previously demonstrated in TN 177⁷ were also used here to reduce baseline contamination:

- Selecting a separation column optimized for trace anion determinations with low residual sulfate, such as the Dionex IonPac AS17-C column
- Selecting a suitable gradient that results in low baseline drift (<100 nS/cm per min)
- Using the Dionex EWP Electrolytic Water Purifier as a closed-loop system of purified water for the transfer water and to supply the regenerant for the electrolytic devices
- Preparing working standards inline using the Dionex AutoPrep system small loop (1000× smaller injection than the samples) from the manually prepared 50 ppb stock standard resulting in an apparent 50 ppt standard
- Using incremental additions of the standard solution to create the calibration curve

- Operating the Dionex AS-HV Autosampler in Pull Mode
- Removing carbonate using the Dionex CRD 300 Carbonate Removal Device prior to concentrating the sample

In addition to using the common trace analysis techniques of large volume and concentration, this method also uses the Dionex AutoPrep system module to proportionally load 1000x higher volume for samples than for the calibration standard. The total mass-on-column is effectively 1000x less for the standard than for the sample. For example, in this technical note, 10 μ L aliquots of 50 ppb standard result in aliquots of 50 ppt concentration as compared to the sample.

Baseline contamination

As previously mentioned, reducing and maintaining stable baseline contamination levels is challenging. Figure 12 shows the baseline contamination levels obtained in our lab (community lab without cleanroom conditions). The blanks are:

- A system blank with Dionex EWP Electrolytic Water Purifier-generated water, concentrated and injected (Chromatogram A)
- A deionized water blank from a pre-cleaned container (Chromatogram B)
- A 50 ppt standard is shown for comparison (Chromatogram C)

Carbonate is present as the dominant peak (Peak 8). Contamination, likely related to acrylate, was observed in Peak 3 but diminished over the experimental period. The contamination is also present in the standards, shown in Figures 13 and 14, at approximately the same concentration, indicating the contamination is not related to sample concentrating or loading.

To determine linearity, one to five 10 μ L aliquots of the 50 ppb working standard were incrementally loaded into the Dionex AutoPrep system small loop, concentrated, and separated according to the method conditions (Figure 13). The seven anions at 50 ppt apparent concentration elute within 30 min, exhibit good chromatography and response, and have good asymmetry and narrow peak width (Figure 13).

The calibration results of five replicate injections, from 50 ppt to 250 ppt, showed good linear peak responses to concentration, with coefficients of determination (r^2) greater than 0.99 (fluoride: 0.9991; chloride: 0.9990; nitrite: 0.9989; bromide: 0.9992, sulfate: 0.9990, phosphate: 0.0.9973). The calibration plots for chloride and sulfate are shown in Figure 14. The calibration plots for nitrite, nitrate, bromide, and phosphate (not shown) were similar.

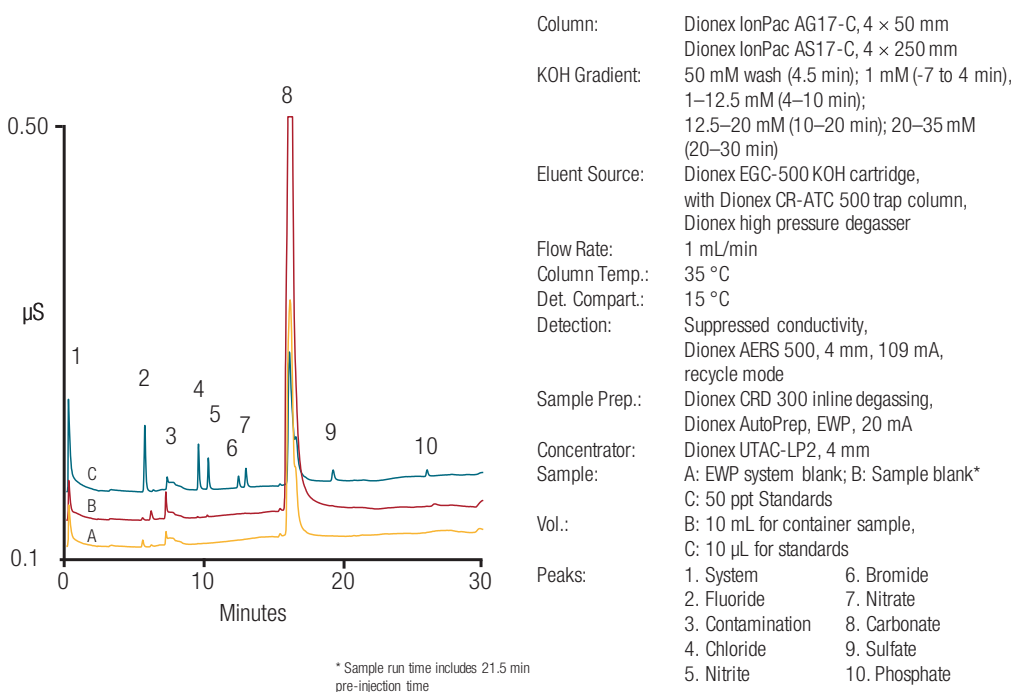
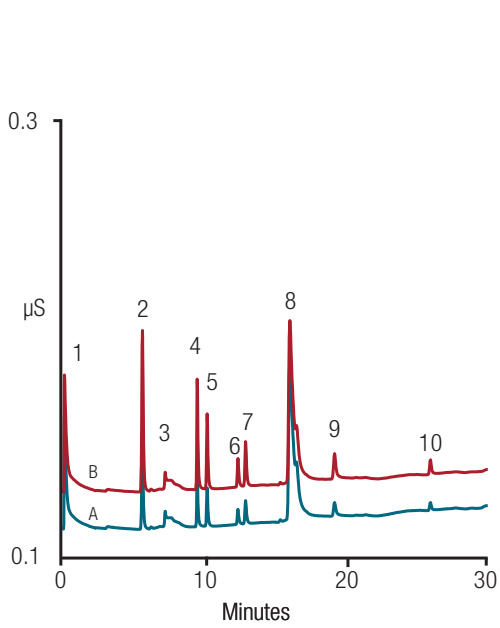

Figure 12. Comparison of Dionex EWP Electrolytic Water Purifier water and container blanks with 50 ppt trace anions using Dionex AutoPrep system small loop.



Column: Dionex IonPac AG17-C, 4 × 50 mm
 Dionex IonPac AS17-C, 4 × 250 mm
 KOH Gradient: 50 mM wash (4.5 min); 1 mM (-7 to 4 min),
 1–12.5 mM (4–10 min); 12.5–20 mM (10–20 min); 20–35 mM
 (20–30 min)
 Eluent Source: Dionex EGC-500 KOH cartridge,
 with Dionex CR-ATC 500 trap column,
 Dionex high pressure degasser
 Flow Rate: 1 mL/min
 Column Temp.: 35 °C
 Det. Compart.: 15 °C
 Detection: Suppressed conductivity,
 Dionex AERS 500, 4 mm, 109 mA,
 recycle mode
 Sample Prep.: Dionex CRD 300 inline degassing,
 Dionex AutoPrep, EWP, 20 mA
 Concentrator: Dionex UTAC-LP2, 4 mm
 Standards: A: 50 ppt B: 100 ppt
 Vol.: 10, 20 µL in AutoPrep Small Loop
 Peaks: 1. System 6. Bromide
 2. Fluoride 7. Nitrate
 3. Contamination 8. Carbonate
 4. Chloride 9. Sulfate
 5. Nitrite 10. Phosphate

Figure 13. 50 ppt and 100 ppt trace anion standards in ultrapure water using the Dionex AutoPrep system small loop.

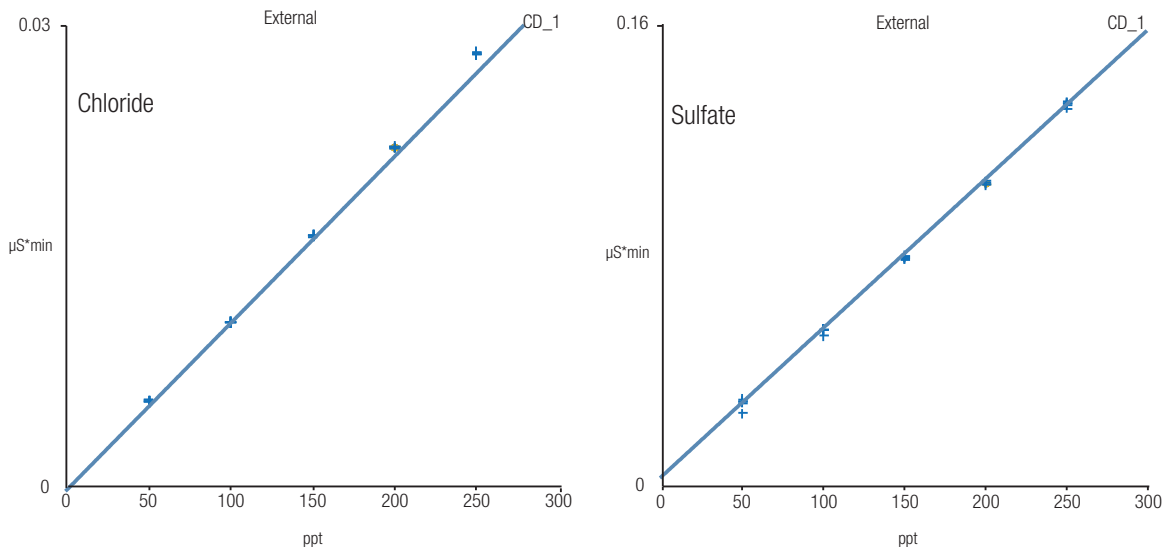

Figure 14. Calibration plots for chloride (left) and sulfate (right).

Sensitivity, method detection limits

The system contamination levels, without an injection and using the Dionex EWP Electrolytic Water Purifier water were very low, however, sampling 10 mL of DI water continued to be challenging. Therefore, the method detection limits (MDL) were determined using 3× S/N above the contamination levels measured in lab DI water in sample containers. For analytes not present in the sample containers, the MDL was estimated using 3× S/N of the 50 ppt standard. The MDL results ranging from single to double digit ppt are summarized in Table 10 based on 1 nS peak to peak noise per min.

Table 10. Estimated method detection limits.

Analyte	Standard (ppt)	Limit of Detection, 3× S/N (ppt)
Fluoride	8.6*	26
Chloride	6.5*	20
Nitrite	8.0*	24
Bromide	50.0**	7
Nitrate	6.2*	19
Sulfate	51.7**	19
Phosphate	53.1**	43

* Estimated concentration in sample containers of a 10 mL sample injection

** Calibration standard 50 ppt

Conclusion

This technical note demonstrates how the combination of RFIC-EG and Dionex AutoPrep systems minimizes the time and labor needed for sensitive determinations of anions in ultrahigh purity water as required by ASTM D5127. The Dionex AutoPrep system application is used to calibrate the method and automate sample delivery in a closed system that minimizes sample contamination. In addition, this technical note describes the installation and configuration of the Dionex ICS-5000+ HPIC system with the Dionex AutoPrep system and Dionex EWP Electrolytic Water Purifier for trace anion determinations.

The resulting combination provides low backgrounds and single-digit ppt detection limits using a gradient separation. The system represents a cost-effective solution for the ultratrace analysis of anions. Determination of anions at these levels is necessary to characterize impurities in the ultrahigh purity water produced by the semiconductor and power industries. Further information on this technical note and other application documents can be found in the online interactive Thermo Scientific™ AppsLab Library of Analytical Applications at <https://appslab.thermofisher.com>.¹⁹

References

1. Thermo Scientific Application Note 114: *Determination of Trace Anions in High-Purity Waters Using Direct Injection and Two-Step Isocratic Ion Chromatography*, Sunnyvale, CA, February 1997.
2. Thermo Scientific Application Note 85: *Determination of Trace Anions in Organic Solvents*, Sunnyvale, CA, June 2000.
3. Thermo Scientific Application Update 142: *Improved Determination of Trace Anions in High Purity Waters by High-Volume Direct Injection with the EG40*, Sunnyvale, CA, 2001.
4. Thermo Scientific Application Note 153: *Monitoring for Trace Anion Contamination in the Extracts of Electronic Components*, Sunnyvale, CA, 2003.
5. Thermo Scientific Application Brief 106: *Trace Anion Analysis Using an ICS-2100 System with RFIC-ESP and an Electrolytic Water Purifier*, Sunnyvale, CA, October 2009.
6. Thermo Scientific Application Brief 125: *Determination of Trace Levels of Inorganic Anions in High-Purity Water Using Capillary Ion Chromatography*, AB70458_E 1/13S, Sunnyvale, CA 2012.
7. Thermo Scientific Technical Note 177: *Configuring the Dionex Integrion HPIC System for Trace Anion Determinations in Ultrapure Water*, Sunnyvale, CA, June 2016.
8. Thermo Scientific Product Spotlight: *Dionex Integrion HPIC System Enhancing Automated Sample Preparation for Trace Determinations*. Sunnyvale, CA. [Online] <https://tools.thermofisher.com/content/sfs/brochures/SP-71785-IC-Integrion-Sample-Prep-Trace-Determinations-SP71785-EN.pdf> (accessed October 27, 2016).
9. Thermo Fisher Scientific. *Dionex AS-HV Operator's Manual*. Doc. Document No. 065259, Sunnyvale, CA, 2012.
10. Thermo Fisher Scientific. *Dionex ICS-5000+ Ion Chromatography System Installation Instructions manual*. Dionex Document No. 065447, Sunnyvale, CA. Uploaded February 2016.
11. Thermo Fisher Scientific. *Dionex ICS-5000+ Ion Chromatography System Operator's Manual*. Document No. 065446. Sunnyvale, CA. Uploaded February 2016.

12. Thermo Fisher Scientific. Dionex Reagent-Free Controller Operator's Manual. Document No. 031880. Sunnyvale, CA. Uploaded February 2016.
13. Thermo Fisher Scientific. Dionex Reagent-Free Controller Getting Started Guide. Document No. 031895. Sunnyvale, CA. Uploaded February 2016.
14. Thermo Fisher Scientific. Dionex Product Manual for Eluent Generator Cartridges. P/N: 065018-05, Sunnyvale, CA, June 2014.
15. Thermo Fisher Scientific. Dionex Product Manual for the Continuously Regenerated Trap Column (CR-TC). P/N: 065018-05, Sunnyvale, CA, November 2012.
16. Thermo Fisher Scientific. Dionex ERS 500 Suppressor Product Manual. P/N: 031956-09, Sunnyvale, CA, November 2013.
17. Thermo Fisher Scientific. IonPac AS17-C Column Product manual. Document No. 065259, Sunnyvale, CA, August 2008.
18. ASTM Specification D 5127, ASTM International. 100 Barr Harbor Drive, West Conshohocken, PA 19428
19. Thermo Scientific AppsLab Library of Analytical Applications. <https://appslab.thermofisher.com/>

Find out more at www.thermofisher.com/chromatography