

Determination of sugars in foods using HPAE-PAD in dual eluent generation cartridge mode

Authors: Jingli Hu and Jeffrey Rohrer
Thermo Fisher Scientific, Sunnyvale, CA

Keywords: Dionex CarboPac PA20-1 mm column, Dionex ICS-6000 HPIC system, electrochemical detection, Dual EGC Mode, carbohydrates

Goal

To demonstrate that AOAC 2018.16, a first action method for sugars determination in foods, can be executed with a Thermo Scientific™ Dionex™ CarboPac™ PA20-1 mm column using KOH/KMSA eluent produced electrolytically using Dual Eluent Generation Cartridge (Dual EGC) mode

Introduction

Numerous methods have been used routinely for the determination of sugars in food products. Enzymatic techniques are fast but indirect methods that use the chosen enzyme to convert saccharides to compounds that can be measured easily.¹ Enzyme-based techniques also lack specificity and cannot determine all sugars simultaneously. HPLC can be used for the determination of sugars in foods. However, only nonselective detection techniques, such as refractive index (RI), evaporative light scattering, and charged aerosol, are available due to carbohydrates lacking a UV or fluorescent active functional group. The quantification of sugars is affected by the numerous interferences in complex food samples. In addition, mobile phase gradients cannot be used with



RI detection because of the resulting large changes in the baseline. This limits the number of sugars that can be separated in complex samples. GC methods have also been used for sugar profile analysis. However, GC involves derivatization of sugars, and the separation of the derivatized sugars is inadequate.² High-performance anion-exchange chromatography (HPAE) with pulsed amperometric detection (PAD) is a well-established technique for carbohydrate analysis. HPAE-PAD is a direct-detection technique and therefore eliminates errors associated with analyte derivatization. It is also a high-resolution separation technique that allows the resolution of a large number of sugars in a single injection.

The determination of nutritionally relevant carbohydrates, including galactose, glucose, fructose, sucrose, lactose, and maltose, in foods was described in the AOAC 2018.16 First Action Method.³ The method uses HPAE-PAD with manually prepared sodium hydroxide eluents.

In this application note, the AOAC 2018.16 First Action Method was modified to Dual EGC mode conditions using a Dionex CarboPac PA20-1 mm column. The 1 mm column requires a flow rate about nine times lower than the 3 mm column, significantly reducing eluent consumption. Dual EGC mode operation avoids the manual preparation of the sodium hydroxide/sodium acetate eluents. This mode uses a methanesulfonic acid (MSA) eluent generation cartridge (EGC) and a potassium hydroxide (KOH) EGC in series to generate an extremely reproducible and accurate KOH/KMSA eluent gradient. Key performance parameters were evaluated, including separation, calibration, limits of detection, accuracy, and precision. The sugars in three food samples were determined using this Dual EGC Mode-based HPAE-PAD method.

Experimental

Equipment

- Thermo Scientific™ Dionex™ ICS-6000 HPIC system including:
 - Thermo Scientific™ Dionex™ ICS-6000 DP Pump module or SP Pump module
 - Thermo Scientific™ Dionex™ ICS-6000 EG Eluent Generator module
 - Thermo Scientific™ Dionex™ ICS-6000 DC Detector/Chromatography module with ED Electrochemical Detector
 - Thermo Scientific™ Dionex™ AS-AP Autosampler with sample tray cooling, (P/N 074926)
 - 4-port valve rebuild kit (P/N 074699), which includes a 0.4 µL injection loop
 - Thermo Scientific™ Dionex™ Dual EG Eluent degasser (P/N 22181-60951)
- Thermo Scientific™ Dionex™ ICS-6000 ED Electrochemical Detector Cell (P/N 072044)
- Gold on PTFE disposable working electrode with 1 ml gasket, Pack of 6 (P/N 303397).
- Reference electrode, pH, Ag/AgCl (P/N 061879)
- Thermo Scientific™ Chromeleon™ Chromatography Data System (CDS) software, version 7.2.9
- Thermo Scientific™ SpeedVac™ SPD 140DDA Vacuum Concentrator

Assemble the electrochemical cell following the instructions in the Dionex ICS-6000 operator's manual⁴ and Dionex ED User's Compendium for Electrochemical Detection.⁵

Consumables

- Thermo Scientific™ Nalgene™ Rapid-Flow 0.2 µm filter units, 1000 mL, nylon membrane, 90 mm diameter (Thermo Scientific P/N 164-0020)
- Microcentrifuge tube, 2 mL (Fisher Scientific P/N 05-408-138)
- Nitrogen, ultrahigh purity grade from Airgas
- Thermo Scientific™ Dionex™ EGC 400 KOH Potassium Hydroxide Eluent Generator Cartridge (P/N 302766)
- Thermo Scientific™ Dionex™ EGC 400 MSA Methanesulfonic Acid Eluent Generator Cartridge (P/N 302767)
- Thermo Scientific polypropylene autosampler vials, 1.5 mL (Fisher Scientific P/N NC0380837)
- MilliporeSigma™ Amicon™ Ultra-4 Centrifugal Filter Unit, (Fisher Scientific P/N UFC801096)
- Syringe filter PES 0.45 µm, (Fisher Scientific P/N 09-740-114)
- Filter Paper P8 Grade, (Fisher Scientific P/N 09-795E)

Reagents and standards

- Deionized (DI) water, Type I reagent grade, 18 MΩ·cm resistivity or better
- D-(+)-Galactose, (Sigma-Aldrich P/N G0750-25G)
- D-(-)-Fructose, (Sigma-Aldrich P/N F2543-100G)
- D-(+)-Glucose, (Sigma-Aldrich P/N G8270-100G)
- D-Lactose monohydrate, Sigma-Aldrich P/N 61339-25G)
- Sucrose, (Sigma-Aldrich P/N S7903-250G)
- D-(+)-Maltose monohydrate, (Sigma-Aldrich P/N M5885-100G)
- D-(-)-Arabinose, (Acros Organics, P/N 161450250)
- Carrez I Solution, (Fisher Scientific P/N SC9101500)
- Carrez II Solution, (Fisher Scientific P/N SC9102500)

- Ethanol, 200 Proof (100%), (Fisher Scientific P/N A4094)
- Sodium hydroxide (1 N), (Fisher Scientific P/N SS266-1) – For sample preparation only.

Samples

Three food samples were purchased from a local grocery store.

- Sample #1: Infant formula
- Sample #2: Whey flour
- Sample #3: Chocolate powder

Chromatographic conditions

| Parameter | Value |
|-----------------------------------|--|
| Columns | Dionex CarboPac PA20 Guard, 1 × 30 mm (P/N 303370) Dionex CarboPac PA20 Separation, 1 × 150 mm (P/N 303369) |
| Eluent | Gradient (Table 1) |
| Flow rate | 0.056 mL/min |
| Column temperature | 28 °C |
| Injection volume | 0.4 µL |
| Autosampler temperature | 5 °C |
| Reference electrode | Ag/AgCl |
| Working electrode | Gold disposable electrode with a 1 mil (25.4 µm) gasket |
| Detection | Pulsed amperometric detector (electrochemical detection) |
| Detection compartment temperature | 28 °C |
| Detection waveform | Gold, carbohydrates, 4-potential (Table 2) |
| System backpressure | ~3,700 psi (100 psi = 0.6894 MPa) |
| Run time | 60 min |

System installation and precautions

Install the system according to Figure 1 and the Dual EGC mode installation guide.⁶ An operational vacuum degasser pump (part of the analytical pump) is important to the success of this and other electrochemical detection methods. This pump can be accidentally turned off during a system restart or instrument configuration. If the vacuum degasser pump is not running, poor baseline performance

Table 1. Eluent gradient

| Time (min) | KOH (mM) | KMSA (mM) |
|------------|----------|-----------|
| 0 | 10 | 0 |
| 5 | 10 | 0 |
| 15 | 200 | 0 |
| 20 | 200 | 0 |
| 20.1 | 100 | 100 |
| 25 | 100 | 100 |
| 25.1 | 200 | 0 |
| 40 | 200 | 0 |
| 40.1 | 10 | 0 |
| 60 | 10 | 0 |

Table 2. Carbohydrates, 4-potential waveform

| Time (min) | Potential (V) vs. Ag/AgCl | Integration |
|------------|---------------------------|-------------|
| 0 | 0.1 | Off |
| 0.2 | 0.1 | On |
| 0.4 | 0.1 | Off |
| 0.41 | -2 | Off |
| 0.42 | -2 | Off |
| 0.43 | 0.6 | Off |
| 0.44 | -0.1 | Off |
| 0.5 | -0.1 | Off |

Table 3. Eluent gradient (AOAC Method)

| Time (min) | NaOH (mM) | NaOAc (mM) |
|------------|-----------|------------|
| 0 | 10 | 0 |
| 13 | 10 | 0 |
| 25 | 200 | 0 |
| 25.01 | 600 | 0 |
| 28 | 600 | 0 |
| 28.01 | 10 | 0 |
| 36 | 10 | 0 |

and loss of column compacity can be observed. Always ensure that the vacuum degas pump is on before running a sequence. To do that, press F8 or click the “gear” command button on the main Chromeleon instrument panel and locate the pump and then the degasser status. Choose “Expert” mode from the three modes available—Normal, Advanced, Expert. Check that the degasser is “On”, and “DegasserVaccum” is “OK”. If it is “OFF” and

“NOT OK”, turn on the degasser by selecting “On” from the drop-down menu and wait until “DegasserVacuum” turns to “OK”. If the value reads NOT OK, check for leaks at all the connections necessary for vacuum. Install PEEK backpressure tubing (P/N 22181-20031) as needed to achieve an instrument pressure value above 3,000 psi. To ensure the best system performance, only turn on the EGC power when the system pressure exceeds 3,000 psi. Fill a 2L eluent bottle with degassed DI water. Connect the eluent bottle to the pump, and keep the eluent blanketed under an insert gas (helium or nitrogen) at 5–8 psi to minimize absorption of atmospheric carbon dioxide. Turn on the pump and pump DI water through the Dionex EGC 400 MSA cartridge for 15 min at a flow rate of 1 mL/min. Then condition the Dionex EGC 400 MSA cartridge for 30 min using 100 mM MSA at a flow rate of 0.1 mL/min. Connect the Dionex EGC 400 KOH and pump DI water through the Dionex EGC 400 KOH cartridge for 15 min at a flow rate of 1 mL/min. Condition the Dionex EGC 400 KOH cartridge for 30 min using 100 mM KOH at a flow rate of 0.1 mL/min. After conditioning the EGCs, install the Dionex CarboPac PA20-1mm column set, and set KMSA and KOH to the desired concentrations for the application, and keep the flow on at 0.056 mL/min for 60 min.

Preparation of solutions and reagents

Sodium hydroxide solution, 38.5 mM: Add approximately 400 mL of water to a 500 mL volumetric flask. Weigh 29 ± 0.5 g of 1 N sodium hydroxide into the flask. Bring to volume with water and mix thoroughly.

Standards

Internal standard stock solution, (100 mg/mL arabinose): Weigh 2.50 ± 0.01 g of arabinose. Transfer to a 25 mL volumetric flask. Add approximately 15 mL water. Stir until completely dissolved and sonicate as needed. Bring to volume with water.

Intermediate internal standard solution (1,000 mg/L arabinose): Pipet 1 mL of internal standard stock solution into a 100 mL volumetric flask. Dilute to volume with water. Mix well.

Reference standard stock solution (mixed sugar standard), 1,000 mg/L: Weigh 100 mg of sugar standard (galactose, fructose, glucose, and sucrose), 105.3 mg of (lactose monohydrate and maltose monohydrate). Transfer to a 100 mL volumetric flask. Add approximately 80 mL water. Mix thoroughly until completely dissolved. Bring to volume with water.

Working standard solutions

Prepare seven calibration standard working solutions by combining appropriate volumes of the Intermediate Internal Standard Solution and the Reference Standard Stock Solution in separate 100 mL volumetric flasks as indicated in Table 4. Bring to volume with water and mix each solution well.

Extraction solution: Combine equal volumes of ethanol and water in an appropriate container. Mix thoroughly.

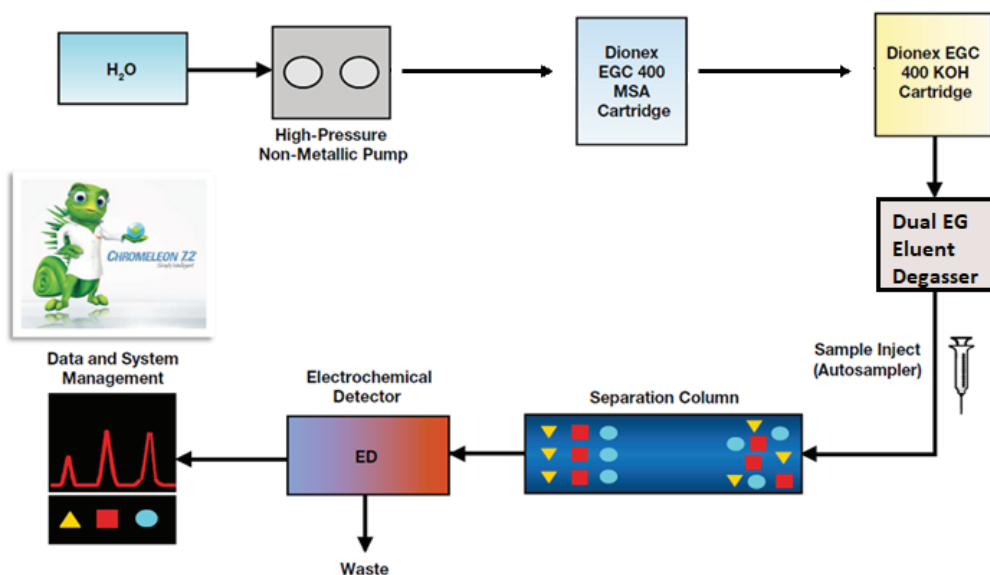

Figure 1. Dionex ICS-6000 HPIC system in Dual EGC mode

Table 4. Sugar calibration standards

| Calibration working standard | Intermediate internal standard solution volume (µL) | Reference stock concentration (µL) | Final volume (mL) | Target concentration (mg/L) |
|------------------------------|---|------------------------------------|-------------------|-----------------------------|
| 1 | 500 | 25 | 100 | 0.25 |
| 2 | 500 | 50 | 100 | 0.5 |
| 3 | 500 | 200 | 100 | 2 |
| 4 | 500 | 500 | 100 | 5 |
| 5 | 500 | 1000 | 100 | 10 |
| 6 | 500 | 1500 | 100 | 15 |
| 7 | 500 | 2500 | 100 | 25 |

Sample preparation

Follow the sample preparation procedure outlined in the AOAC 2018.16 First Action Method. Three extractions methods were listed in AOAC 2019.16 First Action depending on the protein and sugar level in the sample:

- Method (a) Low Protein Matrices, <35% total protein on dry matter basis
- Method (b) High Protein Matrices using Carrez extraction, >35% total protein on a dry matter basis
- Method (c) High Sugar Matrices, >30% individual sugar compound or >50% total sugar content on as-is basis

Take method (b) as an example. Weigh 2.5 g of sample, add 250 µL of internal standard stock solution. Extract with 500 mL of 50% ethanol for 1 h. Filter extract and remove protein from the extract using Carrez I and II solutions. Remove large molecules using 10K molecular weight filters. Dry the extract and redissolve in DI water. Dilute with DI water as necessary and filter the solution using a disposable 0.45 µm PES syringe filter.

Method (a) skips the step to remove protein from the extract using Carrez I and II solutions from method (b).

Method (c) extracts sample with 250 mL of DI water for 1 h and then adds 250 mL of ethanol.

Three samples were used for this study. Sample #1 (infant formula) follows method (a), sample #2 follows method (b), and sample #3 follows method (c).

Results and discussion

Separation

The Dionex CarboPac PA20 column has been specially developed to provide high-resolution separation of monosaccharides and disaccharides.^{7,8} The determination of nutritionally relevant carbohydrates, including galactose, glucose, fructose, sucrose, lactose, and maltose, in foods was described in the AOAC 2018.16 First Action Method. The method uses HPAE-PAD with manually prepared sodium hydroxide eluents (Table 3). The starting 10 mM NaOH (0–13 min) is to separate monosaccharides. The gradient from 10 mM to 200 mM (13–25 min) is to separate disaccharides. 600 mM NaOH (25–28 min) is used for washing oligosaccharides from the column, and there is a return to starting condition (28–36 min) to re-equilibrate the column prior to the next injection.

Dual EGC mode replaces the manual preparation of the sodium hydroxide/sodium acetate eluents. This mode uses a methanesulfonic acid (MSA) eluent generation cartridge (EGC) and a potassium hydroxide (KOH) EGC in series to generate an extremely reproducible and accurate KOH/KMSA eluent gradient needed for separating complex carbohydrates. A Dionex CarboPac PA20 column in a 1 mm diameter format was recently launched for use with the Dual EGC mode. Dual EGC mode limits the total concentration of KOH + KMSA < 200 mM. Therefore, we need to develop Dual EGC mode eluent conditions to achieve a similar separation. We developed the gradient given in Table 1 to separate sugars and wash the column, followed by column re-equilibration. KMSA is a stronger eluent than sodium hydroxide. Therefore, for the dual EGC method, 100 mM KOH +100 mM KMSA (20–25 min) was used for washing oligosaccharides from the column. Longer re-equilibration time is required for the Dual EGC mode due to the eluent composition. The AOAC 2018.16 Method uses a column temperature of 30 °C, which does not separate mannose and sucrose. In this work, column temperature was modified from 30 °C to 28 °C to separate

the pair. Figure 2 shows the separation of six sugars and arabinose using a Dionex CarboPac PA20-1 mm column set. The peaks are well separated and easily quantified. The non-target mono- and disaccharide, sugar alcohol, and amino sugar interferences were evaluated by mixing them with target sugars. Those potential interferences are not expected to be present in high amounts in food samples. Figure 3 shows that galactose, glucose, sucrose, fructose, lactose, and maltose are all sufficiently resolved from potential interferences to allow an accurate determination of each of the analytes.

To confirm the effectiveness of the 5 min column rinsing step using 100 mM KOH + 100 mM KMSA, retention time stability was monitored. The retention times of sugars were stable for 15 days of continuous injections of samples and standards. If over longer analysis times retention times shorten, column cleaning with stronger manually prepared eluents may be necessary.

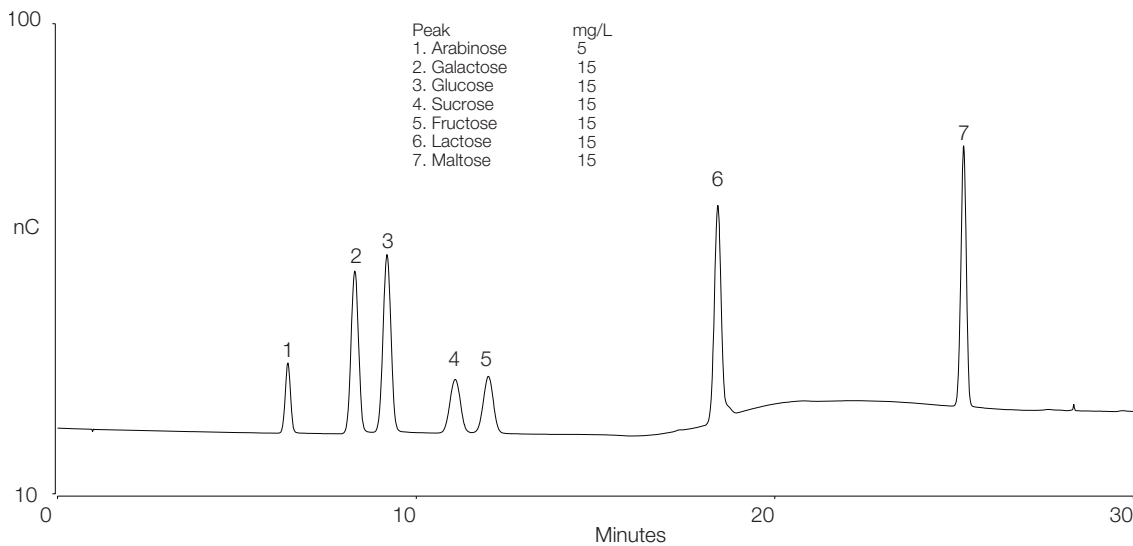

Figure 2. Separation sugar standards using a Dionex CarboPac PA20-1 mm column set

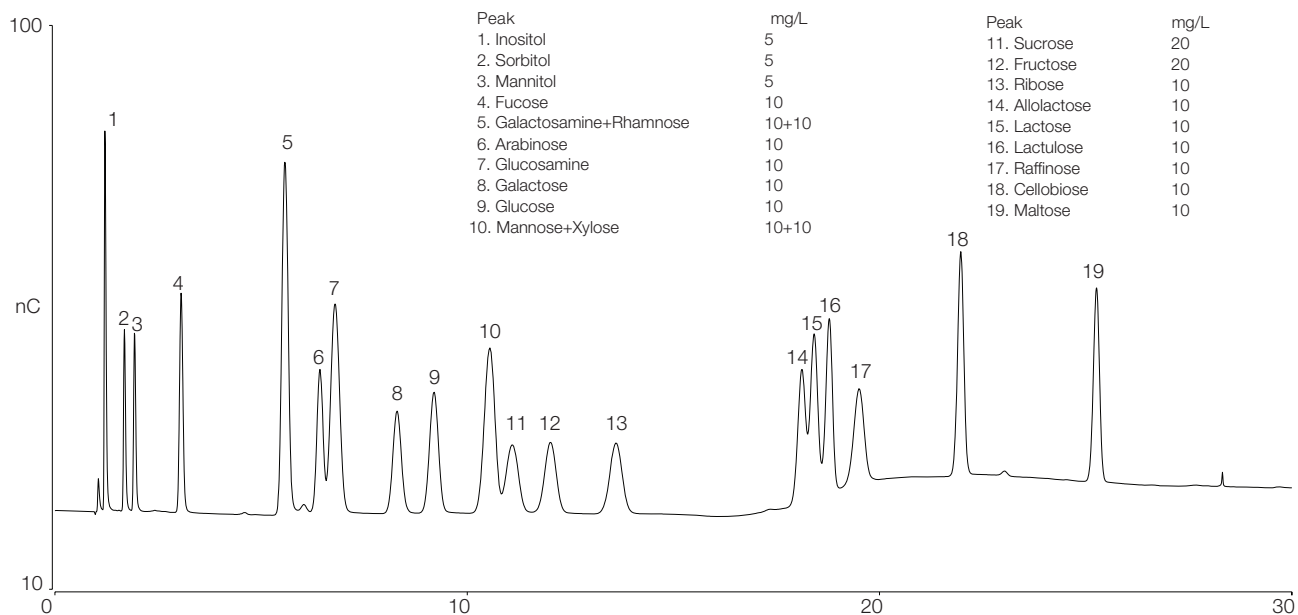

Figure 3. Separation of target sugars from interference sugars using a Dionex CarboPac PA20-1 mm column set

Calibration, limit of detection (LOD), and limit of quantification (LOQ)

Calibration curves with seven concentration levels (Levels 1–7) were constructed for sugars using arabinose as an internal standard. Table 5 shows the calibration results. Figure 4 shows the six calibration curves. The calibration curves of lactose and maltose showed linearity in the selected calibration ranges with coefficients of determination (r^2) greater than 0.999. The calibration curves of galactose, glucose, sucrose, and fructose exhibited quadratic fitting in the selected calibration ranges with coefficients of determination (r^2) greater than 0.999.

The determination of LOD was based on the signal-to-noise (S/N) ratio. The S/N ratio is determined by comparing the measured signal from a standard with a low concentration of analyte with those of a blank and establishing the minimum concentration at which the analyte can be reliably detected. A S/N = 3 is used to estimate LOD, and a S/N = 10 is used to estimate the quantification limit (LOQ).⁹ In this study, the baseline noise was first determined by measuring the peak-to-peak noise in a representative 1 min segment of the baseline where no peaks elute but close to the peak of interest. The signal was determined from the average height of three injections of galactose and glucose at 5 µg/L and sucrose, fructose, lactose, and maltose at 10 µg/L. Table 6 summarizes the LOD and LOQ results.

Table 5. Calibration results

| Standard | Range (mg/L) | Calibration type | Coefficient of determination (r^2) |
|-----------|--------------|------------------|--|
| Galactose | 0.25–25 | Quad, WithOffset | 1 |
| Glucose | 0.25–25 | Quad, WithOffset | 1 |
| Sucrose | 0.25–25 | Quad, WithOffset | 0.9996 |
| Fructose | 0.25–25 | Quad, WithOffset | 0.9999 |
| Lactose | 0.25–25 | Lin, WithOffset | 0.9998 |
| Maltose | 0.25–25 | Lin, WithOffset | 0.9999 |

Sample analysis

Table 6. LOD and LOQ

| Analyte | LOD (µg/L) | LOQ (µg/L) | LOD in sample powder (µg/g) | LOQ in sample powder (µg/g) |
|-----------|------------|------------|-----------------------------|-----------------------------|
| Galactose | 4.11 | 13.7 | 8.22 | 27.4 |
| Glucose | 3.52 | 11.7 | 7.05 | 23.5 |
| Sucrose | 7.62 | 25.4 | 15.2 | 50.8 |
| Fructose | 8.84 | 29.5 | 17.7 | 59.0 |
| Lactose | 9.04 | 30.1 | 18.1 | 60.2 |
| Maltose | 9.82 | 32.7 | 19.6 | 65.5 |

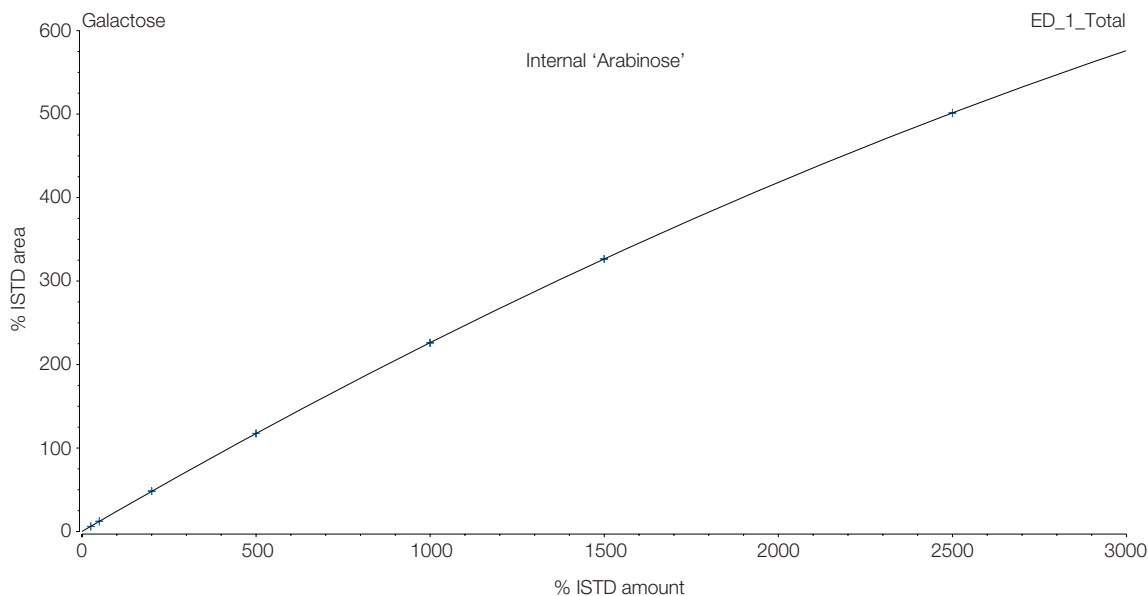

Figure 4. Sugar calibration curves

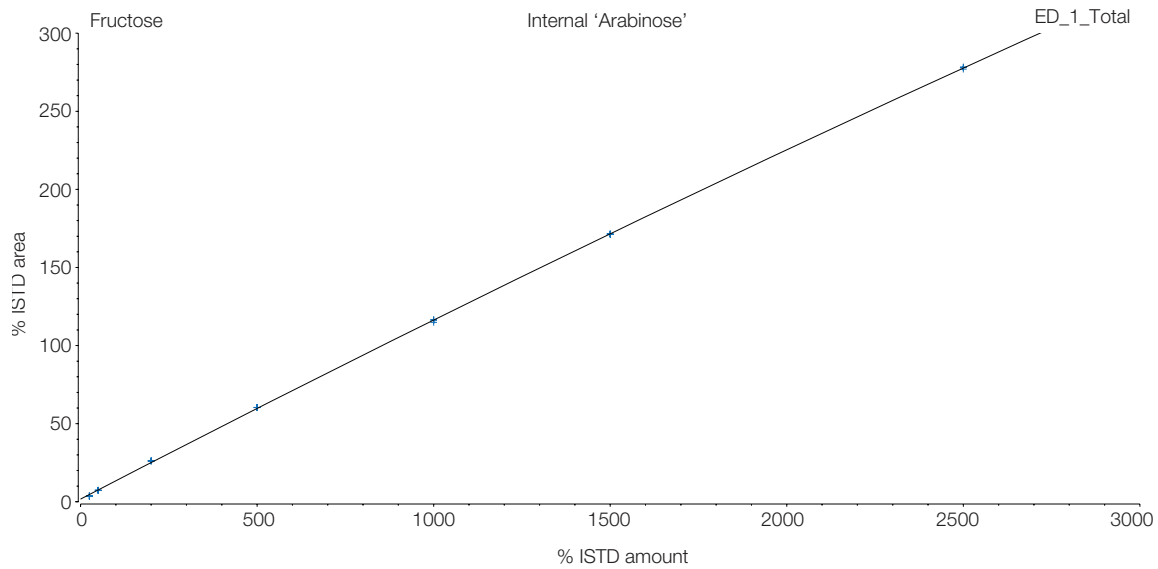
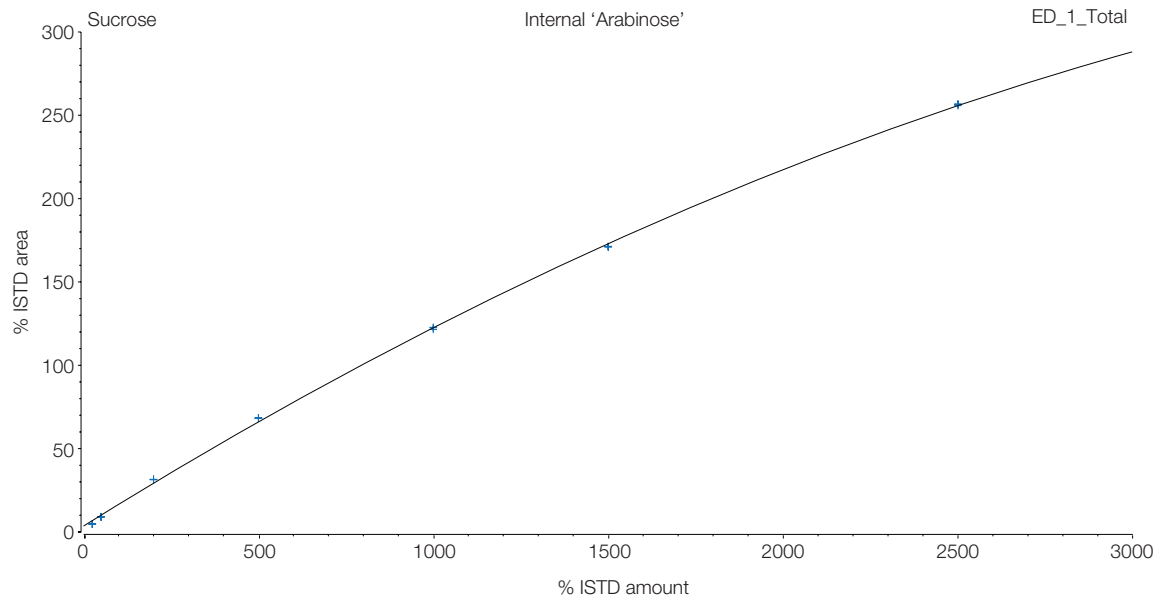
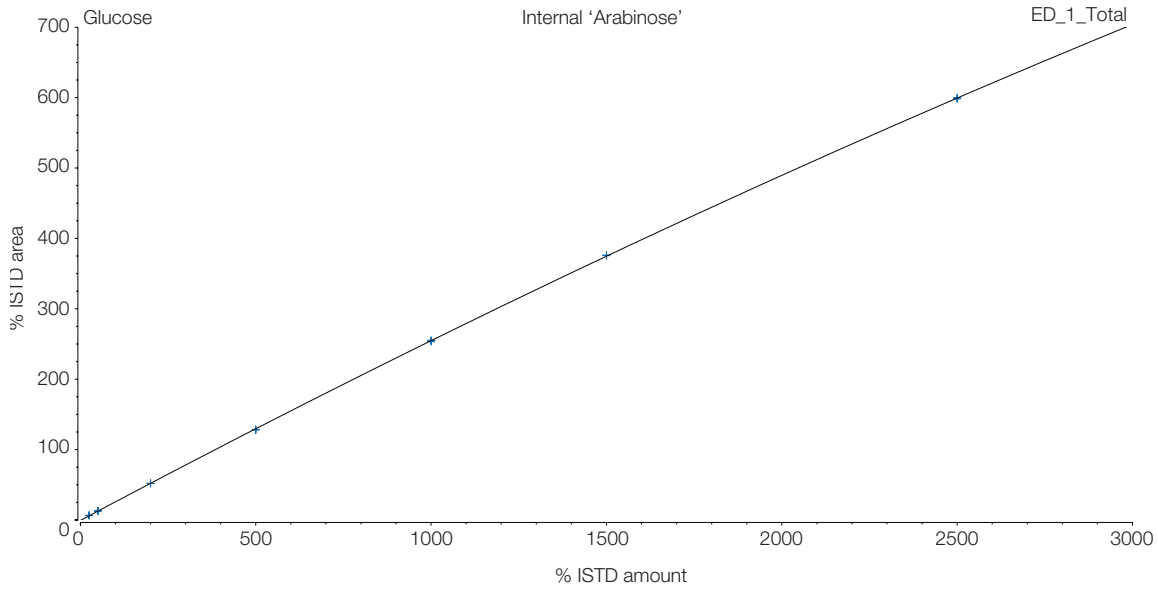

Figure 4 (continued). Sugar calibration curves

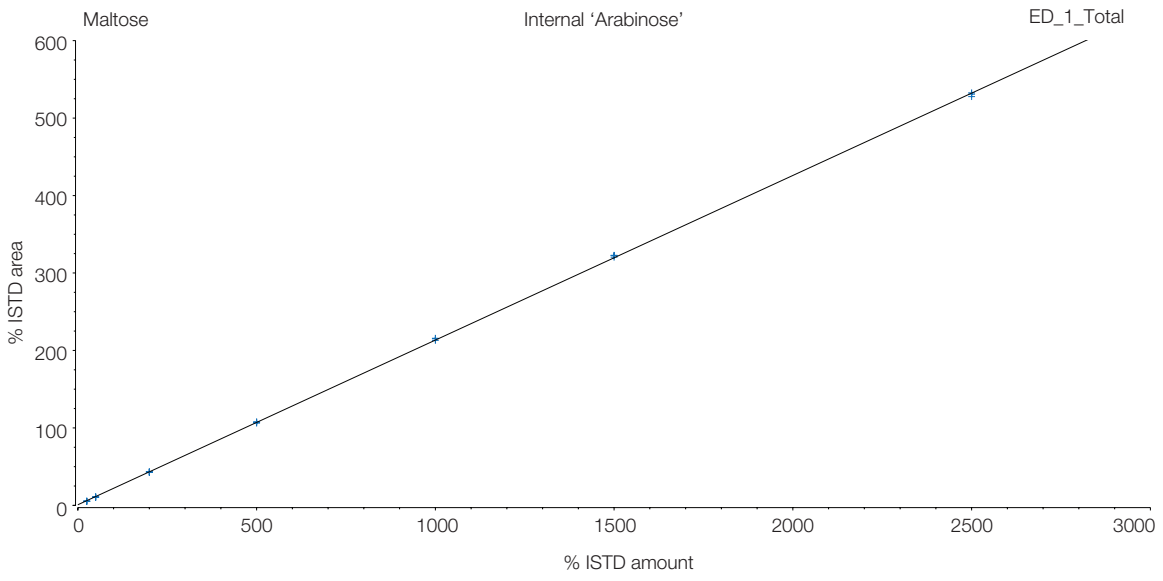
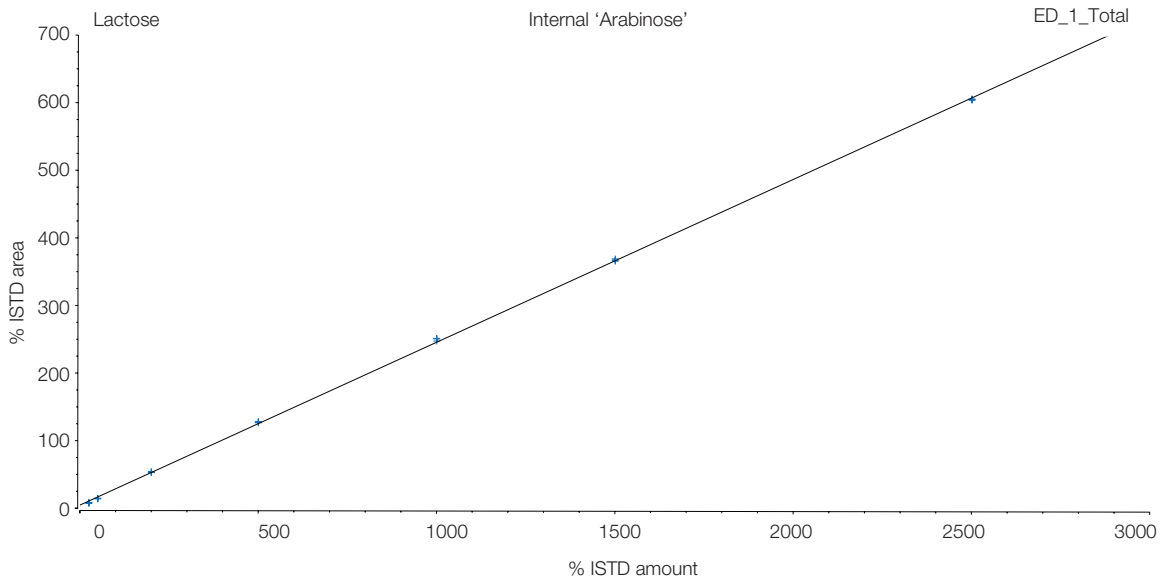

Figure 4 (continued). Sugar calibration curves

Three food samples were analyzed in this study. Sample #1 (infant formula), sample #2 (whey flour), and sample #3 (chocolate powder) used AOAC 2018.16 sample preparation methods (a), (b), and (c), respectively. Duplicate extraction was performed for each sample. Figure 5 shows the separation of sugars in three food samples. Target sugars are well separated from interferences. Lactose in sample #1 and sucrose in sample #3 were out of their calibration range. Therefore, lactose in sample #1 was quantified by diluting the extract 20-fold, and sucrose in sample #3 was quantified by diluting the extract 30-fold (Figure 6). Table 7 shows the calculated results.

Method accuracy was evaluated through spike recovery studies. Sugar was spiked into each diluted sugar extract at 0.5 mg/L. The recovery for sugars in the three samples ranged from 91 to 110%. The inter-day precision was determined by triplicate injection of the level-4 calibration standard on three separate days. The calculated peak area precision varied from 0.42 to 1.6%, with retention time precision <0.2% for all target carbohydrates. The high performance is consistent with results obtained with a system using eluent generation.

Method accuracy and precision

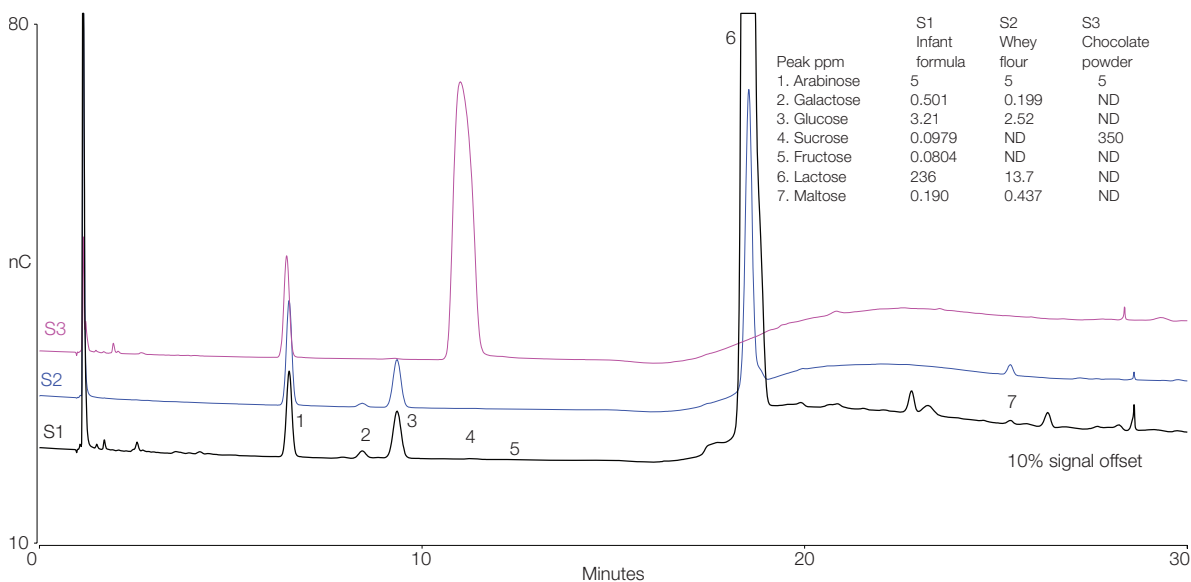

Figure 5. Sugar determination of three food samples

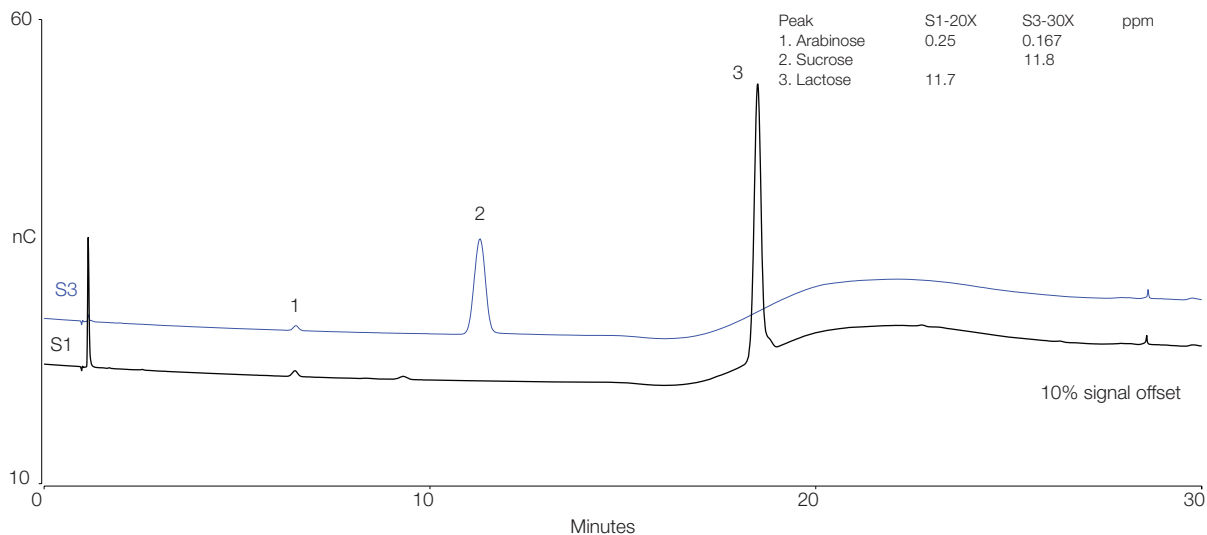

Figure 6. Sugar determination of two food samples (diluted extract)

Table 7. Sugars in sample (g/100 g)

| Analyte | Galactose | Glucose | Sucrose | Fructose | Lactose | Maltose |
|--------------------------------|-----------|---------|---------|----------|---------|---------|
| Sample 1 (Infant formula) | 0.101 | 0.643 | 0.0202 | 0.0167 | 46.3 | 0.0378 |
| Sample 2 (Whey flour) | 0.0397 | 0.507 | ND | ND | 2.72 | 0.0864 |
| Sample 3 (Chocolate powder) | ND | ND | 69.0 | ND | ND | ND |

Conclusion

This application note demonstrated that the AOAC 2018.16 First Action Method for sugar determination in food samples could be successfully modified for use with a Dionex CarboPac PA20-1 mm column and HPAE-PAD in Dual Eluent Generation Cartridge Mode. The separation, linearity, sensitivity, accuracy, and reproducibility were excellent. Compared with a traditional HPAE-PAD separation of sugars using manually prepared sodium hydroxide eluents, the Dual EGC method delivered a similar resolution of sugars, simplified operation (no eluent preparation), and improved retention time precision.

References

1. Official Methods of Analysis (2012) 19th Ed., AOAC INTERNATIONAL, Rockville, MD, Method 996.11.
2. Li, K.; Lui, S.; Tan, Y.; Chao, N.; Tian, X.; Qi, L.; Powell, W.A.; Jiang, X.; Gai, Y. Optimized GC-MS Method to Simultaneously Quantify Acetylated Aldose, Ketose, and Alditol for Plant Tissues Based on Derivatization in a Methyl Sulfoxide/1-Methylimidazole System, *J. Agric. Food Chem.* 2013, 61, 4011–4018.
3. Vennard, T.R.; Ruosch, A.J.; Wejrowski, S.M.; Ellingson, D.J. Sugar Profile Method by High-Performance Anion-Exchange Chromatography with Pulsed Amperometric Detection in Food, Dietary Supplements, Pet Food, and Animal Feeds: First Action 2018.16, *Journal of AOAC INTERNATIONAL* 2020, 103(1), 89–102.
4. Thermo Scientific Dionex ICS-6000 Ion Chromatography System Operator’s Manual, P/N 22181-97002, February 2018. <https://assets.thermofisher.com/TFS-Assets/CMD/manuals/man-22181-97002-ics-6000-man2218197002-en.pdf>
5. Thermo Scientific Electrochemical Detection User’s Compendium, P/N 065340-02, April 2013. <http://tools.thermofisher.com/content/sfs/manuals/Man-065340-Electrochemical-Detection-Man065340-EN.pdf>
6. Thermo Scientific Dionex ICS-6000 Ion Chromatography System Dual EGC Mode Installation, P/N 065760 May 2020. <https://assets.thermofisher.com/TFS-Assets/CMD/manuals/ii-065760-ics-6000-dual-egc-ii065760-en.pdf>
7. Thermo Scientific Dionex CarboPac PA20 Columns Product Manual, P/N 031884, November 2018. <https://tools.thermofisher.com/content/sfs/manuals/4378-Man-031884-05-CarboPac-PA20-Jul11.pdf>
8. Thermo Scientific Dionex Bio-IC Column Selection Guide. <https://assets.thermofisher.com/TFS-Assets/CMD/brochures/st-71322-ic-bio-column-selection-guide-st71322-en.pdf>
9. ICH Guideline Q2B, Validation of Analytical Procedures, Methodology (CPMP/ICH/281/95), Geneva, Switzerland, November 1996.

Find out more at [thermofisher.com/complexcarbs](https://www.thermofisher.com/complexcarbs)