

Alkanolamine determinations in neutralizing amines samples with improved separation technology

Authors

Terri Christison, John Guajardo, and Jeffrey Rohrer

Thermo Fisher Scientific,
Sunnyvale, CA

Keywords

IonPac CS20 column, RFIC, Reagent-Free IC, Integrion, IC, cations, alkanolamines, amine gas treatment, scrubbing amines

Goal

Update alkanolamine determinations in neutralizing amines samples with improved separation technology

Introduction

Natural gas (methane) is an important energy resource, accounting for 29% of the total energy consumed in 2017. Natural gas is used primarily as fuel to generate electricity and as feed stock for plastic materials.¹ As a result of hydraulic fracturing of previously inaccessible shale deposits, the United States has moved from a moderate producer to the highest producer of natural gas replacing Russia in 2009, and similarly in petroleum hydrocarbons, replacing Saudi Arabia in 2013.¹

Natural gas, withdrawn from traditional petroleum wells, generally needs limited purification prior to selling it as a natural gas product. In contrast, wet natural gas withdrawn from wells using hydraulic fracturing requires additional processing to remove the water, C₂ to C₅ hydrocarbons, and sometimes hydrogen sulfide (H₂S) and carbon dioxide (CO₂) before it can be sold.² Sour crude natural gas, defined as containing carbon dioxide (CO₂) and hydrogen sulfide gases (H₂S > 5.7 mg/m³), is very acidic, toxic, and highly corrosive, requiring amine gas treatment with amine-rich scrubber solutions to neutralize the CO₂ and remove the H₂S gas impurities.^{3,4} Amine gas treatment (also named amine scrubbing, gas sweetening)⁵ typically uses percent concentrations of alkanolamines, such as ethanolamine (EA), diethanolamine (DEA), triethanolamine (TEA), and methyldiethanolamine

(MDEA), to neutralize the sour gas impurities. When the neutralizing capacity is deemed inefficient, the amine solutions are regenerated and stripped of elemental sulfur. Dissolved salts (heat stable amine salts) remain, building up over time and resulting in higher maintenance costs and higher incidents of corrosion.⁵ Determinations of both the amine concentrations and the heat stable amine salts are needed to ensure a pure product and an efficient amine gas treatment process. These determinations can be challenging in the concentrated alkanolamine solutions.

For the determination of ionic components, ion chromatography (IC) with suppressed conductivity detection is the analytical method of choice as previously demonstrated for anionic heat stable amine salts, cations and alkanolamines, and with coupling to mass spectrometry.⁶⁻¹¹ The determinations of the alkanolamines and degradation products are challenging because of the variability in the composition of the neutralizing amine, degradation products, and salts; and therefore, different stationary phase selectivity is often needed.

This application note demonstrates the separations of µg/L to 25 mg/L concentrations of inorganic cations (sodium, magnesium, calcium) and ammonium, and µg/L to 1250 mg/L concentrations of alkanolamines (EA, DEA, TEA, MDEA, methylaminoethanolamine (MAEA), and dimethylaminoethanolamine (DMAEA)) in 1000-fold diluted neutralizing amine (alkanolamine) solution sample using a 0.4 µL internal sample loop and an electrolytically generated eluent gradient on the Thermo Scientific™ Dionex™ IonPac™

CS20 (2 × 250 mm) cation-exchange column. The Dionex IonPac CS20 column is optimized for hydrophilic amines using three types of cation-exchange functional groups, resulting in unique selectivity.¹² As the ions elute from the column, they are detected by suppressed conductivity within 35 min. This method provides an alternative approach to the determination of alkanolamine solutions with the advantages of a different selectivity that provides an elution window for the alkanolamines, and a small volume injection to minimize column overload by injections of 1000-fold diluted alkanolamines.

Experimental Equipment

- Thermo Scientific™ Dionex™ Integrion™ HPIC™ system, RFIC model*
 - Detector Compartment Temperature Control
 - Eluent generation
- Thermo Scientific™ Dionex™ Integrion IC Conductivity Detector, P/N 079829
- Thermo Scientific™ Dionex™ Integrion 4-port Injection Valve Pod (0.4 µL internal sample loop), P/N 22153-62026
- Thermo Scientific™ Dionex™ AS-AP autosampler with temperature control

*Or other Thermo Scientific™ Dionex™ HPIC system

Table 1 lists the consumable products needed for the Dionex Integrion RFIC system.

Table 1. Consumables list for the Dionex Integrion HPIC System*

Product Name	Description	P/N
Thermo Scientific™ Dionex™ IC PEEK Viper™ fitting tubing assembly kit	Dionex IC Viper fitting assembly kit for the Dionex Integrion RFIC system with CD: Includes one each of P/Ns: 088805–088811	088798
Thermo Scientific™ Dionex™ EGC 500 MSA Eluent Generator cartridge	Cation eluent generator cartridge for the Integrion system	075779
Thermo Scientific™ Dionex™ CR-CTC 600 Electrolytic trap column	Continuously regenerated trap column used with Dionex EGC 500 MSA cartridge on Dionex Integrion and ICS-6000 HPIC systems	088663
Thermo Scientific™ Dionex™ HP EG Degasser Module	Degasser installed after Dionex CR-TC trap column and before the injection valve, used with eluent generation, included with installation	075522
Thermo Scientific™ Dionex™ CDRS 600 suppressor	Cation suppressor for 2 mm columns	088670
Dionex IonPac CG20 Guard Column	Cation guard column, 2 × 50 mm	302607
Dionex IonPac CS20 Analytical Column	Cation analytical column, 2 × 250 mm	302606
Syringe filters	Syringe filters suitable for IC, 0.45 µm, PES	Fisher Scientific 725-2545

Software

Thermo Scientific™ Chromeleon™ Chromatography Data System (CDS) Software 7.2 was used for data acquisition and processing.

Conditions

Columns:	Dionex IonPac CG20 (2 × 50 mm) and Dionex IonPac CS20 (2 × 250 mm)
MSA Gradient:	2.5–4.0 mM MSA (0–15 min), 4.0–6.8 mM (15–22 min), 6.8–60 mM (22–24 min), 60 mM (24–30 min), 2.5 mM (30.1–35 min)
Eluent Source:	Dionex EGC 500 MSA eluent cartridge, Dionex CR-CTC 600 trap column and high pressure degas module
Flow Rate:	0.3 mL/min
Injection Volume:	0.4 µL internal loop using a 4-port injection valve pod, PushCap mode, 100× overfill of loop, 2× buffer loop
Column Temperature:	35 °C
Detection/Suppressor Compartment:	20 °C
Detection:	Suppressed conductivity, Dionex CDRS 600 suppressor, 2 mm, 68 mA, constant current and recycle modes
Background:	<1 µS/cm
Noise:	<1 nS/cm
System Backpressure:	~3100 psi
Run Time:	35 min

Reagents

ASTM Type 1 deionized water (DI water) with 18 MΩ·cm resistivity¹³

Fisher Scientific™, ACS Certified grade:

- Sodium chloride, crystalline, S271-500
- Ammonium chloride, crystalline, A661-500 or
- Calcium chloride dihydrate, crystalline, C79-500
- Magnesium chloride, hexahydrate, crystalline, M33-500

Sigma-Aldrich, ACS Reagent grade:

- Diethanolamine (DEA), crystalline, P/N D8885-500mL
- 2-Dimethylaminoethanol (DMAEA), P/N 471453-100mL
- Ethanolamine (EA), P/N 411000-100mL
- 2-Methylaminoethanolamine (MAEA), P/N 471445-25mL
- Methyldiethanolamine (MDEA), P/N 471825-250mL
- Triethanolamine (TEA), P/N 90279

Standard and sample preparation

Standards

Prepare the stock standards by adding the reagent (Table 2) to a 100 mL HDPP bottle, adding 100 g of DI water, capping the bottle, and shaking until the reagent is fully dissolved. Label and store at 20 °C.

Prepare a 100 mg/L combined intermediate standard by adding 10 g of each 1000 mg/L individual stock standard to a 100 mL HDPP bottle. Add DI water to a final weight of 100.00 g. Cap the bottle and invert to mix. Store the standard at 20 °C until it is needed.

For the high concentration calibration curve, prepare the combined EA, DEA, TEA, and MDEA working standards by diluting the 10,000 mg/L individual stock standards with DI water to 50, 100, 250, 500, 750, 1000, and 1250 mg/L combined standards. For the low concentration calibration curve, prepare the 0.5, 1.0, 2.5, 5, 10, and 25 mg/L of the EA, DEA, TEA, MDEA, sodium, ammonium, magnesium, and calcium combined working standards from the 100 mg/L combined amine standard and DI water. A reproducibility standard of 20 mg/L EA, DEA, MDEA, MAEA, and DMAEA, 40 mg/L TEA, 5 mg/L sodium, ammonium, magnesium, and calcium was prepared similarly from the stock or intermediate standards.

Table 2. Preparation of 1000 mg/L cation and 10,000 mg/L alkanolamine stock standards

Analyte: Reagent	FW (g/mol) / (Density, g/mL) ¹⁴	Reagent (mg)	DI water (g)	Final Conc. (mg/L)
Ammonium: Ammonium chloride	53.489	297	0.015	0.052
Calcium: Calcium chloride, dihydrate	147.01	368	100.00	1000
DEA	105.137 (1.09)*	1000	99.08	10,000
2-Dimethylaminoethanol (DMAEA)	89.138 (0.89)*	1000	98.88	10,000
Ethanolamine (EA)	45.085 (0.81)*	1000	98.80	10,000
Magnesium: Magnesium chloride, hexahydrate	203.29	847	100.00	1000
Methylaminoethanolamine (MAEA)	75.111 (0.94)*	1000	99.94	10,000
Methyldiethanolamine (MDEA)	119.164 (1.04)*	1000	99.04	10,000
Sodium:Sodium chloride	58.44	254	100.00	1000
Triethanolamine (TEA)	149.19 (1.1)*	1000	99.09	10,000

Samples

Dilute the alkanolamine neutralizing amine solution samples 1000-fold prior to analysis. If particulates are observed, filter samples (0.45 µm, nylon).

Instrument setup and installation

4-Port injection valve pod

To install the 4-port injection valve pod with 0.4 µL internal loop and remove the 6-port injection valve pod in the Dionex Integrion HPIC system, first power down the system. Loosen and remove the black knob around the 6-port injection valve. Pull out the injection valve pod. Note the positions of the slots on the inside of the injection valve pod. Align the slots of the 4-port injection valve pod in the same way. Push the 4-port injection pod into position. Rotate the injection valve pod slightly clockwise and counterclockwise to ensure that the pod is correctly positioned. Install the black knob. Power up the system. Detailed installation instructions for replacing a high-pressure valve pod can be found in the Dionex Integrion HPIC System Operators Manual.¹⁴

Physical and electronic configuration

To configure the Dionex Integrion HPIC system, follow the instructions in Thermo Scientific Technical Note

TN175: Configuring the Dionex Integrion HPIC System for High-Pressure Reagent-Free Ion Chromatography.¹⁵ Install power and USB cables, and power-up the IC, autosampler, and computer. To electronically configure the IC system, start the Chromeleon CDS Instrument Services program, then start the Instrument Controller program by selecting the *Configure instruments* link. Add the Integrion HPIC system, the Integrion HPIC Pump wellness, and the AS-AP Autosampler modules as described in TN175. For the AS-AP autosampler module, select the vial types, the syringe type (250 µL), and sample loop (0.4 µL). Close and save the module configuration by selecting "OK". Check and correct the configuration for any errors. Save and close the configuration program.

Plumbing the Dionex Integrion HPIC system, RFIC model

Plumb the Dionex Integrion IC as a standard Reagent-Free™ IC (RFIC™) system using the IC PEEK Viper fittings as shown in Figure 1 and described in TN175. The schematics are also illustrated on the inside doors of the Dionex Integrion IC system. Direct the waste lines, including the wire wrapped waste line to the waste containers.

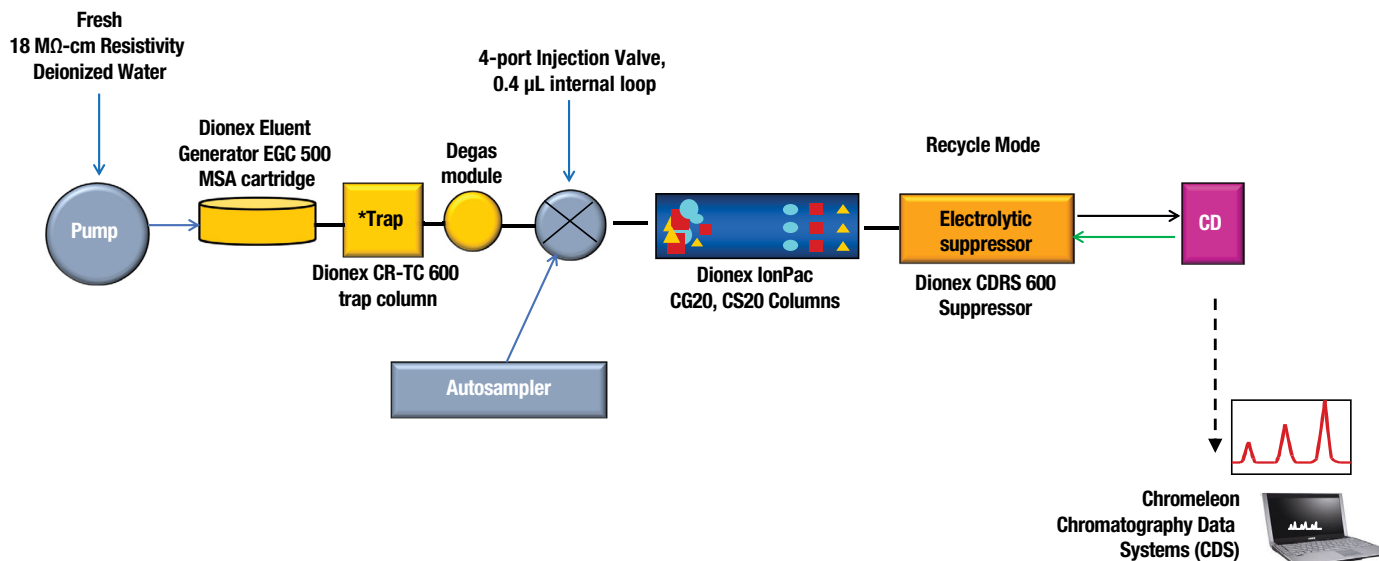

Figure 1. Flow diagram for setting up this application

Conditioning electrolytic devices and columns

Important: Do not remove consumable tracking tags on the columns and consumable devices. These tags are required for consumables monitoring functionality.

Hydrate and condition the Dionex EGC 500 MSA eluent generator cartridge and Dionex CR-CTC 600 Continuously Regenerated Trap column according to TN175, product manuals, or the instructions in the drop-down menu (Chromeleon Console, under Consumables drop down menu).¹⁴⁻¹⁷ Condition the columns as described in the Dionex IonPac CS20 product manual or Consumables Conditioning instructions (Chromeleon Console, under Consumables drop-down menu), 30 mM MSA, 30 °C at 0.30 mL/min for 30 min while directing the effluent to waste.¹⁸ Install the conditioned columns according to Figure 1.

Hydrating the suppressor

To hydrate the Dionex CDRS 600 suppressor, follow the instructions in the Suppressor Installation Checklist that is included with the suppressor.¹⁹ Install the suppressor according to Figure 1. To ensure that the suppressor is within backpressure specifications, follow the instructions in the Suppressor Installation Checklist. The backpressure by the suppressor (1) should be <50 psi, whereas the backpressure applied after the suppressor

(2) should be <100 psi. CDRS suppressor operation is thoroughly discussed in the Dionex DRS 600 suppressor manual.²⁰

System startup, conditioning, and consumables device tracking

Equilibrate the IC using the Quality Assurance Report (QAR) conditions for the Dionex IonPac CS20 column until the total conductivity is <2 μS/cm. Using the Chromeleon Wizard program, create a new instrument method using the QAR conditions, and a new processing method. Approve the consumables in the Consumables Tracking panel located on the Chromeleon console (TN175). Start the Chromeleon sequence. Compare the results against the QAR report. Create another sequence using the application conditions and standard and sample positions to run the application.

Results and discussion

In this application note, six alkanolamines and four cations in the alkanolamine-based amine neutralizing samples were separated on a Dionex IonPac CS20 column at 0.3 mL/min and 35 °C using a 0.4 μL internal injection port. The cations were separated using an electrolytically generated MSA gradient. The results of the method optimization and qualification, and sample analysis are discussed here.

Method optimization

To optimize this method, the separation of the ions of interest was evaluated on the Dionex IonPac CS20 cation-exchange column at a fixed temperature, then optimized for separation temperature and finally for sample loading by minimizing the sample injection volume.

Dionex IonPac CS20 cation-exchange column

The Dionex IonPac CS20 column was selected for this application because of the column's improved selectivity for monovalent ions and higher stationary phase stability at typical and elevated separation temperatures. These characteristics were achieved using three functional groups (carboxylated, phosphorylated, and sulfonated) instead of only carboxylated functional groups as in many existing cation-exchange columns designed for this application.¹² The improved selectivity for monovalent ions results in an elution window for the alkanolamines between the monovalent Group I cations (alkali metals) and divalent Group II cations (alkaline earth metals). Figure 2 illustrates the structure of the Dionex IonPac CS20 column resin particles.

Gradient conditions

As a result of the stationary phase selectivity, the monovalent ions were retained longer on the Dionex IonPac CS20 stationary phase and required lower eluent concentrations to elute the ions than other cation exchange columns using only carboxylated ion exchange groups. Consequently, the first peaks can elute as late as 12 min with 2.5 mM MSA. The separation of a mixed cation, alkanolamine standard (5 mg/L sodium, ammonium, magnesium, and calcium, 20 mg/L EA, DEA, TEA, MDEA, MAEA, and DMAEA) was evaluated at 5

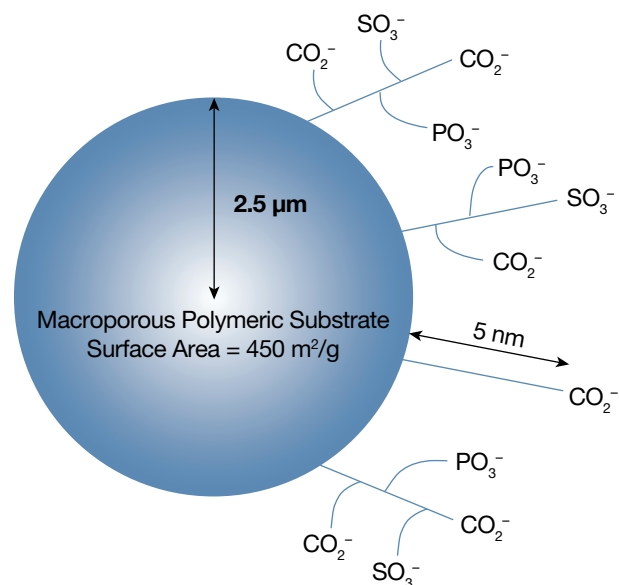

Figure 2 was obtained from Reference 12.

Figure 2. Structure of Dionex IonPac CS20 column resin particle

and 10 mM MSA starting conditions, but the resolution of alkanolamines was poor. The final gradient used a low starting concentration (2.5 mM MSA), a shallow gradient slope in the alkanolamine elution window, and a steep gradient to quickly elute magnesium and calcium.

Separation conditions at 70 °C were reported in the column manual and product specifications brochure,^{12,18} indicating great stability at elevated temperature conditions. To optimize the separation temperature, the separation of select ions, particularly the alkanolamines, was evaluated at 30, 35, 40, 45, and 50 °C, and 35 °C was found to have the best resolution of the alkanolamines.

After the initial injections of 1000-fold diluted samples, it was apparent that the high concentrations of amines were overloading the column. To reduce sample preparation time and for convenience, the application was modified with a 4-port injection valve containing a 0.4 μ L internal injection loop. Figure 3 shows the mixed cation-alkanolamine standard separated with the final application conditions. All ions of interest were baseline resolved except for TEA-MDEA, which are nearly baseline-resolved.

Method qualification

To qualify the method, the calibration ranges, method detection limits (MDLs), and retention time and peak

area reproducibilities over five days were determined. The calibration was determined at a low concentration range for the select alkanolamines (EA, DEA, TEA, and MDEA) and cations (sodium, ammonium, magnesium, and calcium) using triplicate injections of six standards from 0.5 to 25 mg/L. Additionally, a high concentration calibration was determined for the select alkanolamines (EA, DEA, TEA, and MDEA) from 50 to 1250 mg/L using triplicate injections of seven standards. Table 3 shows that the calibration results were best fit with quadratic equations and had coefficients of determination (r^2) >0.99.

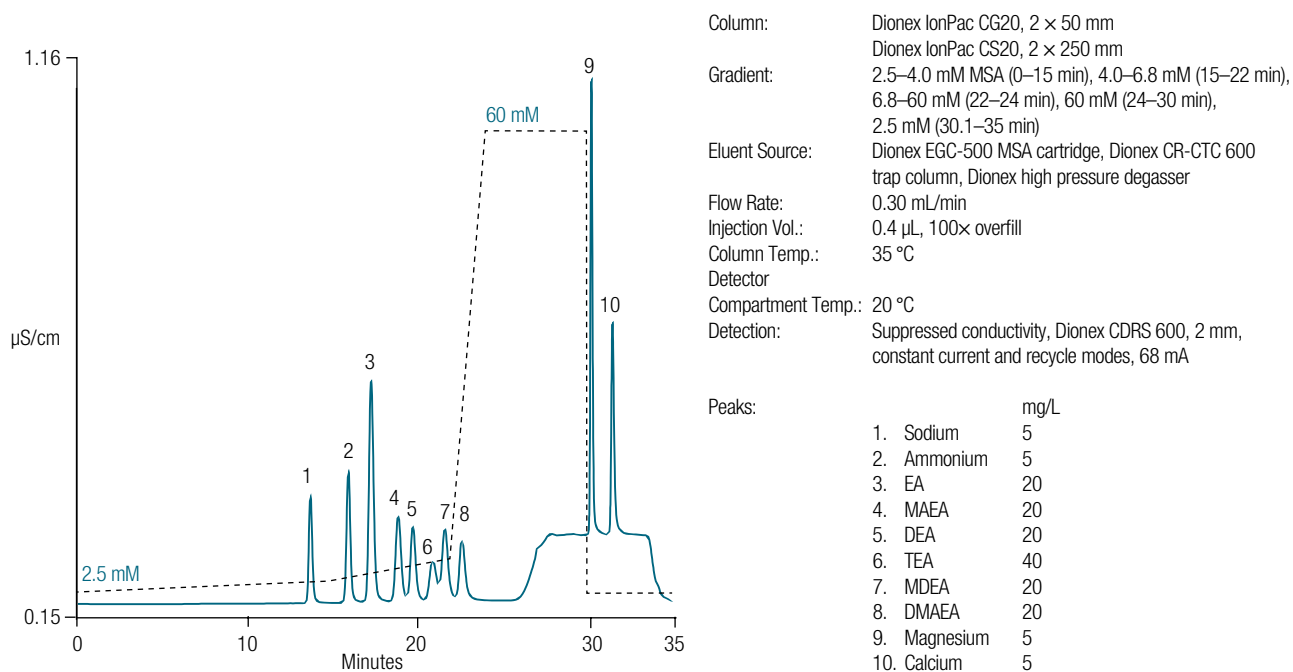

Figure 3. Cation and alkanolamine standard

Table 3. Summary of calibration range and MDL results

	Calibration Range (mg/L)	Type	Coefficient of Determination	MDL* (μ g/L)
Sodium	0.5–25	Quadratic	0.9997	26
Ammonium	0.5–25	Quadratic	0.9994	160
EA	0.5–25	Quadratic	0.9991	49
	50–1250	Quadratic	0.9998	--
DEA	0.5–25	Quadratic	0.9997	100
	50–1250	Quadratic	0.9996	--
TEA	0.5–25	Quadratic	0.9989	100
	50–1250	Quadratic	0.9979	--
MDEA	0.5–25	Quadratic	0.9993	52
	0–1250	Quadratic	0.9992	--
Magnesium	0.5–25	Quadratic	0.9978	2
Calcium	0.5–25	Quadratic	0.9926	3

*n = 7, MDL = SD x 3.14

The MDLs were determined using the standard deviation of $n = 7$ injections (low concentration calibration curve) times the Student's t -test constant. The alkanolamines and cations had MDLs ranging from 50 to 100 $\mu\text{g/L}$ and 2 to 160 $\mu\text{g/L}$, respectively.

To determine the column and method stability, a combined mixed standard (10 mg/L EA, DEA, MDEA, 40 mg/L TEA, 5 mg/L sodium, ammonium, magnesium, and calcium) was analyzed continuously over five days. Figures 4 and 5 show good reproducibilities, indicating that the Dionex IonPac CS20 column and this method are stable.

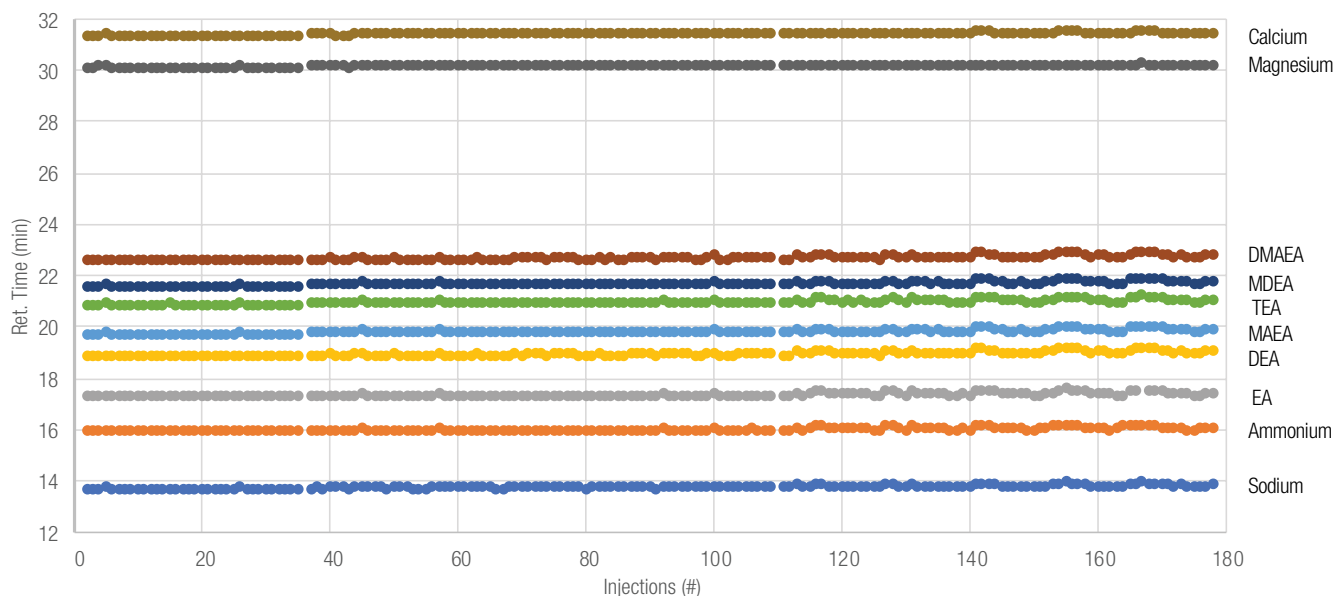

Figure 4. Retention time reproducibility of six alkanolamines and four cations over five days

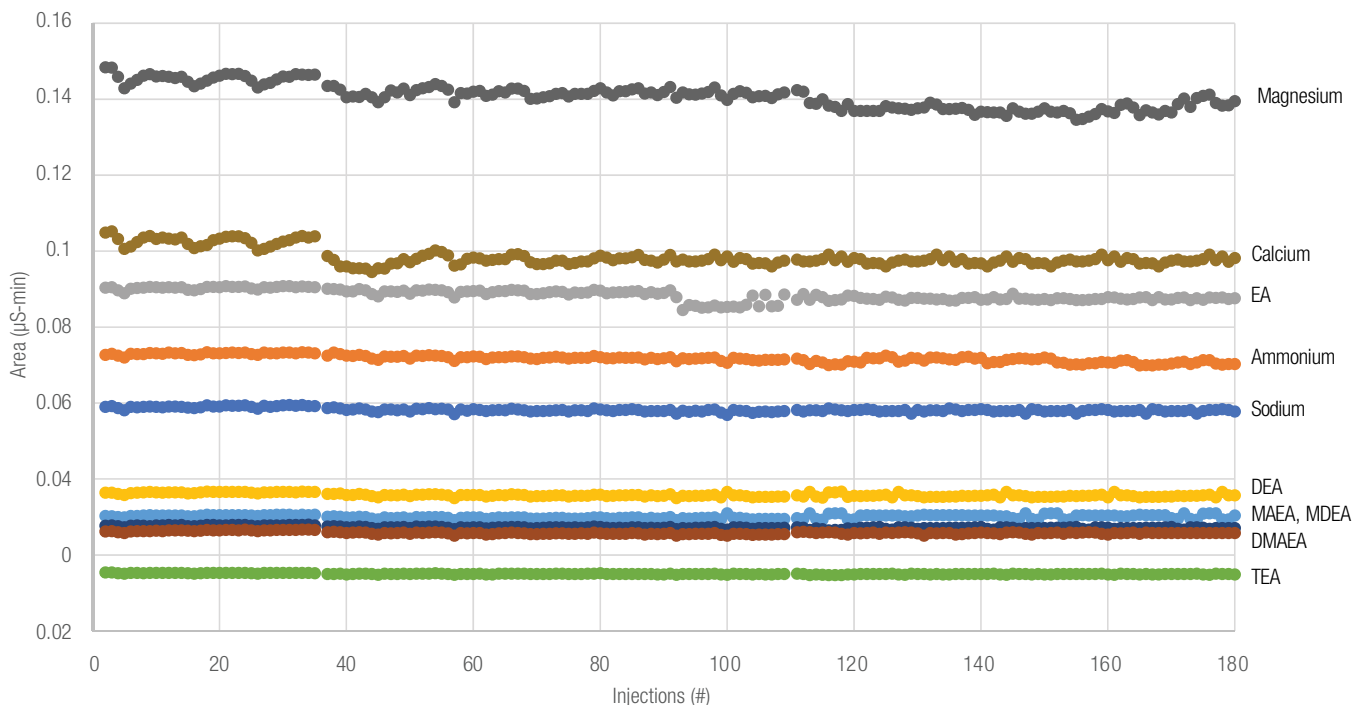

Figure 5. Peak area reproducibility of six alkanolamines and four cations over five days

The results summarized in Tables 4A and 4B show that the retention time RSDs were <0.4% per day over the five days. The peak area RSDs ranged from 0.1% to 2.0% per day, averaging 0.9% to 2.3% over the five days. Calcium and magnesium had the highest peak area RSDs.

Sample analysis and sample recoveries

The method was applied to 1000-fold diluted EA-, TEA-, and MDEA-based neutralizing amines samples. Figure 6 shows good chromatography of a 1000-fold diluted TEA-based neutralizing amine sample. Tables 5A and 5B show that the primary alkanolamine after 1000-fold dilution ranges from 900 to 2300 mg/L with lesser amounts of amines and cations, < LOD to 120 mg/L.

Table 4A. Retention time reproducibilities over five days

	Day 1		Day 2		Day 3		Day 4		Day 5		RSD
	RT (min)	RSD	RT (min)	RSD	RT (min)	RSD	RT (min)	RSD	RT (min)	RSD	
Sodium	13.68	0.06	13.71	0.15	13.74	0.12	13.77	0.33	13.82	0.47	0.46
Ammonium	15.91	0.06	15.95	0.14	15.98	0.12	16.0	0.32	16.06	0.45	0.45
EA	17.25	0.06	17.29	0.14	17.32	0.12	17.37	0.32	17.42	0.44	0.44
DEA	18.84	0.06	18.89	0.13	18.92	0.11	18.97	0.31	19.02	0.44	0.44
MAEA	19.71	0.06	19.75	0.13	19.79	0.11	16.84	0.30	19.89	0.41	0.42
TEA	20.86	0.05	20.91	0.12	20.94	0.10	20.99	0.28	21.04	0.39	0.40
MDEA	21.58	0.05	21.63	0.12	21.66	0.10	21.70	0.27	21.76	0.38	0.38
DMAEA	22.59	0.05	22.64	0.11	22.67	0.09	22.72	0.25	22.77	0.36	0.36
Magnesium	30.12	0.01	30.14	0.03	30.15	0.03	30.16	0.07	30.18	0.09	0.09
Calcium	31.36	0.02	31.38	0.03	31.40	0.04	31.42	0.08	31.44	0.11	0.12

Table 4B. Peak area reproducibilities over five days

	Day 1		Day 2		Day 3		Day 4		Day 5		RSD
	Area (μS-min)	RSD	Area (μS-min)	RSD	Area (μS-min)	RSD	Area (μS-min)	RSD	Area (μS-min)	RSD	
Sodium	0.059	0.5	0.058	0.59	0.058	0.49	0.058	0.49	0.059	0.53	0.90
Ammonium	0.073	0.4	0.072	0.58	0.071	0.39	0.713	0.95	0.071	0.99	1.30
EA	0.090	0.4	0.089	0.57	0.089	0.48	0.875	0.55	0.875	0.38	1.66
DEA	0.036	0.5	0.036	0.71	0.036	0.61	0.357	1.36	0.035	0.94	1.27
MAEA	0.030	0.5	0.030	0.71	0.030	0.61	0.303	1.68	0.030	1.75	1.54
TEA	0.015	0.5	0.015	0.58	0.015	0.61	0.149	0.83	0.015	0.51	0.97
MDEA	0.028	0.5	0.027	0.65	0.027	0.57	0.270	0.96	0.027	0.66	1.14
DMAEA	0.026	0.8	0.026	0.80	0.026	0.64	0.258	0.86	0.026	0.53	1.35
Magnesium	0.146	0.9	0.143	0.91	0.141	0.53	0.138	1.04	0.014	1.09	2.30
Calcium	0.102	1.2	0.098	2.0	0.097	0.73	0.198	0.73	0.097	0.75	2.50

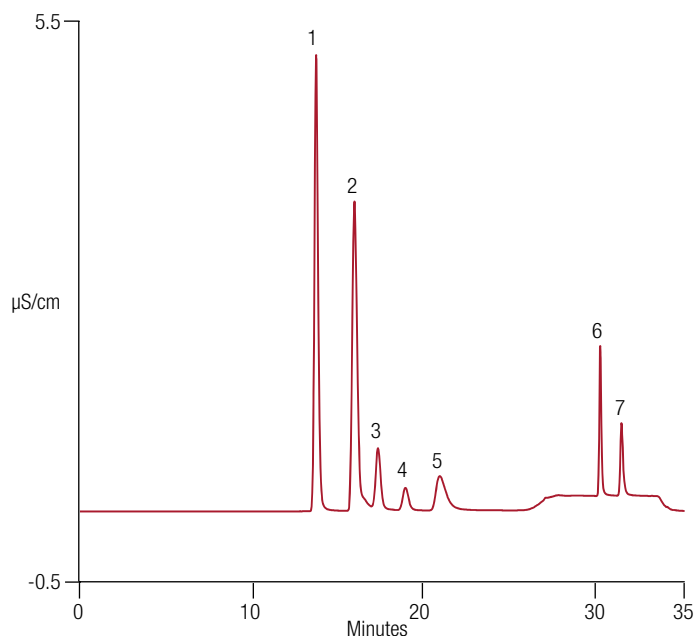

Column: Dionex IonPac CG20, 2 × 50 mm
 Dionex IonPac CS20, 2 × 250 mm
 Gradient: 2.5–4.0 mM MSA (0–15 min), 4.0–6.8 mM (15–22 min), 6.8–60 mM (22–24 min), 60 mM (24–30 min), 2.5 mM (30.1–35 min)
 Eluent Source: Dionex EGC-500 MSA cartridge, Dionex CR-CTC 600 trap column, Dionex high pressure degasser
 Flow Rate: 0.30 mL/min
 Injection Vol.: 0.4 µL, 100× overfill
 Column Temp.: 35 °C
 Detector
 Compartment Temp.: 20 °C
 Detection: Suppressed conductivity, Dionex CDRS 600, 2 mm, constant current and recycle modes, 68 mA

Peaks:

	mg/L
1. Sodium	186
2. Ammonium	194
3. EA	28.6
4. DEA	28.2
5. TEA	972
6. Magnesium	20.7
7. Calcium	30.7

Figure 6. 1000-fold diluted TEA-based scrubbing amine sample

Table 5A. Summary of cation determinations in 1000-fold diluted scrubbing amine samples

Sample (1000-fold Diluted)	Sodium (mg/L)	RSD	Ammonium (mg/L)	RSD	Magnesium (mg/L)	RSD	Calcium (mg/L)	RSD
EA-based	7.7	14.1	5.07	2.03	< LOD	1.34	< LOD	--
MDEA-based	5.72	3.82	10.5	0.81	< LOD	1.47	< LOD	--
TEA-based	186	1.17	194	1.27	20.7	1.63	30.7	2.46

Table 5B. Summary of alkanolamine determinations in 1000-fold diluted scrubbing amine samples

Sample (1000-fold Diluted)	EA (mg/L)	RSD	DEA (mg/L)	RSD	TEA (mg/L)	RSD	MDEA (mg/L)	RSD
EA-based	2741	1.34	ND	--	ND	--	ND	--
MDEA-based	26.5	1.47	26.6	0.51	--	--	1262	2.62
TEA-based	28.6	1.49	28.2	1.63	972	1.63	ND	--

Recoveries

To determine method accuracy, analyte recoveries were determined by measuring the diluted sample and diluted sample with an addition of a standard. To remain in the calibration ranges, the 1000-fold diluted samples were further diluted three-fold for the EA- and MDEA-based samples, and five-fold for the TEA-based sample.

Figure 7 shows the chromatograms of the 3000-fold

diluted MDEA-based neutralizing amine sample and the same sample with added standard (12 mg/L sodium, 15 mg/L ammonium, 3 mg/L magnesium, EA, DEA, and calcium, and 377 mg/L MDEA).

Tables 6A and 6B summarize the results, with good recoveries from 90% to 110%.

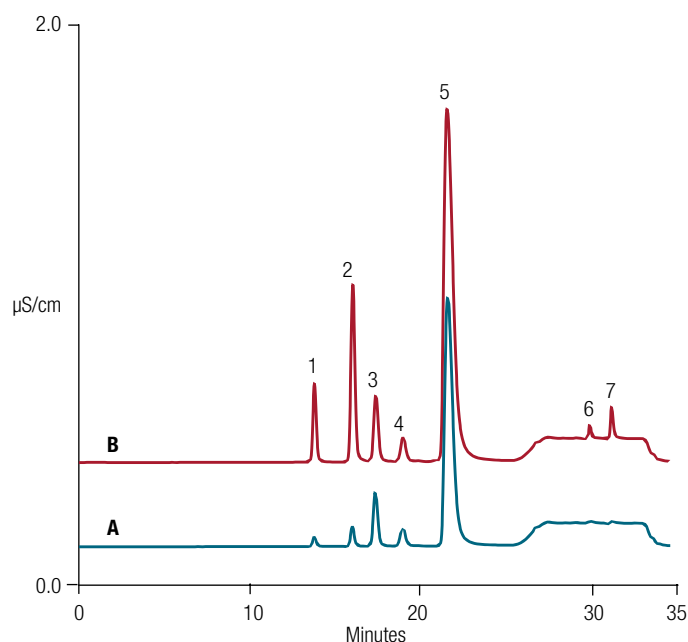

Column: Dionex IonPac CG20, 2 × 50 mm
 Dionex IonPac CS20, 2 × 250 mm
 Gradient: 2.5–4.0 mM MSA (0–15 min), 4.0–6.8 mM (15–22 min),
 6.8–60 mM (22–24 min), 60 mM (24–30 min),
 2.5 mM (30.1–35 min)
 Eluent Source: Dionex EGC 500 MSA cartridge, Dionex CR-CTC 600
 trap column, Dionex high pressure degasser
 Flow Rate: 0.30 mL/min
 Injection Vol.: 0.4 µL, 100× overfill
 Column Temp.: 35 °C
 Detector
 Compartment Temp.: 20 °C
 Detection: Suppressed conductivity, Dionex CDRS 600, 2 mm,
 constant current and recycle modes, 68 mA
 Sample Prep.: 3000-fold diluted with DI water for recovery experiments
 Samples:
 A: MDEA-based scrubbing amine
 B: Sample A + 12 mg/L sodium, 25 mg/L ammonium,
 3 mg/L magnesium, calcium, EA,
 and DEA, and 377 mg/L MDEA
 Peaks:

	A	B	
1. Sodium	2.2	14.0	mg/L
2. Ammonium	3.6	27.5	
3. EA	10.7	12.6	
4. DEA	9.6	12.1	
5. MDEA	405	736	
6. Magnesium	< LOD	2.0	
7. Calcium	< LOD	3.1	

Figure 7. Recovery of spiked standard in A) 3000-fold diluted MDEA-based scrubbing amine sample, B) Sample A with spiked standard

Table 6A. Recovery results of added cations into 1000-fold diluted scrubbing amine samples

Neutralizing amine*	Sodium			Ammonium			Magnesium			Calcium		
	Found (mg/L) / [RSD]	Added (mg/L)	Recovery (%)	Found (mg/L) / [RSD]	Added (mg/L)	Recovery (%)	Found (mg/L) / [RSD]	Added (mg/L)	Recovery (%)	Found (mg/L) / [RSD]	Added (mg/L)	Recovery (%)
3000-fold diluted EA-based	2.58 [1.2]	3.55	106	2.58 [1.2]	3.55	106	< LOD	--	--	< LOD	3.0	98.9
3000-fold diluted MDEA-based	2.15 [3.4]	11.7	101	3.43 [2.7]	25.7	109	< LOD	2.1	97.5	< LOD	3.1	97.8
5000-fold diluted TEA -based	38.8 [0.59]	9.55	96.3	38.5 [0.19]	20.7	92.8	4.89 [9.7]	1.59	94.5	6.13 [0.52]	9.67	108

Table 6B. Recovery results of added amines into 1000-fold diluted scrubbing amines samples

Neutralizing amine*	EA			DEA			TEA			MDEA		
	Found (mg/L) / [RSD]	Added (mg/L)	Recovery (%)	Found (mg/L) / [RSD]	Added (mg/L)	Recovery (%)	Found (mg/L) / [RSD]	Added (mg/L)	Recovery (%)	Found (mg/L) / [RSD]	Added (mg/L)	Recovery (%)
3000-fold diluted EA-based	920 [0.11]	370	97.1	< LOD	1.8	91.1	< LOD	2.3	108	< LOD	2.4	109
3000-fold diluted MDEA-based	10.7 [2.0]	2.6	94.7	9.6 [3.4]	2.6	98.0	< LOD	0.55	103	405 [0.4]	377	94.0
5000-fold diluted TEA -based	6.1 [0.47]	2.1	100	5.7 [0.37]	2.2	101	195.3 [0.2]	196	103	< LOD	--	--

*The 1000-fold neutralizing amine samples were further diluted 3-fold (EA, MDEA) and 5-fold (TEA) for these experiments prior to analysis and to adding the standard.

Conclusion

This application using the Dionex IonPac CS20 column provides an alternative method to determine cations and alkanolamines in amine neutralizing samples. The Dionex IonPac CS20 cation-exchange column has optimized selectivity for monovalent (Group I) cations resulting in an elution window for the alkanolamines of interest between the Group I and Group II cations. Four cations and six alkanolamines at concentrations ranging from <1 mg/L to 2500 mg/L were determined accurately in 1000-fold diluted amine neutralizing solutions.

This application and other applications related to amine neutralizing samples can be found in Thermo Scientific AppsLab Library of Analytical Applications.²¹

References

1. International Energy Agency. Key word statistics, IEA Publications, November 2018. [online] <https://www.eia.gov/todayinenergy/detail.php?id=36292> (accessed May 2019.)
2. Sulfide-producing bacteria dominate hydraulically fractured oil and gas wells, Phys.org, July 5, 2017. <https://phys.org/news/2017-07-sulfide-producing-bacteria-dominate-hydraulically-fractured.html> (accessed May 2019.)
3. Amine Scrubbing Solutions, Global CCS Institute. [Online] <https://hub.globalccsinstitute.com/publications/final-report-project-pioneer/amine-scrubbing-process> (accessed May 2019.)
4. Processing Natural Gas, NaturalGas.org. [Online] <http://naturalgas.org/naturalgas/processing-ng/> (accessed May 2019.)
5. Rooney, P.C.; Bacon, T.R.; DuPart, M.S. Effect of Heat Stable Salts on MDEA Corrosivity, Parts 1 and 2. *Hydrocarbon Processing*, **1996**, Mar, 95–103; **1997**, Apr, 65–71.
6. Thermo Fisher Scientific. Dionex Application Note 138: Determination of Thiosulfate in Refinery and Other Wastewaters. Sunnyvale, CA, USA. 2001. [Online] <https://appslab.thermofisher.com/App/1415/an-138-determination-thiosulfate-refinery-otherwastewaters>. (accessed May 2019.)
7. Thermo Fisher Scientific. Dionex Technical Note 122: Separation of Heat Stable Amine Salts in Methyl-diethanolamine (MDEA) Solutions. Sunnyvale, CA, USA. 2013. [Online] <https://appslab.thermofisher.com/App/1664/tn122-separation-heat-stable-amine-salts-methyl-diethanolamine-mdea-solutions-using-high-pressure-ic> (accessed May 2019.)
8. Thermo Scientific Application Note AN72622: Fast Separation of Heat Stable Salts, 2018, Sunnyvale, CA, USA. [Online] <https://assets.thermofisher.com/TFS-Assets/CMD/Application-Notes/an-72622-ic-fast-separation-heat-stable-salts-an72622-en.pdf> (accessed May 2019)
9. Thermo Scientific Application Update AU126 Determination of Diethanolamine and Triethanolamine in Surface Finishing, Wastewater and Scrubber Solutions, 2014, Sunnyvale, CA, USA. [Online] <https://assets.thermofisher.com/TFS-Assets/CMD/Application-Notes/AU-126-IC-Diethanolamine-Triethanolamine-Wastewater-AU71356-EN.pdf> (accessed May 2019.)
10. Thermo Scientific Application Update AU138: Determination of Ethanolamines in Industrial Waters by Cation-Exchange Chromatography, 1998, Sunnyvale, CA, USA. [Online] https://tools.thermofisher.com/content/sfs/brochures/4241-AU138_LPN0995-01.pdf (accessed May 2019.)
11. Thermo Scientific Application Note AN72609 Using ion chromatography with electrospray ionization mass spectrometry for the determination of cations and amines in alkanolamine scrubbing solutions, 2018, Sunnyvale, CA, USA. <https://assets.thermofisher.com/TFS-Assets/CMD/Application-Notes/an-72609-ic-ms-alkanolamine-scrubbing-solutions-an72609-en.pdf> (accessed May 2019.)
12. Thermo Scientific Product Specification: Dionex IonPac CS20 Column, 2018, Sunnyvale, CA, USA. [Online] <https://assets.thermofisher.com/TFS-Assets/CMD/Specification-Sheets/ps-72595-ionpac-cs20-cation-exchange-columns-ps72595-en.pdf>. (accessed May 2019)
13. ASTM Specification D 5127, ASTM International. 100 Barr Harbor Drive, West Conshohocken, PA 19428.
14. Thermo Scientific Operator's Manual: Dionex Integriion HPIC system, 2016, Sunnyvale, CA, USA. [online] <https://assets.thermofisher.com/TFS-Assets/CMD/manuals/Man-22153-97003-IC-Integriion-Man2215397003-EN.pdf>
15. Thermo Scientific Technical Note TN175 Configuring the Dionex Integriion HPIC System for High-Pressure Reagent-Free Ion Chromatography, 2016, Sunnyvale, CA, USA. [Online] <https://assets.thermofisher.com/TFS-Assets/LSG/Application-Notes/TN-175-IC-Configuring-Integriion-RFIC-TN1751961-EN.pdf> (accessed May 2019.)
16. Thermo Scientific Product Manual: Dionex Eluent Generator Cartridges, 2018, Sunnyvale, CA, USA. [online] <https://assets.thermofisher.com/TFS-Assets/CMD/manuals/Man-065018-Eluent-Generator-Cartridge-MAN065018-EN.pdf> (accessed May 2019.)
17. Thermo Scientific Product Manual: Continuously Regenerated Trap columns (CR-TC 500, CR-TC 600, Capillary), 2018, Sunnyvale, CA, USA. [Online] <https://assets.thermofisher.com/TFS-Assets/CMD/manuals/Man-079684-Continuously-Regenerated-Trap-CR-TC-Man079684-EN.pdf> (accessed May 2019.)
18. Thermo Scientific Product Manual: Dionex IonPac CS20 Column, 2018, Sunnyvale, CA, USA. [Online] <https://assets.thermofisher.com/TFS-Assets/CMD/manuals/Man-065716-IC-IonPac-CS20-Man065716-EN.pdf>
19. Thermo Scientific DRS 600, ERS 500e and ERS 500 Carbonate Suppressor Installation Checklist. Included in the suppressor box. November 2018.
20. Thermo Scientific Product Manual: Dionex DRS 600 Suppressor, Dionex ERS 500e Suppressor, Dionex ERS 500 Carbonate Suppressor, 2018, Sunnyvale, CA, USA. [Online] <https://assets.thermofisher.com/TFS-Assets/CMD/manuals/man-031956-dionex-suppressors-man031956-en.pdf> (accessed May 2019.)
21. Thermo Scientific AppsLab Library of Analytical Applications. <https://appslab.thermofisher.com>

Find out more at [thermofisher.com/IC](https://www.thermofisher.com/IC)