



"What's inside your car?"

Car interior emissions testing using Thermal desorption GC/MS analysis



Inge de Dobbeleer
EU GCMS specialist
ThermoFisher
Lara Kelly
Sales Manager
Markes



● ***Thermal desorption***



The Thermal Desorption Process

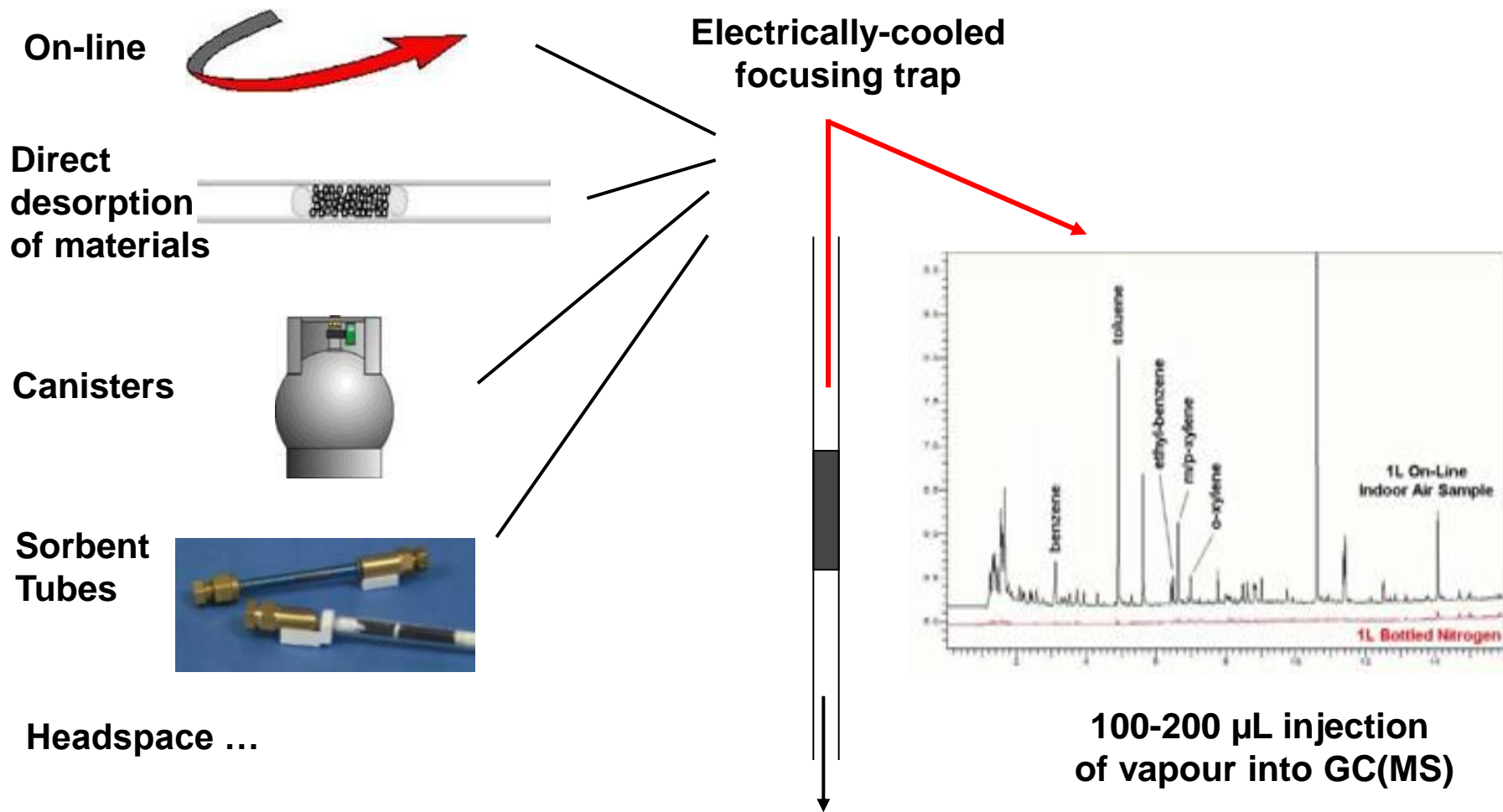

What can be analysed by TD?

Yes

- VOC / SVOC
 - C₂ to n-C₄₀ (b.p. <500°C),
 - GC analysis
 - Matrix compatible with high temperatures required

No

- Compounds which are not compatible with standard gas chromatography
- CH₄
- > n-C₄₀ (non-volatiles)
- Special GC analysis, *e.g.* on-column injection
- Most inorganic (permanent) gases (O₂, O₃, CO₂, SO₂, NO₂, *etc.*
Exceptions include H₂S, N₂O & SF₆)

Thermal desorption (TD) instruments

TD sampling accessories/consumables



Autosampler and Sample tubes



DiffLok™ - Caps

Sample Tubes (Glass)

Standard-Tubes (Tenax)



Electrically-cooled focusing trap

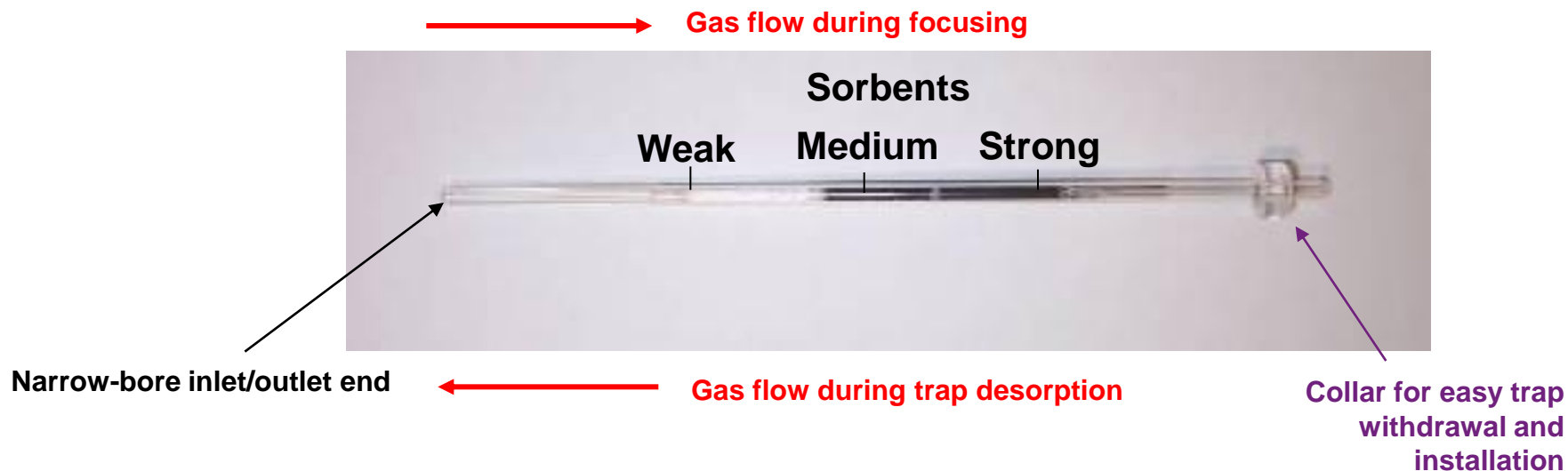

- ✓ Inert and high thermal conductivity
- ✓ Maximum trapping efficiency: -30°C & 4 sorbents
- ✓ Simultaneous VOC & SVOC analysis
- ✓ Maximum sensitivity
- ✓ Reduces analytical interference

Stage 1: Primary (tube) desorption with optional (inlet) split

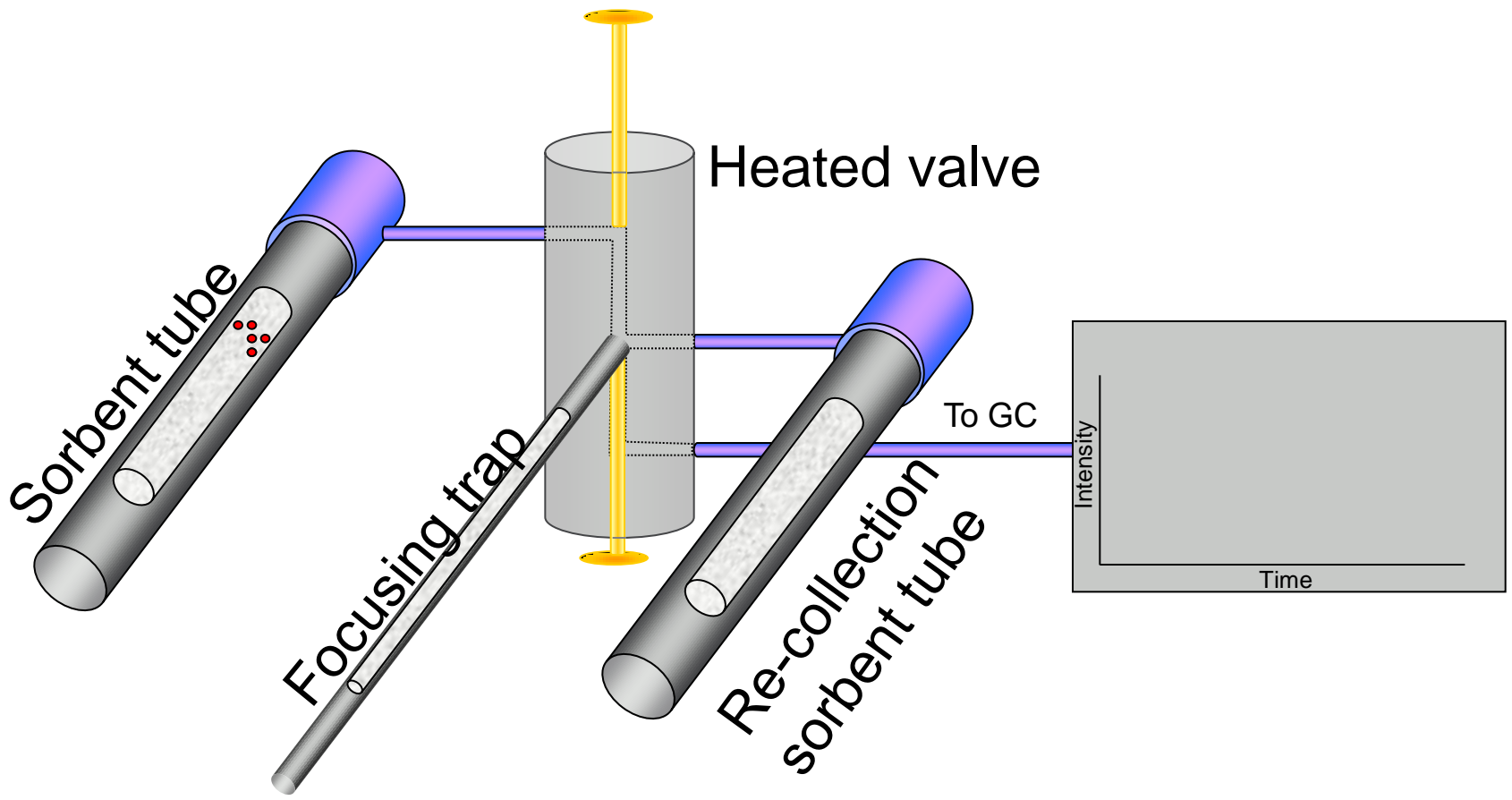

Stage 2: Secondary (trap) desorption with optional (outlet) split

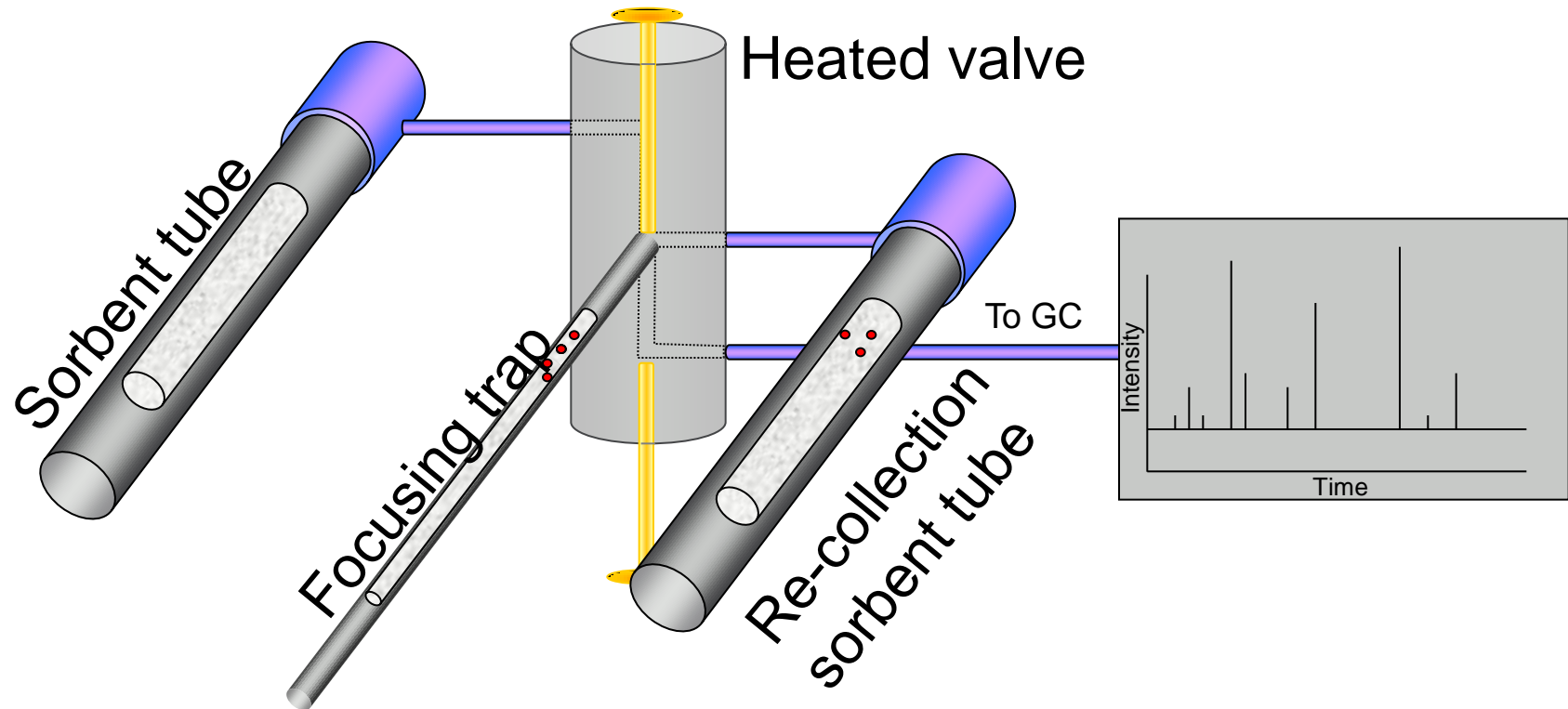

Advantages of Markes TD

- All applications on one platform – **C₂ to n-C₄₀ AND reactive compounds** plus high and low concentrations - means versatility
- **Cryogen-free** cooling – reliability and low running costs
- **Capacity and versatility** – up to 100 tubes plus up to 8 cans or online means high capacity and fast return on investment
- **SecureTD-Q** as standard for repeat analysis and validation
- **ECC** and optional electronic mass flow control of TD split/desorb flows
- Splitless operation with high res. capillary for **optimum sensitivity**
- Optional **tube tagging** for enhanced tube and sample tracability
- Uniquely **effective tube seals** for TD automation offering simple/robust automation
- Standard **method compliant**: leak test, purge to vent, backflush trap..

● **ISQ**



● The world leader in serving science

The ISQ: single quad MS

Heated source: ion volume, repellor, lenses, RF prefilter

Solid, highly inert material ensures reliable performance in all ionization modes, including EI and CI

Dual filament cartridge

Two filaments in same magnetic orientation

Filament lens assures that both filaments will remain protected, for longer life even with redundancy

The S-Shaped Ion Guide

Reduces neutral noise created by excited helium neutrals striking the detector, resulting in lower detection limits and better selectivity

Autotune:

Complete and standardized autotune algorithm for excellent day to day variability

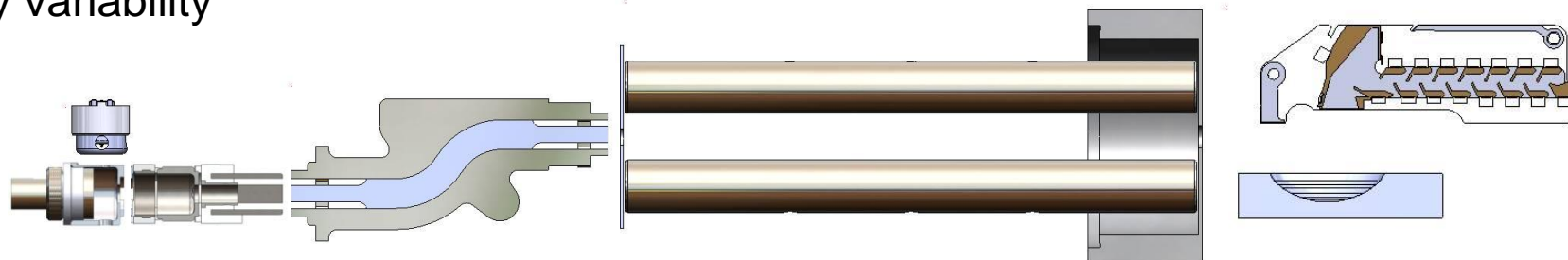
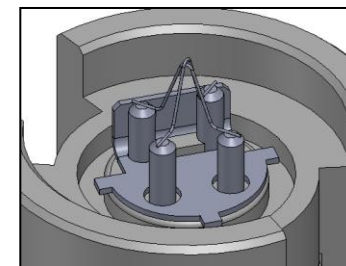
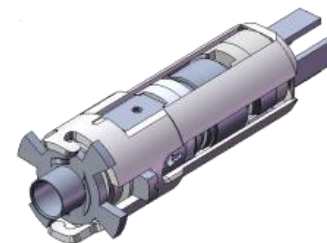

Maintenance without venting and without wires

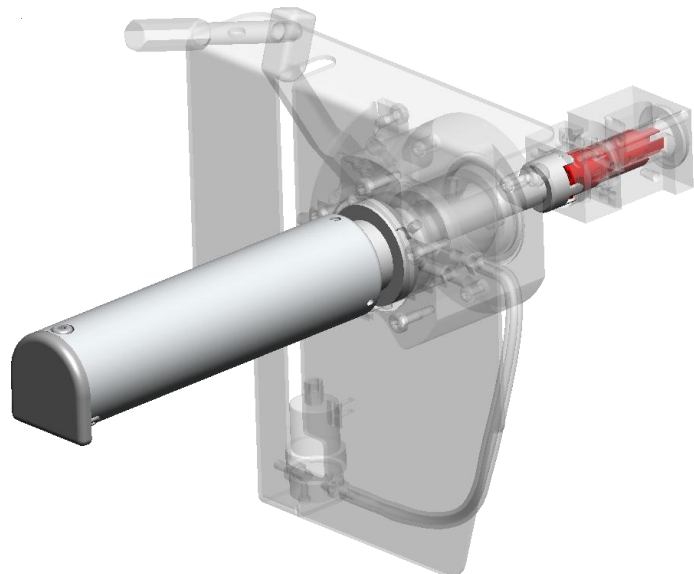

Step 1. Insert removal tool

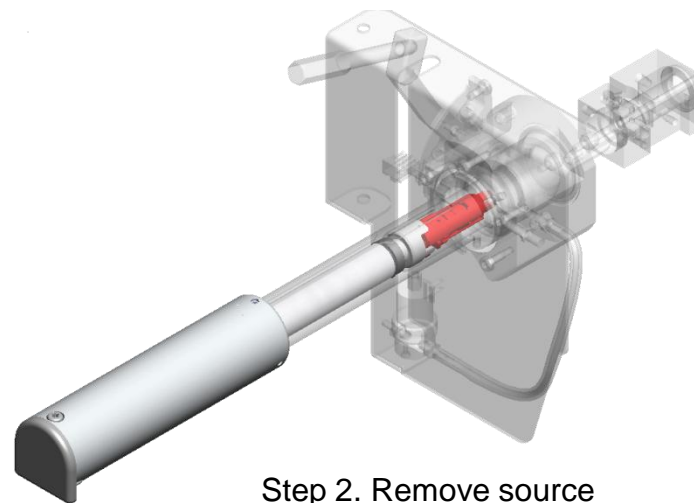

Step 2. Remove source

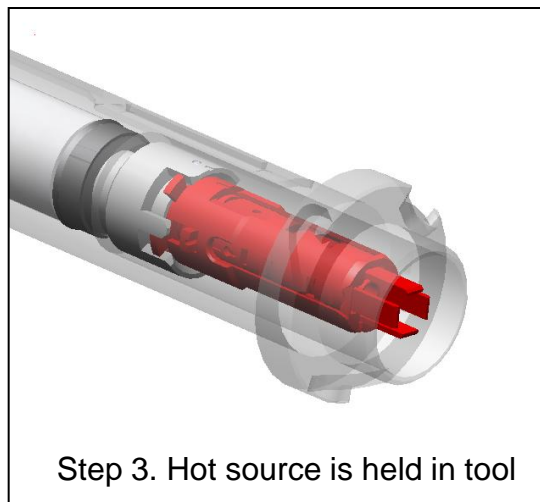

Step 3. Hot source is held in tool

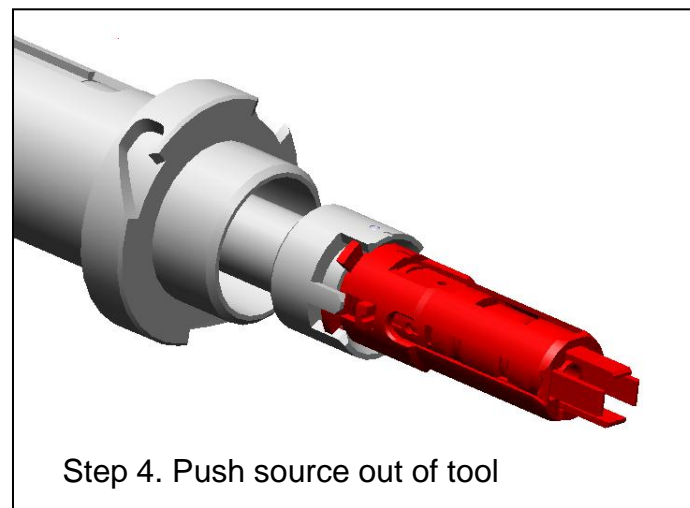

Step 4. Push source out of tool

The ISQ: True Fast scanning

<u>Theoretical (scan/sec)</u>	<u>Actual (scans/sec)</u>
9.62	9.67
18.52	18.58
35.00	35.00
70.13	70.00

d:\training\fs2802
 new 1pgOFN, at scan rate 2500 amu/s, factory spec
 RT: 3.502 - 3.753 SM: 5B

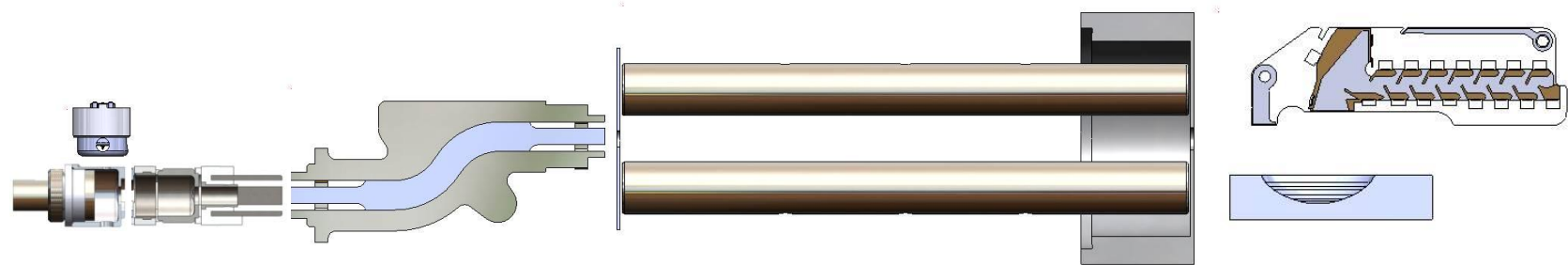
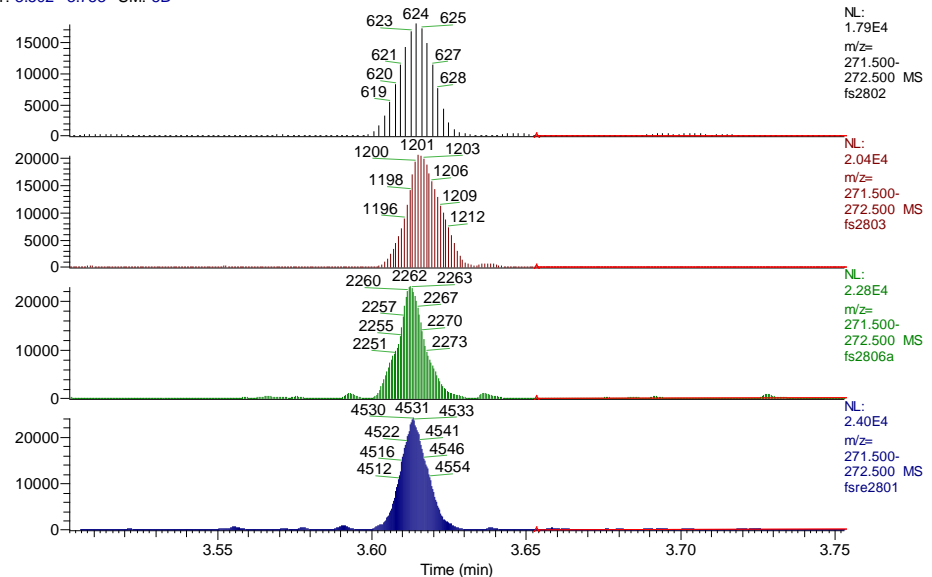

FS and SIM simultaneous

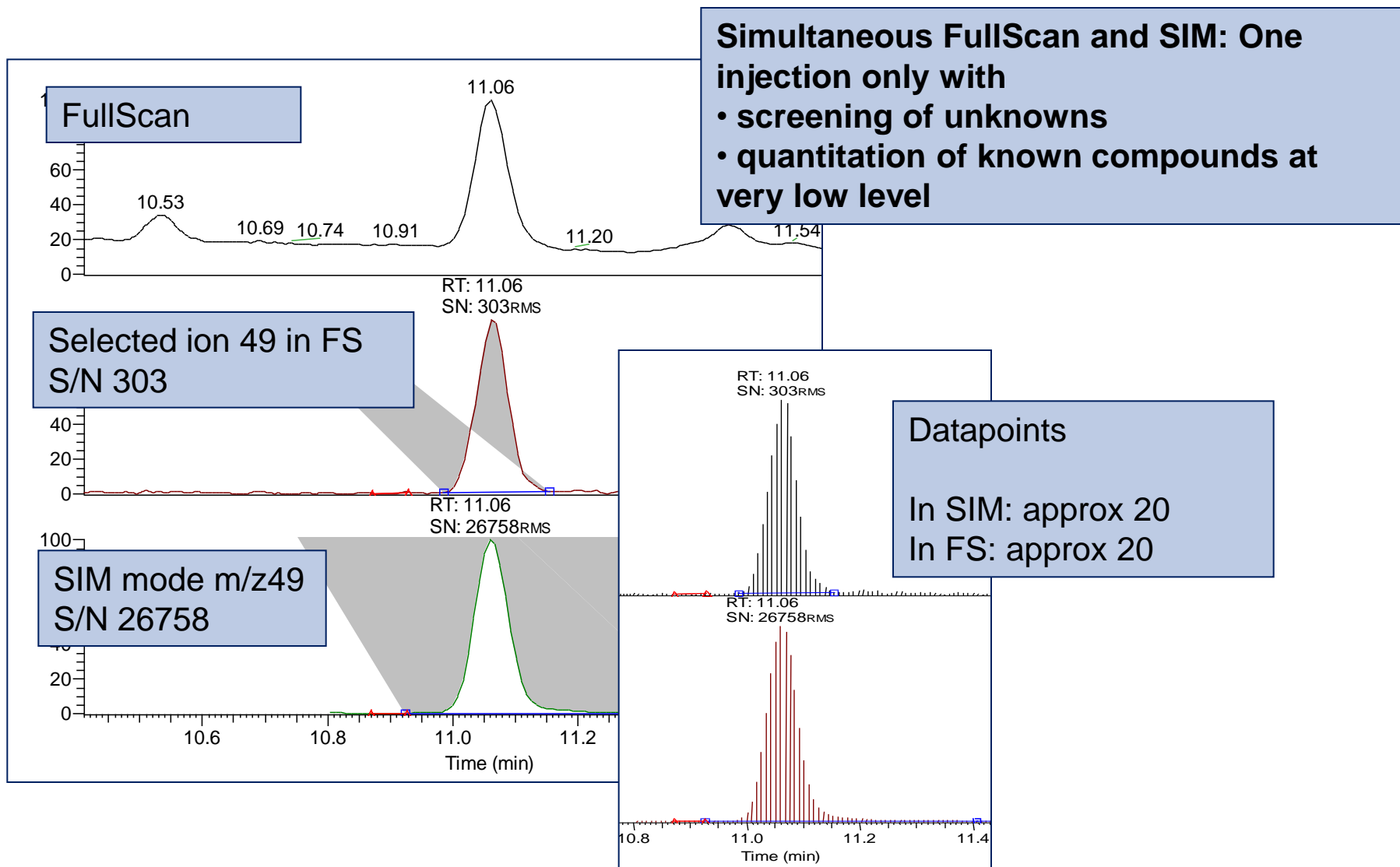

● ***Rules and regulations***



German regulations

VDA

Verband der
Automobilindustrie



- Voluntary program (at the moment) for Auto manufacturers as set up by the German automotive industry (**VDA**)
- Cabin air quality must adhere to quality guidelines
 - VDA 270 - Odour
 - VDA 275 - Formaldehyde
 - VDA 276 - VOC, s-VOC Test Chamber
 - VDA 277 - VOC Headspace
 - VDA 278 - VOC, s-VOC Direct desorption
- The list of target compounds and specified concentration limits defined by TÜV (Technischer Überwachungs-Verein Nord)

Japanese regulations



JAMA's Japanese Automotive Manufacturers Association:

New models of passenger cars to be sold from fiscal **2007** must satisfy the **indoor concentration guidelines established for 13 VOCs** by the Ministry of Health, Labour and Welfare.

Each carmaker must continuously **strive to reduce VOC concentration in passenger compartments**. Vehicles covered by the guidelines are passenger **cars manufactured and sold domestically**.

JAMA and TÜV Guidelines



JAMA Standard	
Substance Name	Indoor Concentration Guideline Value,* $\mu\text{g}/\text{m}^3$
Formaldehyde	100
Toluene	260
Xylene	870
Paradichlorobenzene	240
Ethyl benzene	3800
Styrene	220
Cholorpyrifos	1 / (0.1 children)
Di-n-butyl phthalate	220
Di-2-ethylhexyl phthalate	330
Tetradecane	220
Diazinon	0.29
Acetaldehyde	48
Fernobucard	33

TUV Standard	
Substance/Class	Limit Value w/out air exchange, $\mu\text{g}/\text{m}^3$
Formaldehyde	60
BTEX (except benzene)	200
Benzene	5
Styrene	30
Halogenated hydrocarbons	10
Esters and Ketones	200
Aldehydes (except Formaldehyde)	50
Alcohols	50
Glycol-ethers-esters	100
Nitrosamines	1
Amines	50
Phenoles	20
Phthalates	30

American regulations



- Manufacturer specific
- Joint ventures between some manufactures
- Limit of compounds taken from California's
OEHHA list
- Test chambers

OEHHA
Office of Environmental Health Hazard Assessment

Chronic Reference Exposure Level (REL)s



Table 4-1 Target CREL VOCs and their maximum allowable concentrations

No.	Compound Name	CAS No.	Allowable Conc. ^a ($\mu\text{g}/\text{m}^3$)
1	Acetaldehyde	75-07-0	70
2	Benzene	71-43-2	30
3	Carbon disulfide	75-15-0	400
4	Carbon tetrachloride	56-23-5	20
5	Chlorobenzene	108-90-7	500
6	Chloroform	67-66-3	150
7	Dichlorobenzene (1,4-)	106-46-7	400
8	Dichloroethylene (1,1)	75-35-4	35
9	Dimethylformamide (N,N-)	68-12-2	40
10	Dioxane (1,4-)	123-91-1	1,500
11	Epichlorohydrin	106-89-8	1.5
12	Ethylbenzene	100-41-4	1,000
13	Ethylene glycol	107-21-1	200
14	Ethylene glycol monoethyl ether	110-80-5	35
15	Ethylene glycol monoethyl ether acetate	111-15-9	150
16	Ethylene glycol monomethyl ether	109-86-4	30
17	Ethylene glycol monomethyl ether acetate	110-49-6	45
18	Formaldehyde	50-00-0	16.5 ^b
19	Hexane (n-)	110-54-3	3,500
20	Isophorone	78-59-1	1,000
21	Isopropanol	67-63-0	3,500
22	Methyl chloroform	71-55-6	500
23	Methylene chloride	75-09-2	200
24	Methyl <i>t</i> -butyl ether	1634-04-4	4,000
25	Naphthalene	91-20-3	4.5
26	Phenol	108-95-2	100
27	Propylene glycol monomethyl ether	107-98-2	3,500
28	Styrene	100-42-5	450
29	Tetrachloroethylene	127-18-4	17.5
30	Toluene	108-88-3	150
31	Trichloroethylene	79-01-6	300
32	Vinyl acetate	108-05-4	100
33-35	Xylenes, technical mixture (m-, o-, p-xylene combined)	108-38-3, 95-47-6, 106-42-3	350

- a) Refer to http://www.oehha.ca.gov/air/chronic_rels/AllChrels.html. All maximum allowable concentrations are one-half the corresponding CREL adopted by Cal/EPA OEHHA with the exception of formaldehyde. For any future changes in the CREL list by OEHHA, values in Table 4.1 shall continue to apply until these changes are published in the Standard Method.
- b) Formaldehyde has a CREL of $9 \mu\text{g}/\text{m}^3$ (December 2008); guidance value established by this Standard Method at $16.5 \mu\text{g}/\text{m}^3$ before Dec 31st, 2011 and at $9 \mu\text{g}/\text{m}^3$ starting from Jan 1st, 2012. See Section 4.3.2.

OEHHA

Office of Environmental Health Hazard Assessment

Harmonisation: Regulations and Methods

ISO 12219 Indoor Air of Road Vehicles

ISO 12219-1 Whole vehicle test chamber -Specification and method for the determination method for the determination of volatile organic compounds in car interiors

ISO 12219-2 Determination of the emissions of volatile organic compounds from car trim components –**Bag method (Screening method)**

ISO 12219-3 Determination of the emissions of volatile organic compounds from car trim components –**Micro-chamber method**

ISO 12219-4 Determination of the emissions of volatile organic compounds from car trim components –**Small chamber method**

Methods

External - Certification

VOC emission profiles under 'real-use' conditions are best obtained using test chambers or cells with sorbent tube sampling and TD-GC(-MS) analysis.



Internal QC - Prevention

Direct thermal desorption / thermal extraction of materials - Measures VOC content as an indication of emission potential



ISO 12219-3 Determination of the emissions of volatile organic compounds from car trim components – Micro-chamber method

- **Surface-only** or **bulk** emissions testing
- **4 or 6 samples/hour**
- Sorbent tubes ((S)VOC) or DNPH cartridges (H₂CO)
- Parameters:
 - 65 °C
 - equilibrate for 20 minutes.
 - 50 ml/min (VOCs) or 250 ml/min (H₂CO)
 - Collect vapour for 15 minutes (VOC) or for 2-4 hours (H₂CO)



* UK patent application 0501928.6



Using the microchamber for bulk/content testing

Bulk Emissions

- Ambient/elevated temperature
- Dynamic Headspace
- Homogenous sample

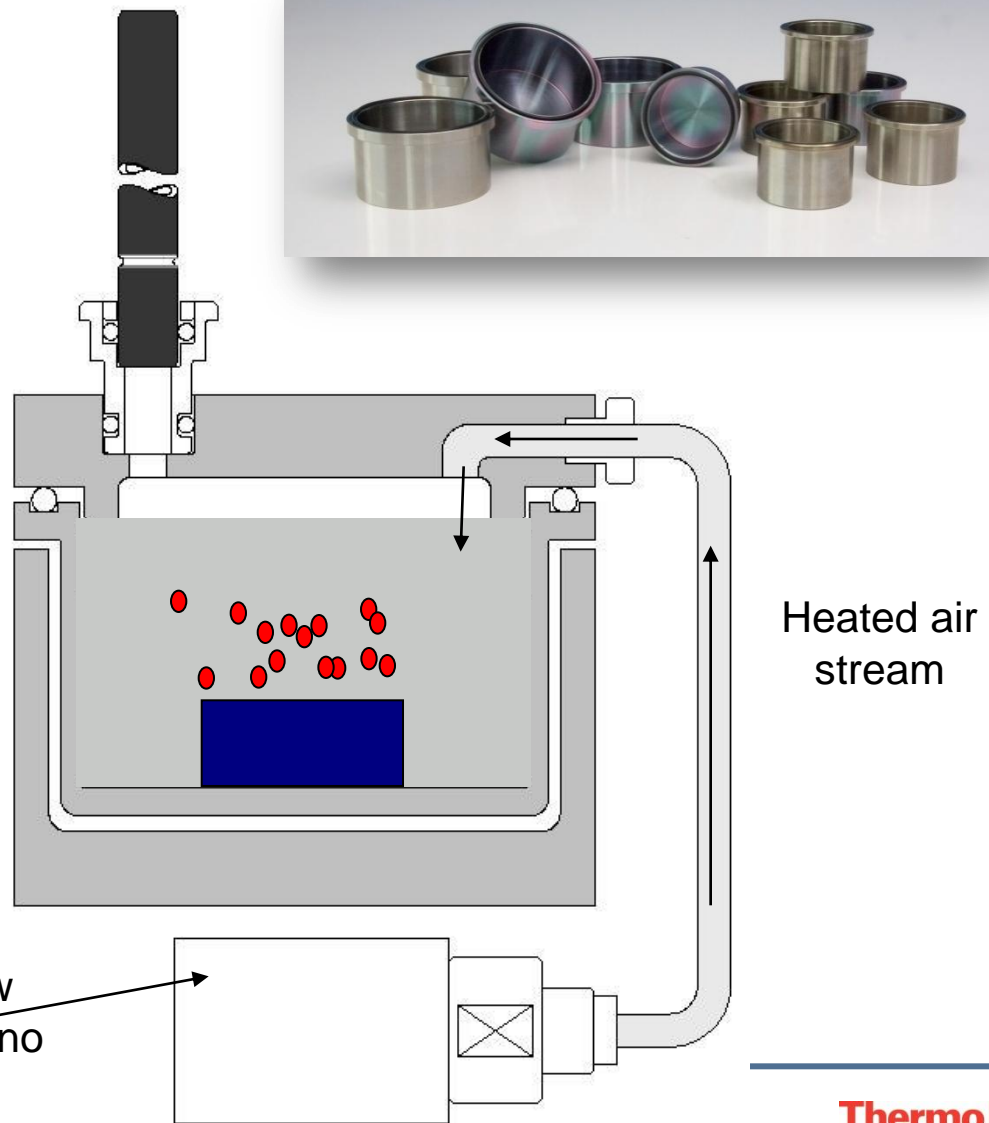

Proprietary flow control device – no pump required

Surface emissions

Heated lid: The collar projecting from lid defines area for surface-only emission testing and minimises ingress of edge emissions

Sample tube

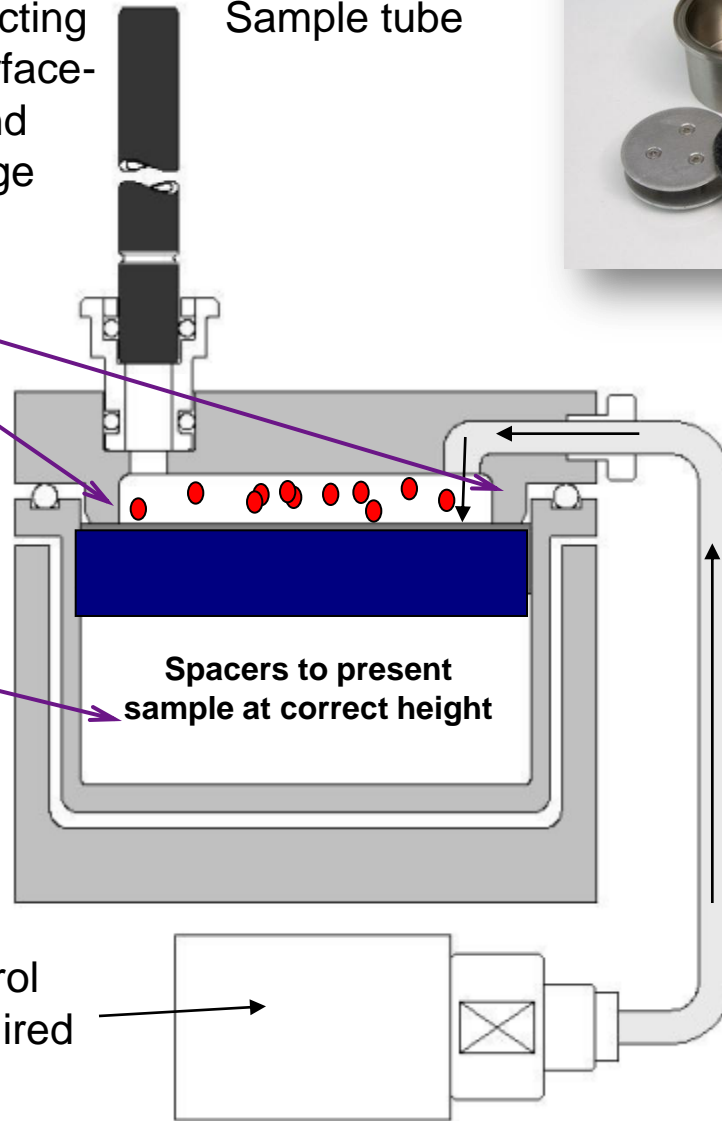

Heated air stream

Proprietary flow control device – no pump required

Micro-chamber data has been shown to correlate with results from

Correlation Studies

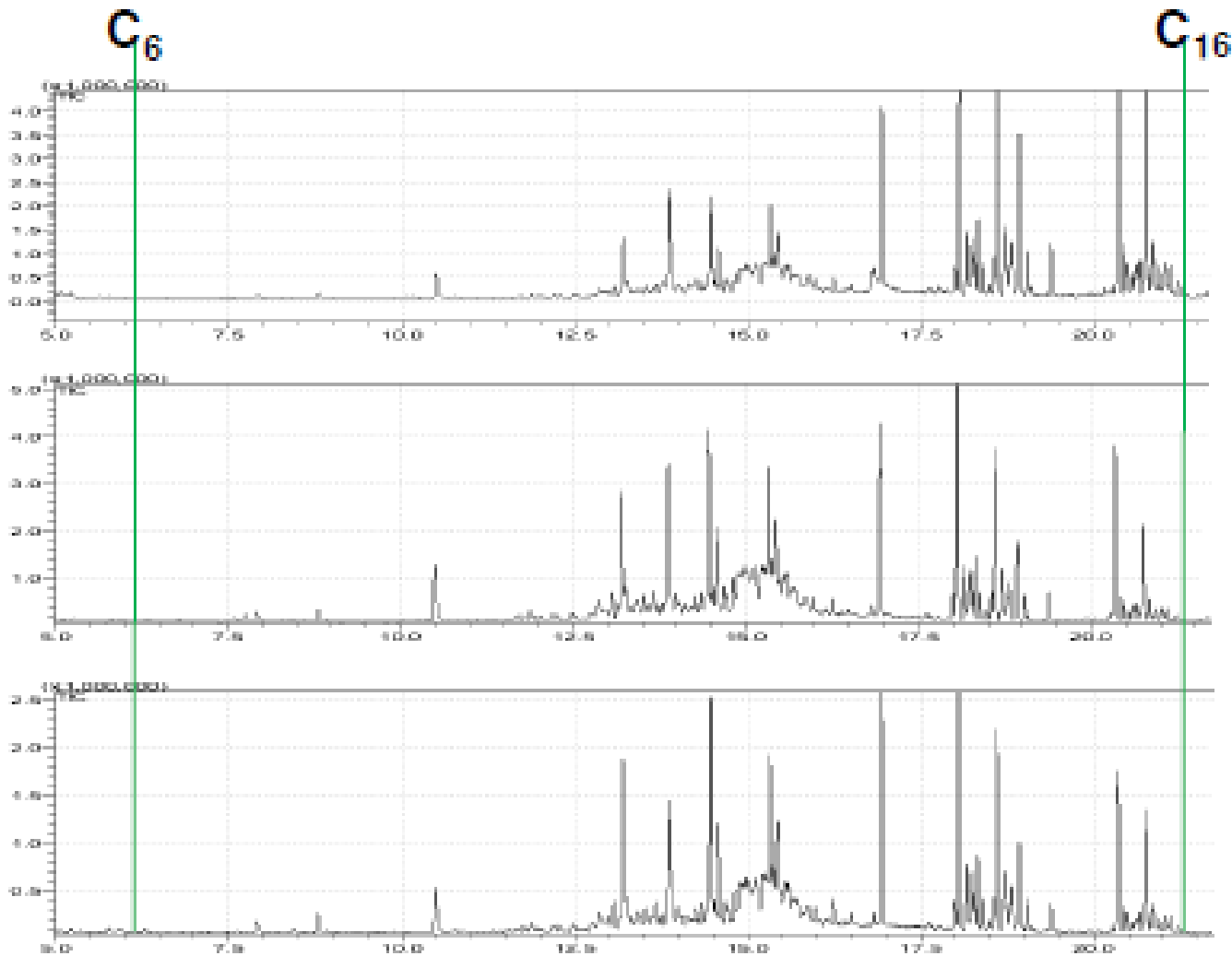

Small
chamber -
Days

Tedlar
bag -
Hours

Microcham
ber -
Minutes

Micro-chamber emission screening methods are now being
standardised

● ***The 'new car' smell***



Trace ISQ and Markes TD-100

T-line

Autosampler

Desorber

ISQ: single quad MS

TraceGC

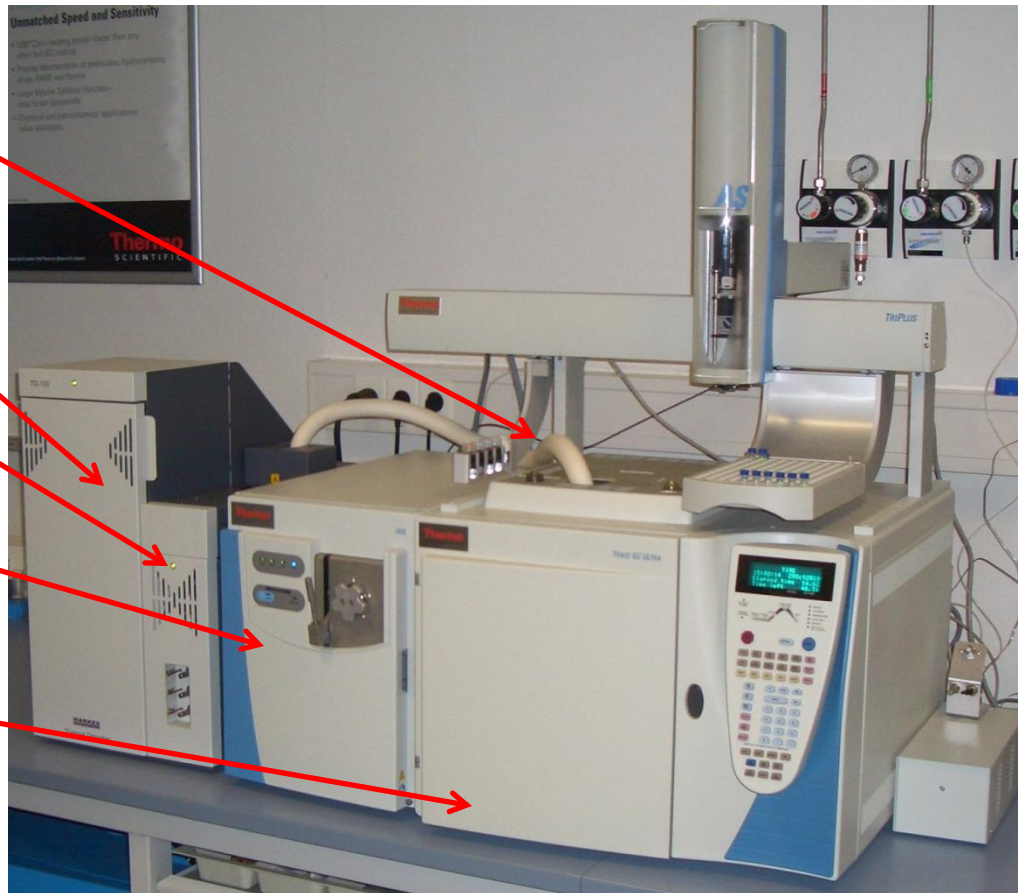

Analysis Goal

- **The analysis procedure serves to identify the emissions from non-metallic materials that are used in Automobiles. For example:**
 - **Textile**
 - **Carpets**
 - **Adhesives**
 - **Sealants**
 - **Foams**
 - **Leather**
 - **Plastics**
 - **Transparancies**
 - **Paint**
 - **Combination Materials**



Description of the method- VOC

- The samples are thermally extracted and the emissions analyzed using **GC/MS**
- There are two half-quantitative summation values determined that determine the emission levels for
 - volatile organic compounds (**VOC-Value**) and
 - The portion of condensable substances (**Fogging-Value**)
- The VOC value according to VDA 278 is the sum of high to medium volatile substances and is reported as toluene equivalent results. Substances with vapor point or retention times for substances up to Eicosan (C20) are determined and reported.
 - The sample is analyzed for 30 minutes at 90°C

Description of the method determination- Fogging

- The Fog value is the sum of the heavy volatile substances that occur after the elution time for n-Hexadecane. This will be reported as the Hexadecane equivalents.
 - These are the substances in vapor pressure range from n-Alkanes „C16“ up to „C32“ are reported
 - These substances can condensate at slightly warmer than room temperatures and can be seen as “Fog Film” on the inside portion of windshields



Sample Preparation TDS



z.B. ca 10mg Leder

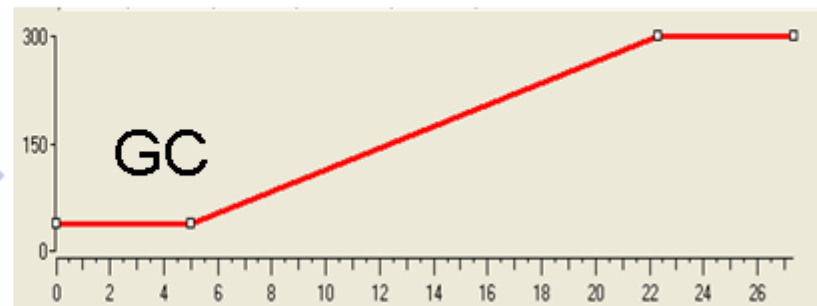
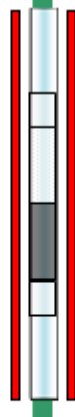
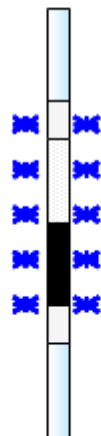
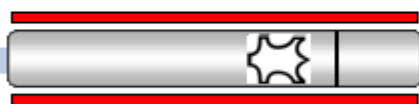

Extraktion:

1.: VOC: 30
Minuten bei 90°C

2.: Fog: 60 Minuten
bei 120°C

Desorption der
Kühlfalle:

3 Minuten bei
300°C

Instrument parameters

- **Trace GC**

- Column: TR 5 ms, 30m x 0.25m x 0.25 μ m
- Oven: 40°C – 2min – 3°C/min – 92°C – 0min- 5°C/min – 160°C – 0min- 10°C/min – 280°C – 10min
- Carrier: 1.5 mL/min He, const. Flow

- **ISQ MS**

- EI-Scan: m/z 29 – 370 w. 200ms / Scan

- **TDS 100**

- Flow Path: 200°C
- Desorption:
 - 30 min at 90°C (VOC)
 - 60 min at 120°C (FOG)
- Split (high): Desorption: 4,2:1; Injektion: 27:1; Gesamt: 113:1
- Split (low): Desorption: 2,1:1; Injektion: 15,6:1; Gesamt: 32,8:1
- Trap: 2-stage graphitised carbon
- Trap low Temp: -30°C; Trap high Temp: 300°C for 3 minutes

Standard Loading Rig



C-SLR

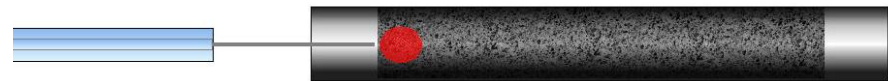

Direct injection of liquid standard

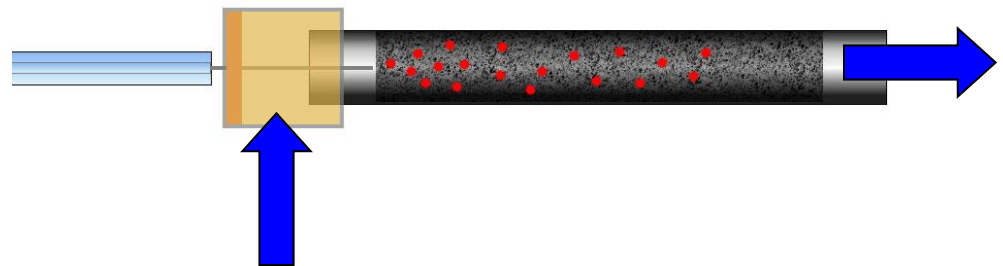

C-SLR injection of liquid standard in a flow of inert gas

From: Markes Technical Presentation

Standards used in this application

QC standard

Component	Amount injected	Ret.time
C7	0.32 µg abs.	2.95
C8	0.31 µg abs.	5.29
C9	0.34 µg abs.	7.59
C10	0.31 µg abs.	9.20
C11	0.30 µg abs.	10.47
C12	0.34 µg abs.	11.57
C13	0.34 µg abs.	12.56
C14	0.35 µg abs.	13.47
C16	0.36 µg abs.	15.14
Benzene	0.34 µg abs.	2.49
Toluene	0.35 µg abs.	4.30
o-Xylene	0.33 µg abs.	6.97
p-Xylene	0.35 µg abs.	7.43
2-Ethylhexanole	0.35 µg abs.	9.59
Diethyladipate	0.37 µg abs.	20.38

Calibration standard

Component	Conc.	Ret.time
Toluol	0.5 µg/µL	4.30
C16	0.5 µg/µL	15.14

2µL Std in MeOH are used

QC standard

RT: 1.50 - 21.10

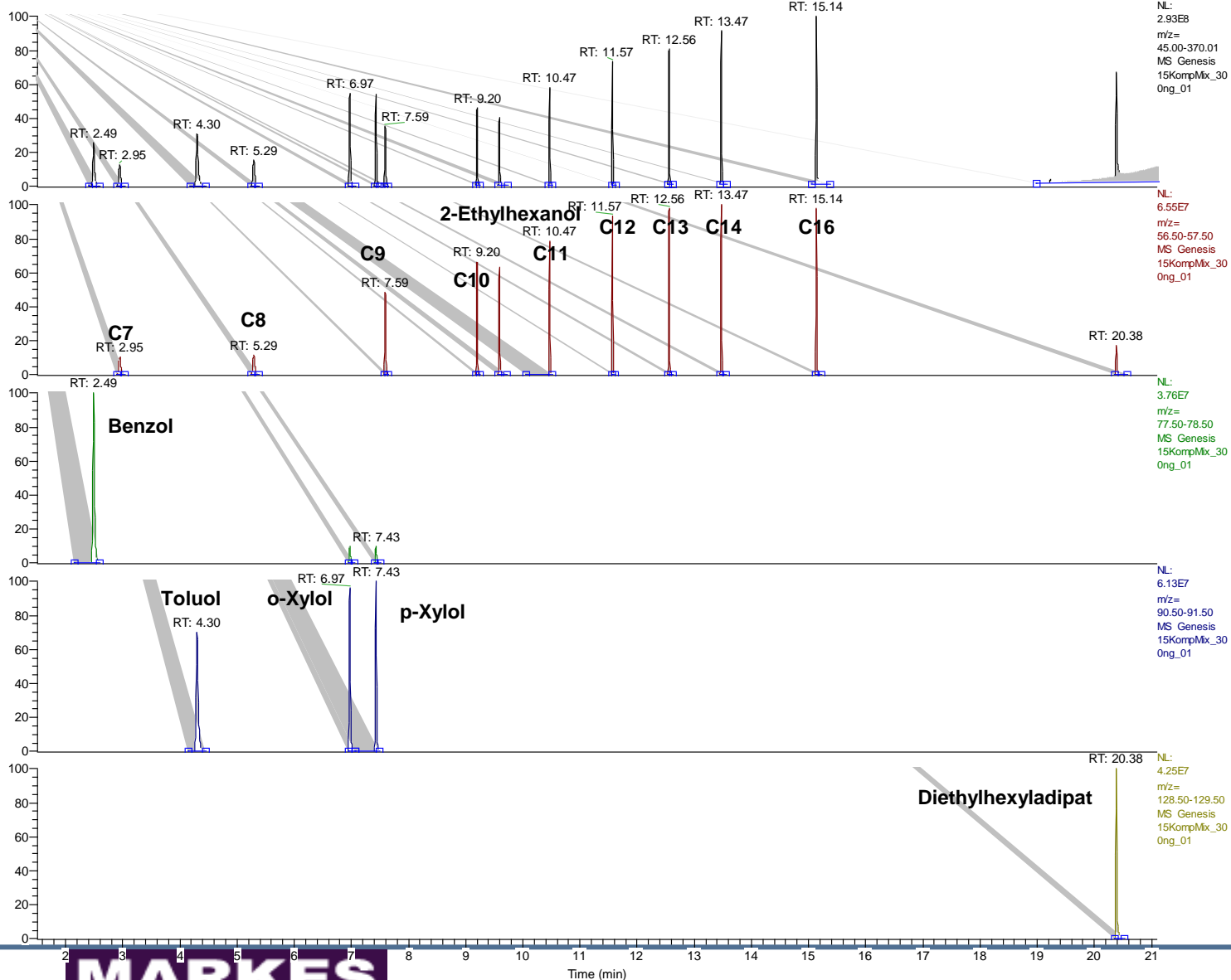

TIC

m/z=57

m/z=78

m/z=91

m/z=129

Calibration standard: Toluene + C16: 1 μ g each

c:\xcalibur...ltds files\std_mix_vda_01
Toluol+C16 je 1ug, Tube 142662

10/28/2010 9:38:24 AM

RT: 0.12 - 19.65

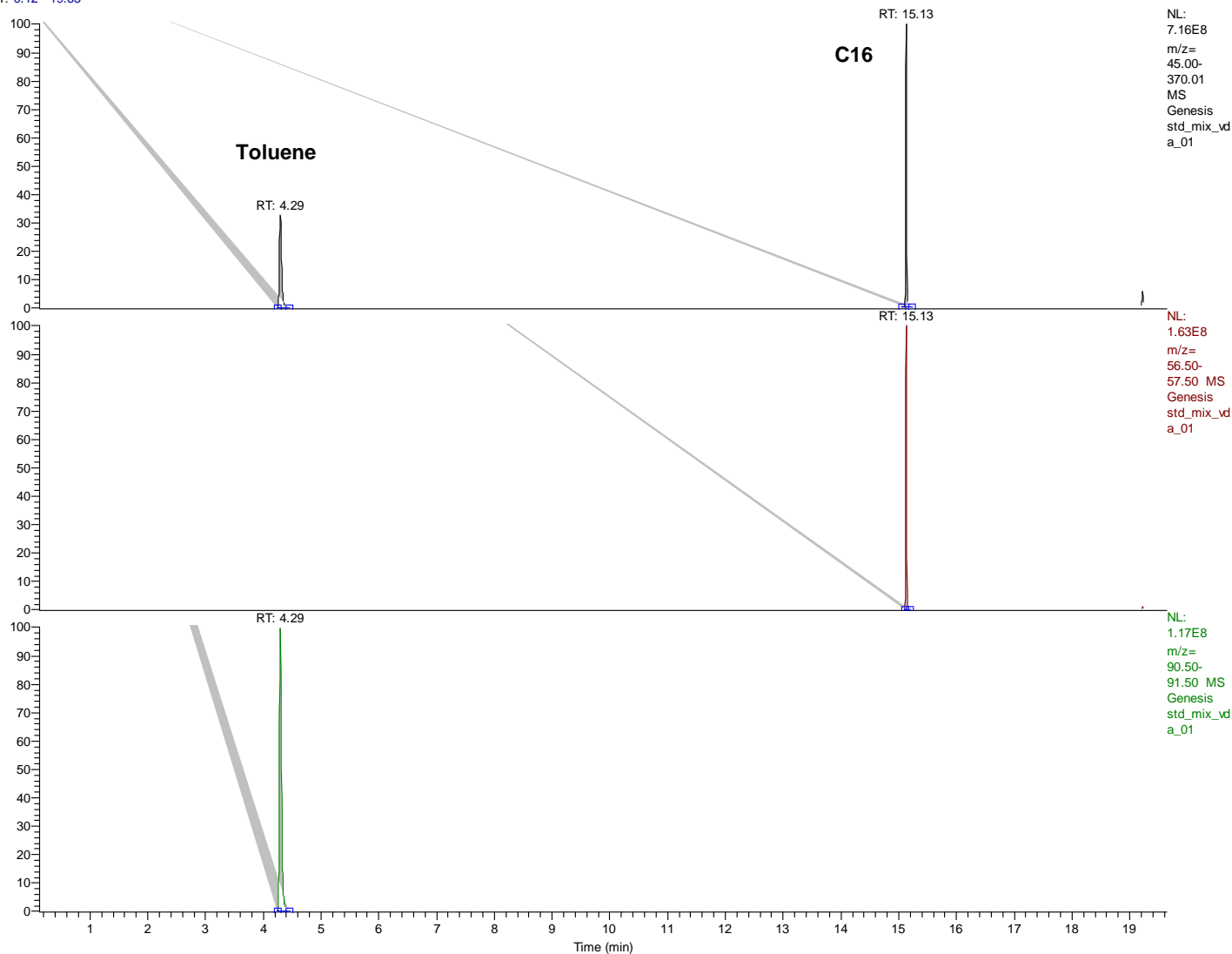

VOC analysis in a Leather sample

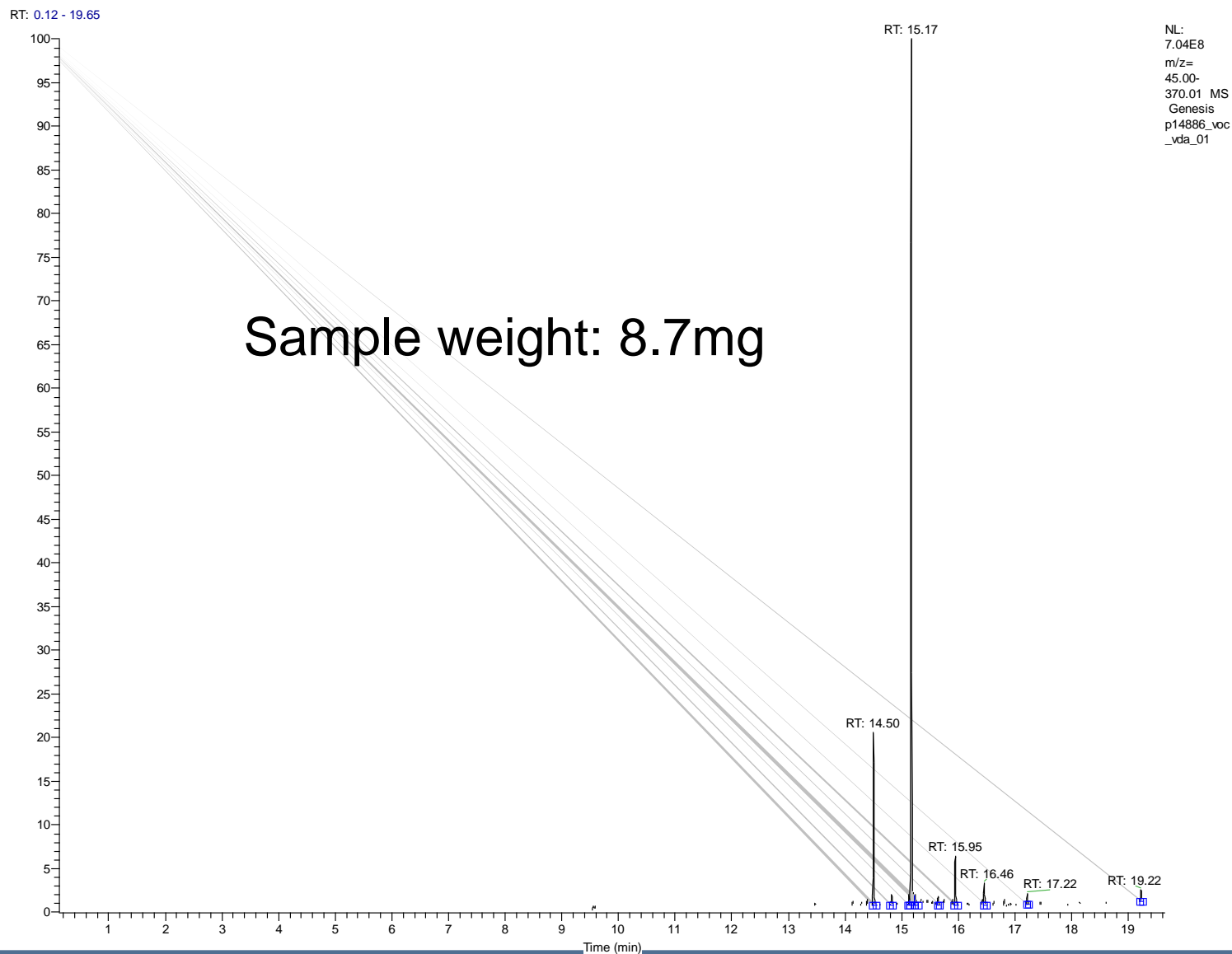

Quantitative calculation according to VDA278 using Excel

PEAK LIST

Calibration std 2µL

RT: 0.00 - 27.37

Number of detected peaks: 2

	Apex RT	Area	Smpl wt.	RF
Toluene	4.33	529551054	1.0 µg	0.00189
C16	15.16	493687204	1.0 µg	0.00203

PEAK LIST

Leather 1, 7.5mg

RT: 9.35 - 17.57

Number of detected peaks:

17

Apex RT	Area	Smpl wt.	Emission
0.31	3269790	7.5 µg	0.82 µg/g
1.4	6378870	7.5 µg	1.61 µg/g
1.42	5510904	7.5 µg	1.39 µg/g
9.57	3244823	7.5 µg	0.82 µg/g
12.8	2169023	7.5 µg	0.55 µg/g
14.32	3263013	7.5 µg	0.82 µg/g
14.54	50653977	7.5 µg	12.75 µg/g
14.86	3448186	7.5 µg	0.87 µg/g
15.2	197164983	7.5 µg	49.64 µg/g
15.27	5493497	7.5 µg	1.38 µg/g
15.68	4914860	7.5 µg	1.24 µg/g
15.74	2379247	7.5 µg	0.60 µg/g
15.98	6359969	7.5 µg	1.60 µg/g
16.49	3742545	7.5 µg	0.94 µg/g
16.84	4345190	7.5 µg	1.09 µg/g
19.26	18002683	7.5 µg	4.53 µg/g
19.84	2494424	7.5 µg	0.63 µg/g
Sum			81.3 µg/g

Leather sample according to VDA 278, Weight: 8.7mg

c:\xcalibur\...p14886_voc_vda_01
High Split, 8.7mg, Tube 159483

10/27/2010 7:47:32 PM

RT: 0.12 - 19.65

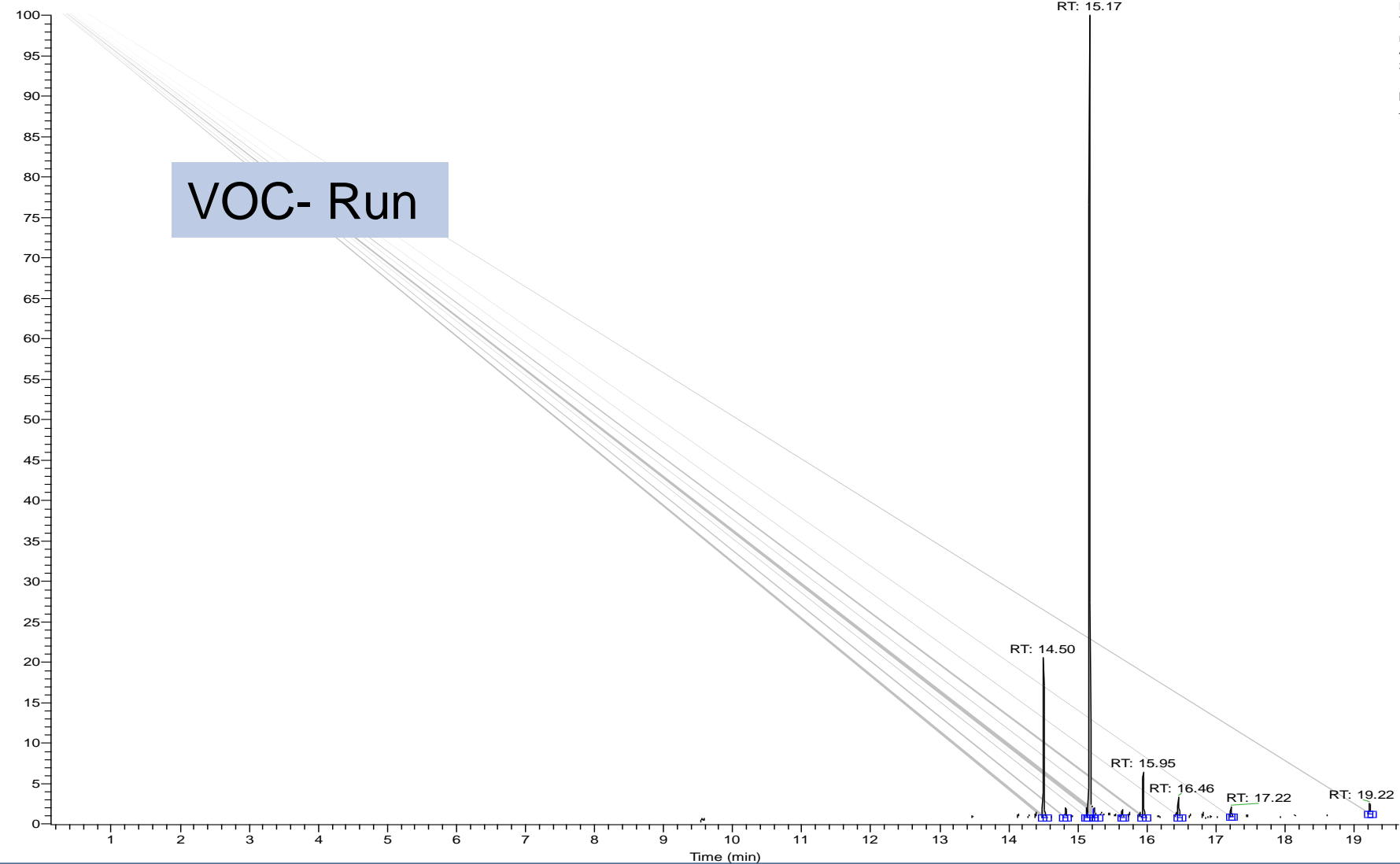

NL:
7.04E8
m/z=
45.00-
370.01 MS
Genesis
p14886_voc
_vda_01

Leather 1: Identification of main components

RT: 29.04 - 35.97

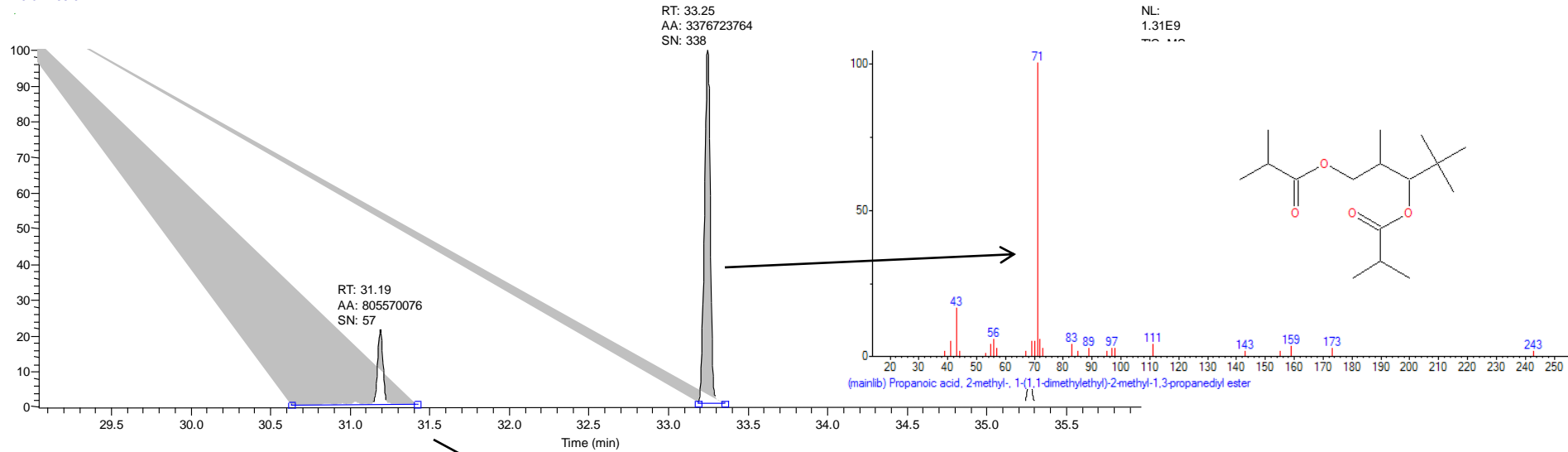

p14886_voc_vda_02 #9759-9768 RT: 33.22-33.25 AV: 10 NL: 3.73E8
T: (0,0) + c EI Full ms [29.00-370.00]

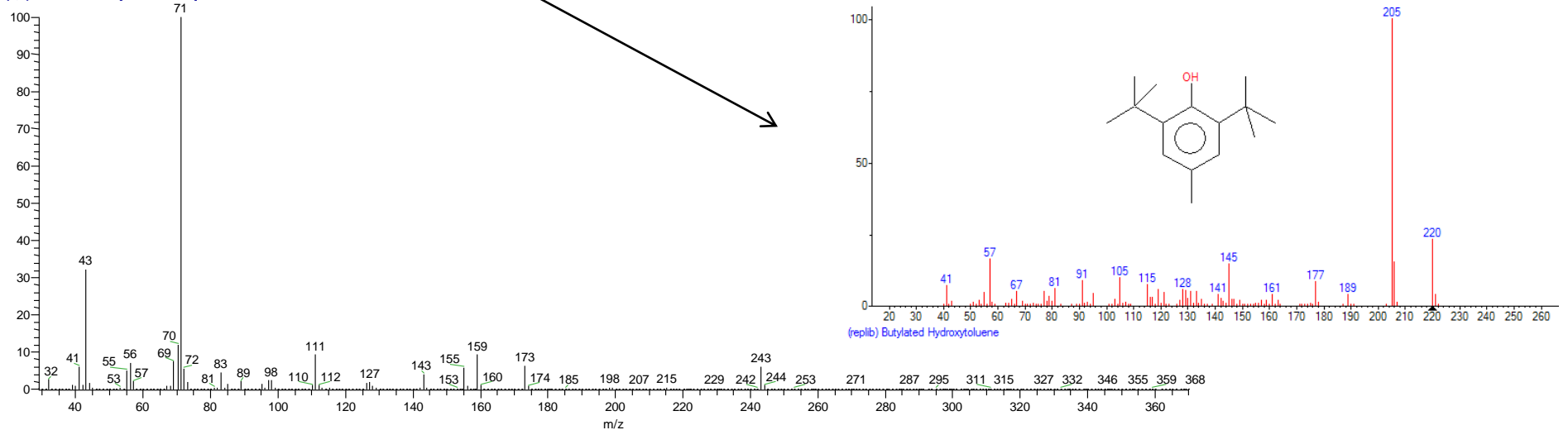

Leather sample according to VDA 278, Weight: 8.7mg

RT: 0.00 - 54.95

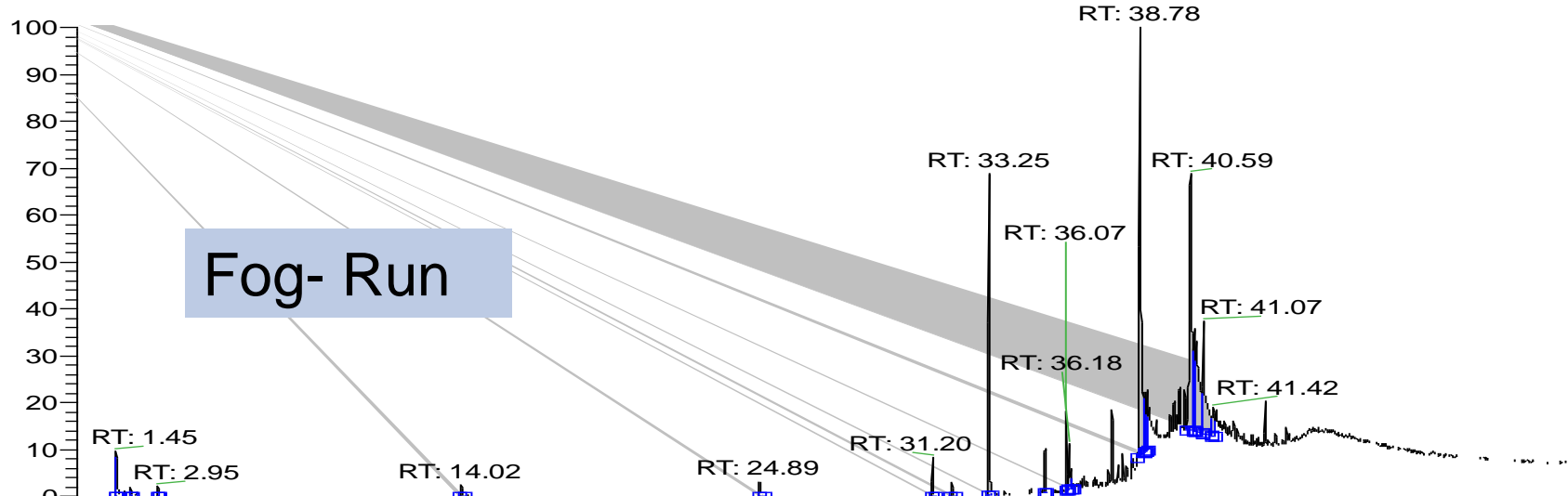

NL:
9.08E8
m/z=
45.0-370.0
MS
Genesis
P14886_FO
G_VDA_04

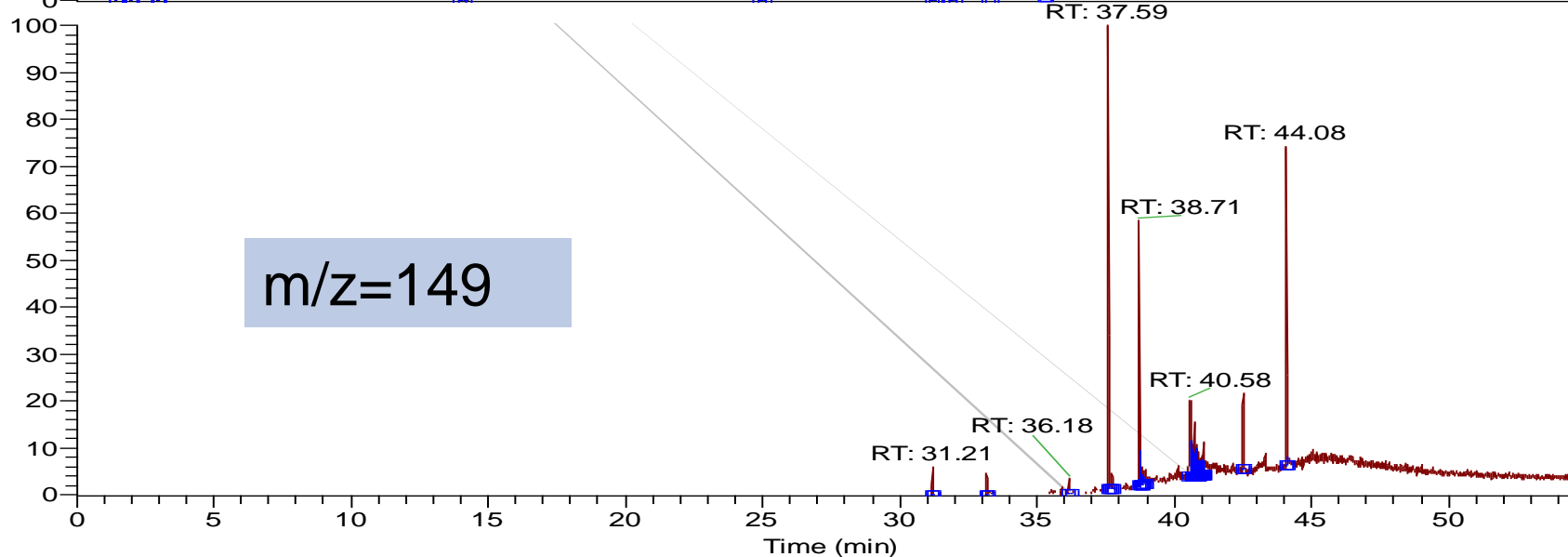

NL:
1.32E7
m/z=
148.5-
149.5 MS
Genesis
P14886_FO
G_VDA_04

PVC sample

RT: 0.00 - 43.65

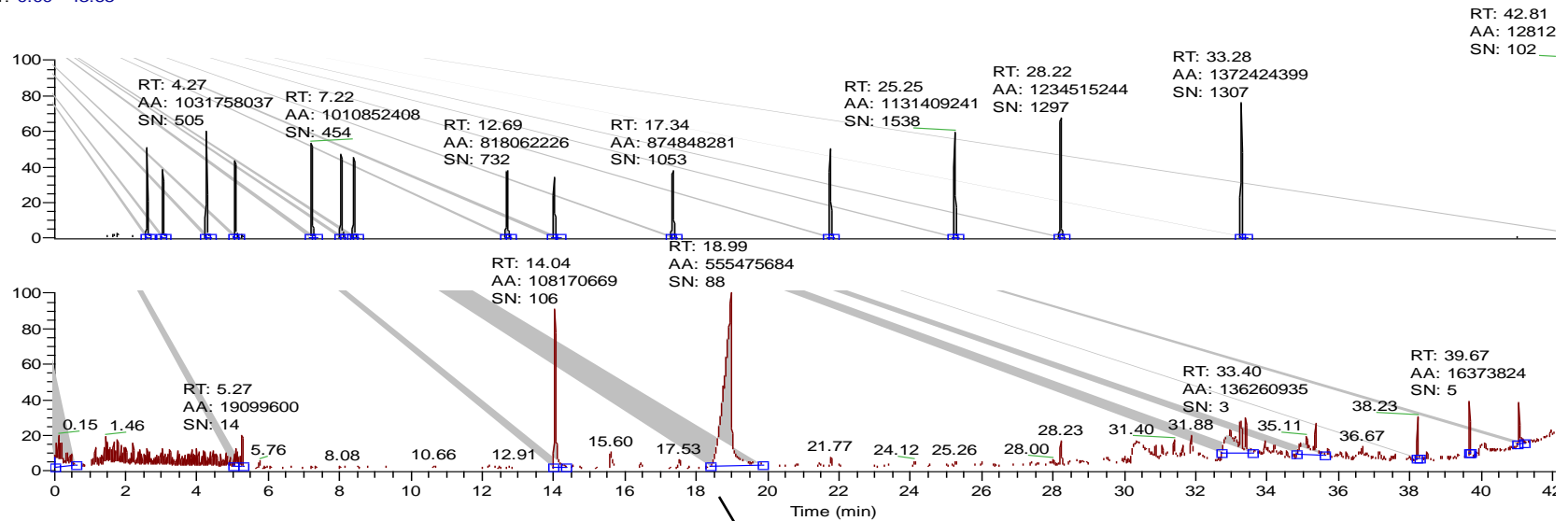

p15191_voc_vda_02 #5476-5542 RT: 18.65-18.88 AV: 67 SB: 131 19.62-20.06 NL: 3.60E5
T: (0,0) + c EI Full ms [29.00-370.00]

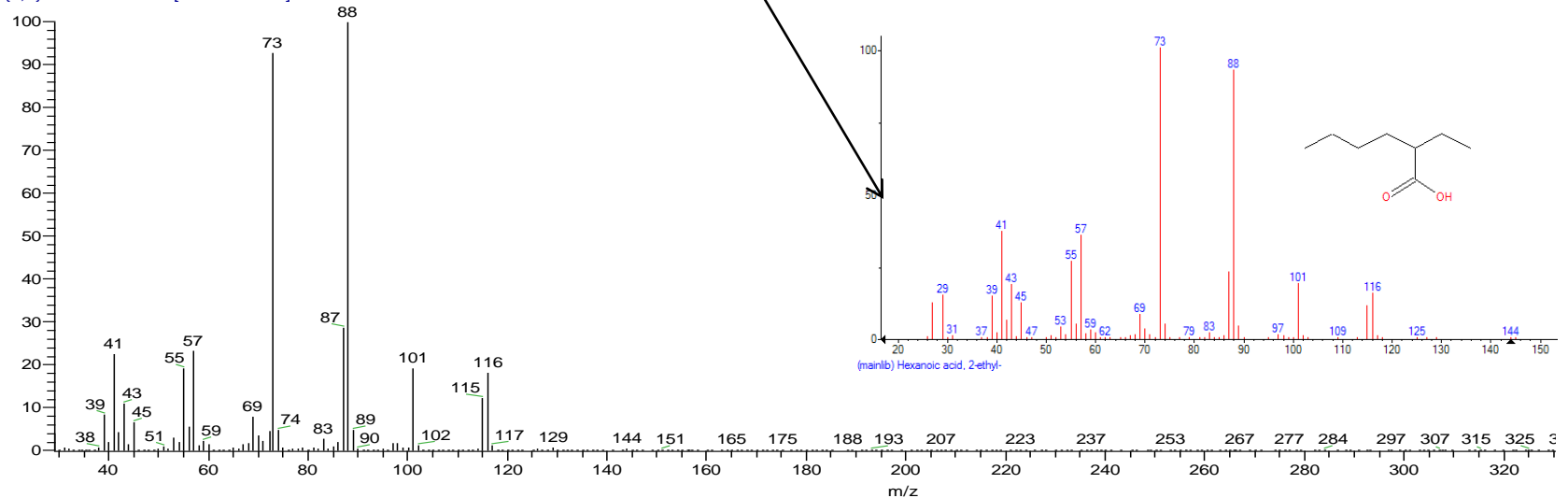

Artificial leather VOC

Artificial Leather

VOC Analysis

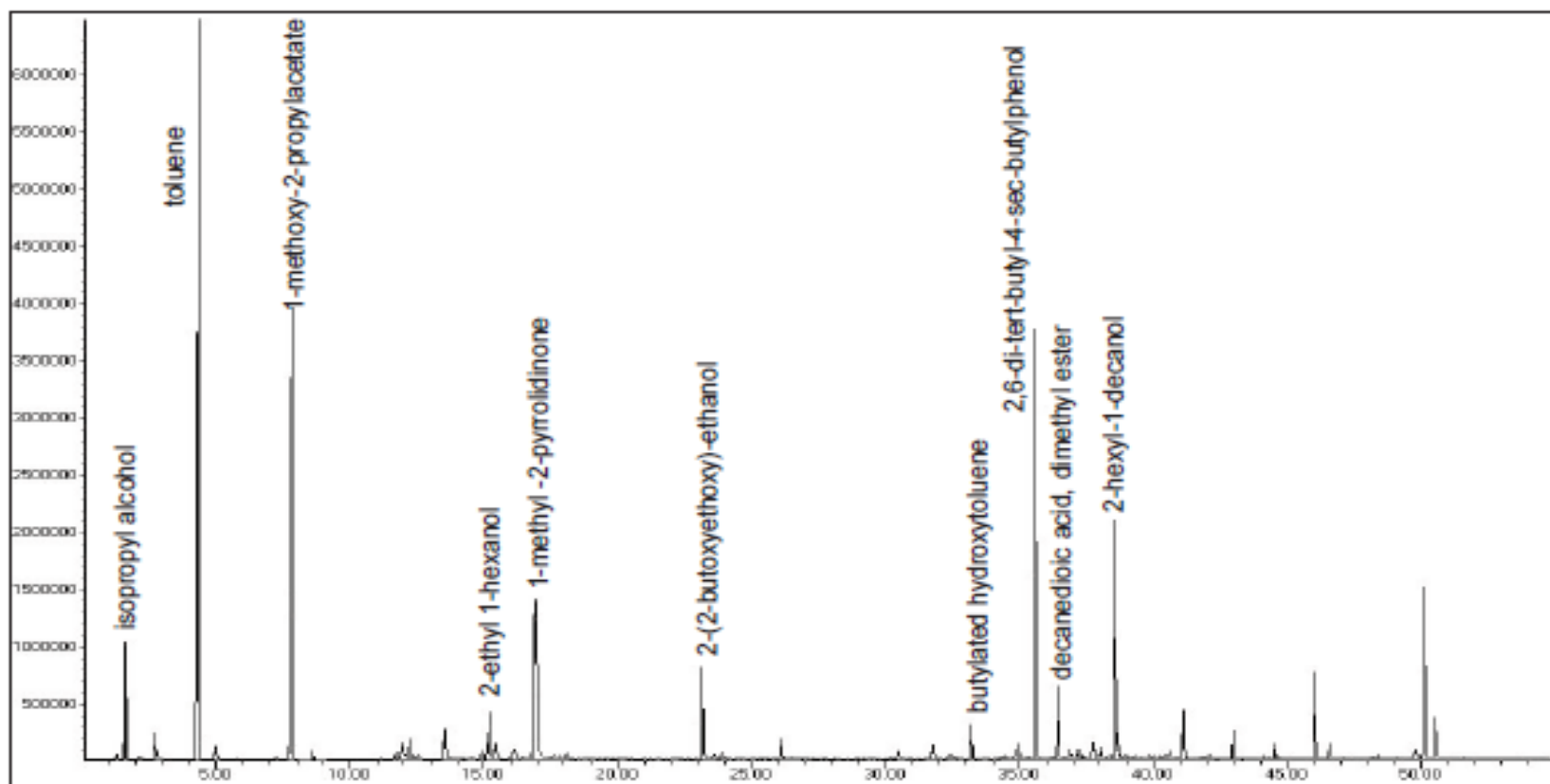

Figure 6. VOC analysis of artificial leather sample

Artificial leather FOG

FOG Analysis

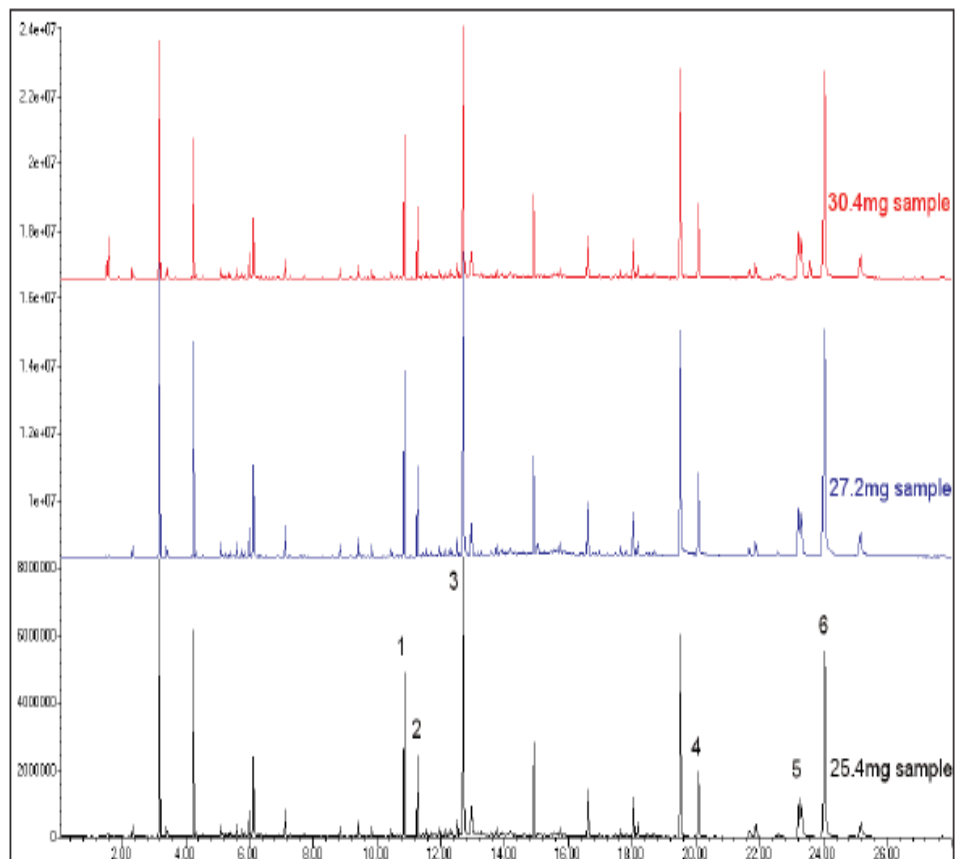

Figure 7. FOG analysis of 3 samples of artificial leather

Compound #	Name	Mean $\mu\text{g} / \text{g}$
1	2,6-di-tert-butyl-4-sec-butyl phenol	33.3 ± 3.1
2	decanedioic acid, dimethyl ester	16.8 ± 1.6
3	2-hexyl-1-decanol	73.7 ± 5.9
4	bis(1,2,2,6,6-pentamethyl-4-piperidiny) sebacate	24.9 ± 2.5
5	di-i-decyl phthalate	20.0 ± 2.3
6	di-n-decyl phthalate	116.9 ± 15.6

Conclusions

- Thermal desorption by Markes:
 - Reliable; every tube is leak tested
 - Controlable; repeat injections through recollection
 - Completely controlled by software
 - Enormously versatile
- GCMS by ThermoFisher :
 - High robustness
 - High productivity
 - High reliability
- A powerful combination providing complete thermal desorption GCMS solutions for your lab
- **info:** go to www.markes.com and get access to all the applications
- And www.thermo.com for more info on the ISQ and the applications

