

### Drug Analysis Using "Co-Sense for BA" LC/MS System (2)

"Co-Sense for BA" is a column-switching HPLC system that can automatically perform on-line pretreatment to remove proteins in biological fluids. The Shim-pack MAYI series pretreatment columns are silica-based restricted-access media columns. The outer surface of these columns is coated with a hydrophilic polymer. The inner surface has been chemically modified for analysis based on reversed-phase mode, cation-exchange mode, or anion-exchange mode. The mode can be selected in

accordance with the target constituents. An example of analysis performed in reversed-phase mode using the Shim-pack MAYI-ODS (G) was presented in "Application News No. C24". An example of the LC/MS analysis of a basic drug performed using Shim-pack MAYI-SCX (G), which is used for cation-exchange mode, is presented here. Refer to "Application News No. L327" for an example of the application of the Shim-pack MAYI-SCX (G) using an absorbance detector.

Analysis was performed on the tricyclic antidepressants doxepin, desipramine, imipramine, nortriptyline, amitriptyline, and clomipramine. Rat plasma spiked with these drugs were injected. Fig.1 shows the system configuration. Each sample was injected by the autosampler and sent to the pretreatment column. The drugs were trapped whereas the proteins were discharged. The flow line at valve A was switched so that the drugs were

introduced by the analytical mobile phase to the analytical column, where they were separated. While the drug substance was being eluted, the flow line was connected to the mass spectrometer using valve B. Fig.2 shows the SIM chromatograms obtained for each test compound at a concentration of 10 ng/mL. The protonated molecules in each of the constituents were used as monitor ions. High-sensitivity analysis was possible with minimized peak tailing.

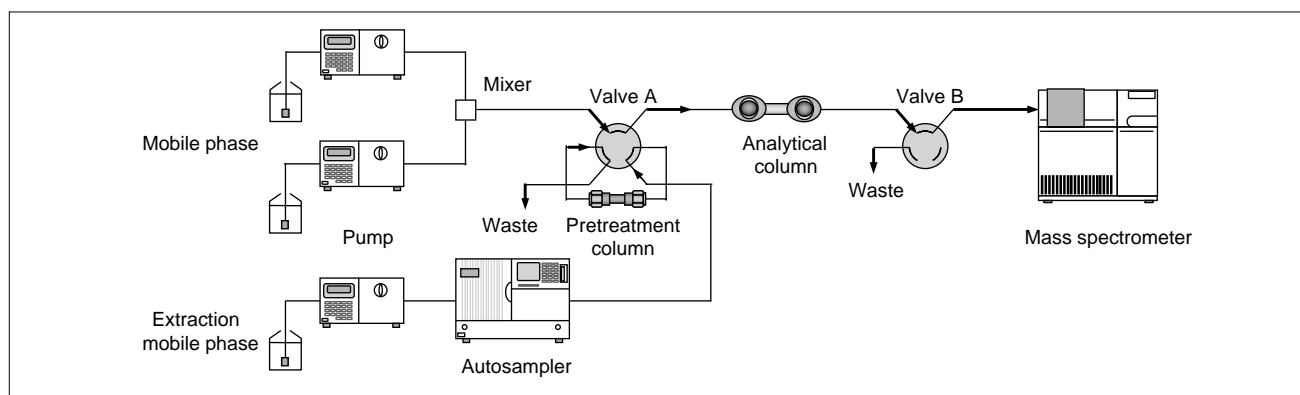

Fig.1 Flow Diagram of "Co-Sense for BA" LC/MS System

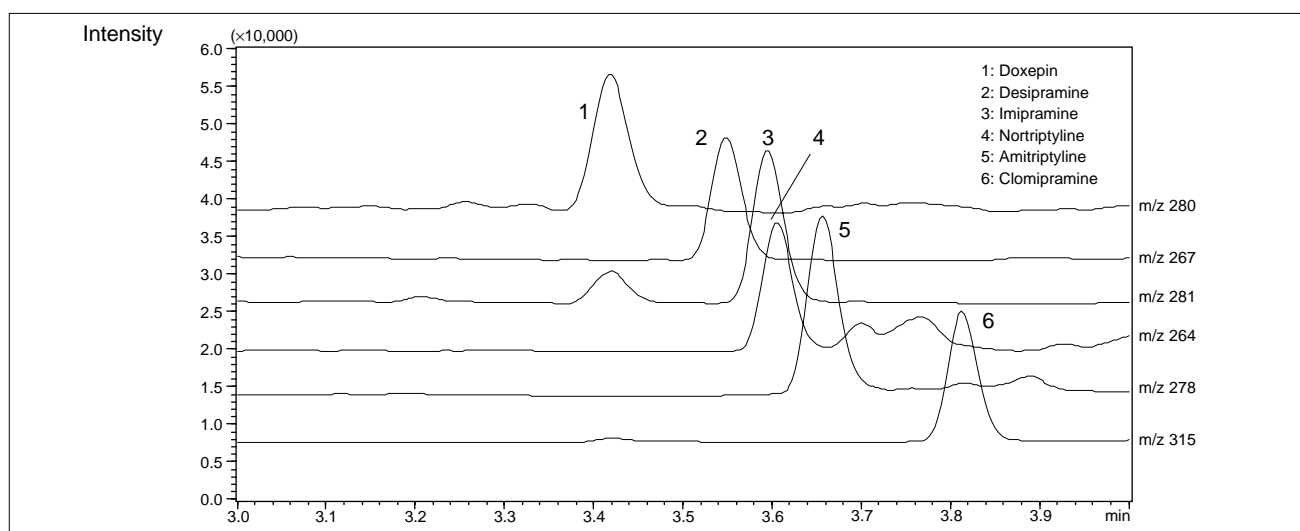

Fig.2 SIM Chromatograms of Test Compounds (10 ng/mL Each)

Fig.3 shows the first and 150th SIM chromatograms obtained by injecting 50 ng/mL of each constituent and performing consecutive 150 analysis. The RSD values of the peak areas for the constituents did not exceed

11 % and the RSD values of the retention times did not exceed 0.12 %. This indicates that deviation was minimal, and reliable measurement was possible.

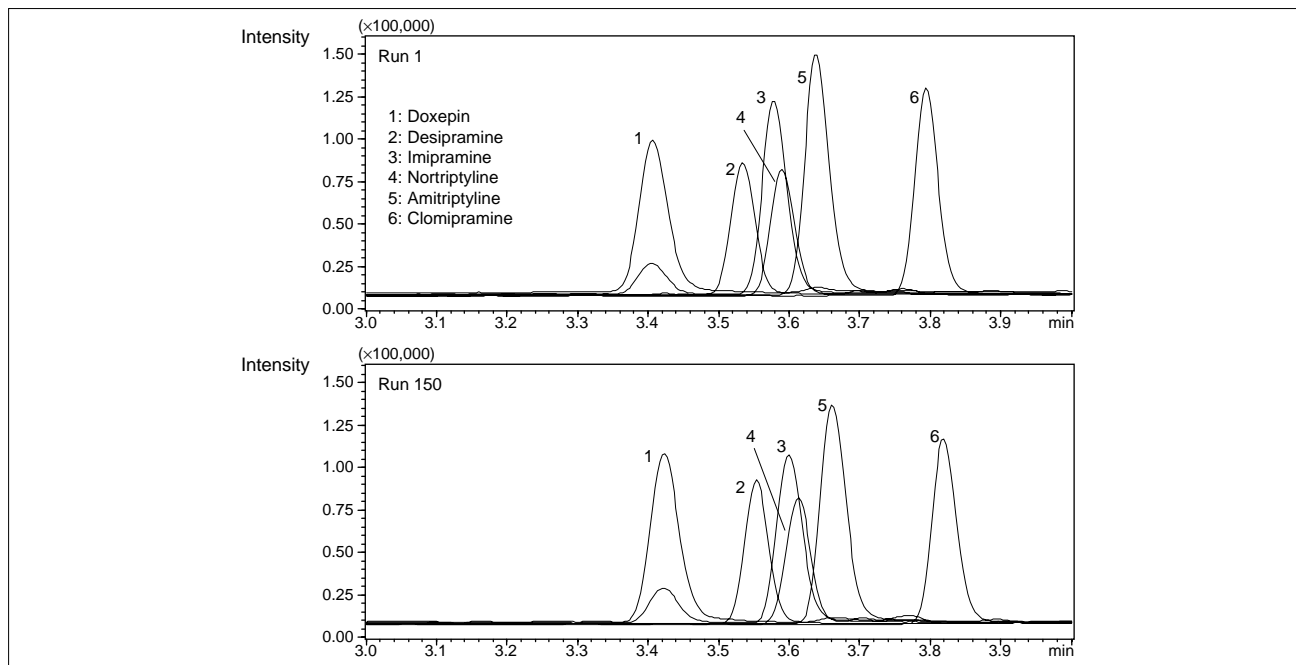

Fig.3 SIM Chromatograms of Repeat Injections (Top: 1st Run; Bottom: 150th Run; 50 ng/mL Each)

Table 1 Analytical Conditions

Pretreatment	
Column	: Shim-pack MAYI-SCX(G) (4.6 mm I.D. × 10 mmL.)
Mobile phase	: water containing 0.1 % acetic acid
Flow rate	: 3.0 mL/min
Column temperature	: 40 °C
Injection volume	: 20 µL
Pretreatment time	: 1.0 min
Analysis	
Column	: Phenomenex Gemini C18 (2.0 mm I.D. × 50 mmL., 5 µm) with a SecurityGuard C18 cartridge (2.0 mm I.D. × 4 mmL.)
Mobile phase A	: 100 mM ammonium acetate buffer (pH 5.0)
Mobile phase B	: acetonitrile
Time program	: 20 %B (0-1.0 min) → 90 %B (4.0 min) → 20 %B (4.01-7.0 min)
Flow rate	: 0.5 mL/min
Column temperature	: 40 °C
Valve B (to MS)	: 3.0-4.0 min
Probe voltage	: +4.5 kV (ESI-Positive mode)
Nebulizing gas flow	: 1.5 L/min
Drying gas pressure	: 0.2 MPa
CDL temperature	: 250 °C
Block heater temperature	: 200 °C
CDL, Q-array voltages	: using default values
SIM	: m/z 280 (doxepin), 267 (desipramine), 281 (imipramine), 264 (nortriptyline), 278 (amitriptyline), 315 (clomipramine)

\*The published data was not acquired using an instrument registered by Japanese pharmaceutical affairs law.

**NOTES:**

\*This Application News has been produced and edited using information that was available when the data was acquired for each article. This Application News is subject to revision without prior notice.



SHIMADZU CORPORATION. International Marketing Division

3. Kanda-Nishikicho 1-chome, Chiyoda-ku, Tokyo 101-8448, Japan Phone: 81(3)3219-5641 Fax: 81(3)3219-5710  
Cable Add.: SHIMADZU TOKYO