

Analysis of Gasoline Blends and Finished Gasoline using Reformulyzer[®] M4 – OPNA Mode

- **Fast Analysis in 39 minutes**
- **In compliance with key methods EN ISO 22854 and ASTM D6839**

Keywords:

Reformulyzer , Group-Type Analysis, OPNA



INTRODUCTION

With the introduction of the 4th generation AC Analytical Controls (AC) Reformulyzer M4, group type analysis of gasolines and its precursors & blend streams has become easier and much faster than before.

The Reformulyzer M4 benefits from the use of capillary/Micropacked columns and traps, resulting in unprecedented speed of analysis, the widest analytical range and excellent precision. It complies with key methods EN ISO 22854 and ASTM D6839 and derived methods.

Depending on the sample stream or product, a range of analytical modes can be used, ensuring shortest possible runtimes, and data as required for that specific product. See Table 1.

This application note describes the quantitative determination of hydrocarbon types and oxygenates in Gasoline Blends and Finished Gasolines using the AC Reformulyzer M4.

Typical Modes Used:	PNA	OPNA	PIPNA	PONA	PIONA	PIANO	OPIONA	GASOLINE	FAST GROUP TYPE	E85
Light Straight Run Naphtha	X		X			X				
Heavy Straight Run Naphtha	X		X			X				
Depentanized Bottom Reformate	X		X			X				
FCC Light/Med/Heavy				X	X					
Visbreaker				X	X					
Alkylate / Isomerate			X							
Gasoline Blend							X	X	X	
Gasoline w. Oxygenates		X					X	X		
E85, E20										X
Analysis Time	25	30	30	30	55	40	60	39	15	39

Table 1: Reformulyzer M4 Analysis Modes vs Product Streams

INSTRUMENTAL

The determination of different hydrocarbon types and oxygenates is achieved by separation and elution on a series of designed traps and columns. The flow diagram for Reformulyzer M4 is shown below in Figure 1, and the analysis schedule used for this specific method is in Table 2. The Polar Column separates the Paraffins and Naphthenes from the Aromatics while Heavy Aromatics and Alcohols are retained on the Pre-Column. Ethers pass unretained and are trapped on the Ether/Alcohol-trap to be analyzed on the Boiling Point column. Further separation of Saturates is on the 13X Column resulting in a carbon number distribution.

By using multiple valves and columns the Aromatics, PolyNaphthenes and Alcohols are analyzed on a Boiling Point Column in two different Aromatic fractions.

The Micropacked traps and columns are located in the left side and have separate heater elements for individual temperature programming. This allows heating and/or cooling of traps simultaneous, resulting in total analysis runtime of 30 minutes.

From (min)	To (min)	Components	Column route
0	12	C4 to C11 N+P	1 st Polar column fraction on 13X Column
12	14.5	Ethers	Trapped Ethers via E/A-trap to Boiling Point Column
14.5	16	> 185°C	Backflush Boiling Point Column
16	20	C6 to C8 A and pN	2 nd Polar Column fraction via E/A-trap to Boiling Point Column
20	22	> 185°C	Backflush Boiling Point Column of 2 nd Polar Column fraction
22	28	Alcohols + C8 to C10 A	3 rd Polar Column fraction via E/A-trap to Boiling Point Column
28	30	> 185°C	Backflush Boiling Point Column of 3 rd Polar Column fraction

Table 2: Reformulyzer M4 OPNA method

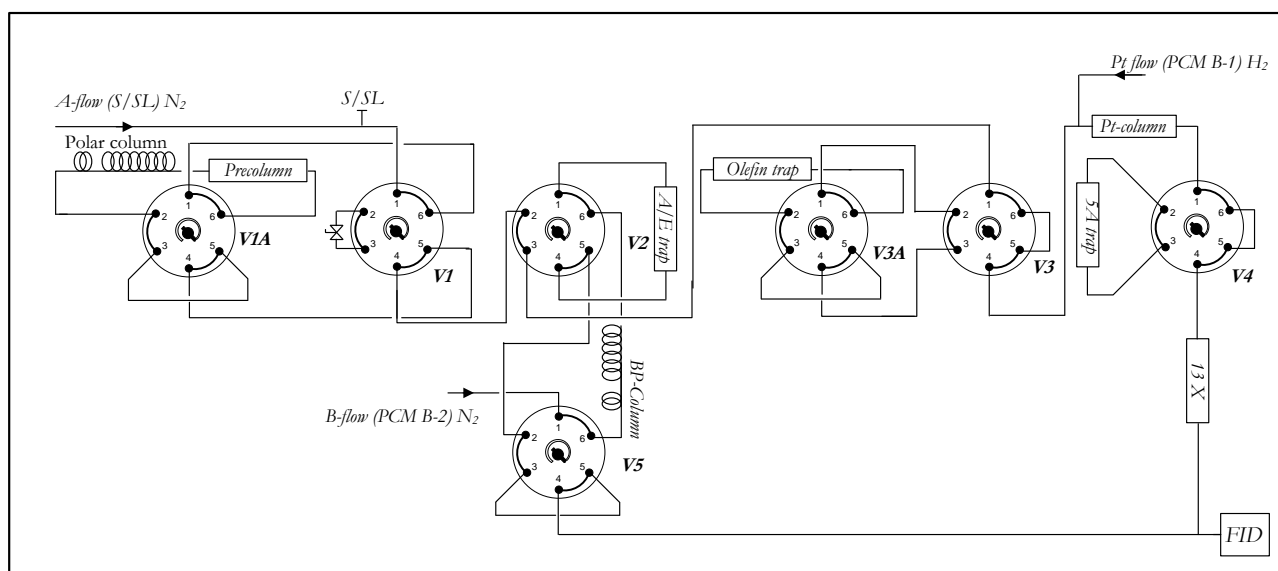

Figure 1: Reformulyzer M4 Flow Diagram

Gravimetric Blends and a Gasoline K Certified Reference Materials (CRM) were analyzed using the Reformulyzer M4 in OPNA mode. Representative chromatograms are shown below and typical report outputs from the analysis for the CRM are in Tables 3 and 4.

Chromatograms show clear group separations for Paraffins, Naphthenes, Aromatics and Oxygenates, and %Weight and %Volume by carbon numbers are well within specifications for this particular CRM.

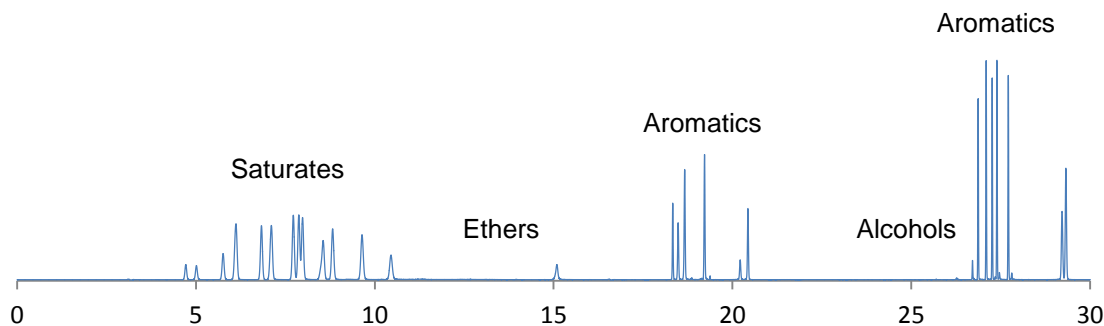

Figure 2: Reference Sample Gravimetric Blend (50.16.512) in OPNA mode

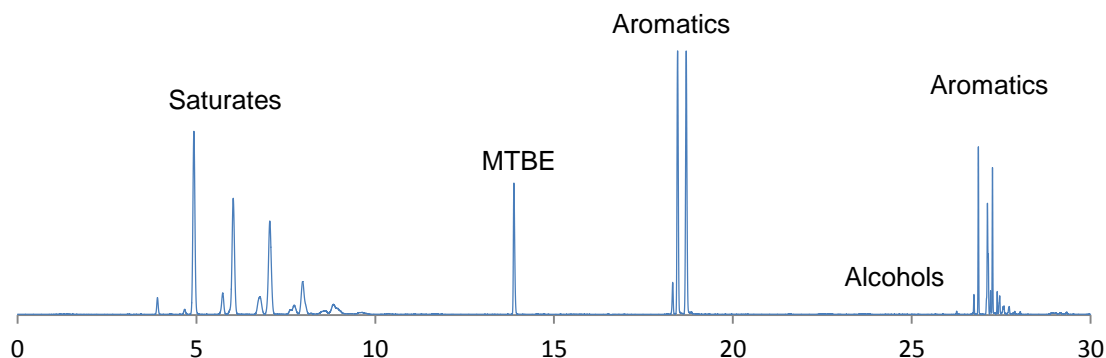

Figure 3: Gasoline K CRM (00.02.045) in OPNA mode

Normalized weight percent results

Cnr	Naph.	Paraf.	Arom.	Oxyg.	Total
2					
3					
4		0.93			0.93
5	0.32	14.31		9.85	24.48
6	1.73	11.09	1.16		13.98
7	2.47	10.11	11.58		24.16
8	1.41	4.11	16.74		22.26
9	0.70	2.21	9.30		12.21
10		0.38	1.08		1.46
11+			0.42		0.42
Poly	0.11				0.11
Total	6.74	43.14	40.28	9.85	100.00

Table 3: Reporting Gasoline K Weight%

Normalized volume percent results

Cnr	Naph.	Paraf.	Arom.	Oxyg.	Total
2					
3					
4		1.21			1.21
5	0.32	17.15		9.86	27.33
6	1.71	12.57	0.99		15.27
7	2.43	11.02	9.98		23.43
8	1.36	4.36	14.42		20.14
9	0.66	2.28	7.96		10.90
10		0.39	0.90		1.29
11+			0.35		0.35
Poly	0.09				0.09
Total	6.57	48.98	34.60	9.86	100.00

Table 4: Reporting Gasoline K Volume%

CONCLUSION

The Reformulyzer M4 provides reports group type data in full accordance with key methods EN ISO 22854 and ASTM D6839.

Weight% and Volume% profile reports are generated grouping naphthenes, paraffins, aromatics and oxygenates by carbon number as well as the totals of the different groups and the totals by carbon number.

Through the use of Capillary and Micropacked columns and Traps The Reformulyzer M4 takes only 30 minutes to produce reliable results in OPNA mode.

Specifications

Scope / Separation Range	Finished gasoline Reformer feed Reformate Straight naphtha FCC naphtha/Olefins Isomerates Alkylate E10+/E85	Paraffins C4-C11 Isoparaffins C4-C11 Olefins C4-C11 Naphthenes C5-C11 Aromatics C6-C11 Oxygenates C1-C6 (includes Methanol, Ethanol, n-Propanol, i-Propanol, t-Butanol, i-Butanol, 2-Butanol, tert-amylalcohol, MTBE, ETBE, DIPE, TAME)
--------------------------	--	--

Method Compliance

According Methods ASTM D6839, EN-ISO22854, ASTM D5443, IP566, SH/T 0741, GB/T 28768-2012

Ordering Information

CCG3500A	Reformulyzer M4 110V
CCG3500B	Reformulyzer M4 200V
CCG3500C	Reformulyzer M4 230V

Table 5: Reformulyzer M4 Specifications & Ordering Information

AC Analytical Controls® has been the recognized leader in chromatography analyzers for gas, naphtha and gasoline streams in crude oil refining since 1981. AC also provides technology for residuals analysis for the hydrocarbon processing industry. Applications cover the entire spectrum of petroleum, petrochemical and refinery, gas and natural gas analysis; ACs Turn-Key Application solutions include the AC Reformulyzer®, SimDis, Hi-Speed RGA and Customized instruments.